



Heating and Air Conditioning

## TECHNICAL GUIDE

### SINGLE PACKAGE GAS/ELECTRIC UNITS AND SINGLE PACKAGE AIR CONDITIONERS

DH 180, 210, 240 & 300

15, 17.5, 20 & 25 NOMINAL TONS

10.8 EER (15 TONS), 10.2 EER (17.5 TONS), 9.7 EER (20 TONS) AND 9.6 EER (25 TONS)

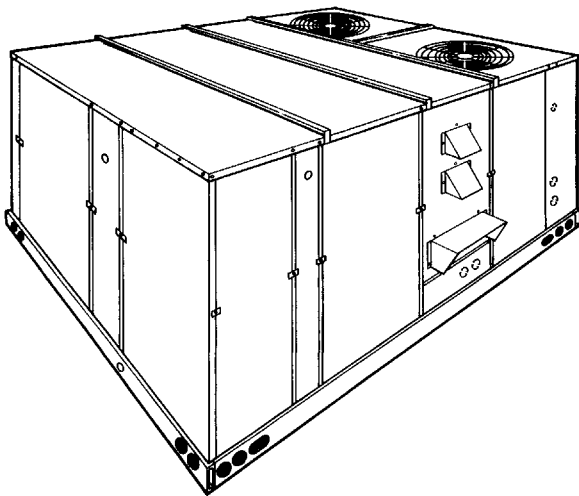

### DESCRIPTION

YORK Sunline Ultra™ units are convertible single package high efficiency rooftops. All models have independent dual refrigerant circuits for efficient part load operation. Although the units are primarily designed for curb mounting on a roof, they can also be slab-mounted at ground level or set on steel beams above a finished roof.

All units include:

- Powder Paint finish that meets ASTM-B-117 1000 hour salt spray standards
- Two-stage cooling provided by dual independent refrigeration circuits with expansion valves, filter-driers, high and low pressure/loss of charge switches and freezestats
- Hermetically sealed scroll compressors with crankcase heaters
- Two-stage heating provided by dual independent heat exchangers with aluminized steel tubes, redundant gas valves, spark ignition with induced draft logic
- Permanently lubricated motors
- Bottom or side air discharge configuration capability (field convertible)
- Belt Drive Blower Motor with high static drive options
- Constant supply air volume (CV) with optional variable air volume (VAV)
- Manufactured under the quality standards of ISO9001
- Twenty-four volt control circuit with compressor lock-out
- Zero-25% fixed air damper with hood
- Copper tube/aluminum fin coils
- Hinged filter access and tool free latched doors
- Hinged tool free blower, blower motor, filters and electrical panel access
- Rigging holes in base rails for lifting
- Single point power connection
- Complete factory package - tested, charged and wired
- CSA agency approvals on all units

### WARRANTY

- Factory Limited Parts Warranty
- One-year parts warranty
- A Five-year parts warranty on the compressor and electric heat elements.
- Ten-year parts warranty on the gas-fired heat exchangers.



TABLE OF CONTENTS

DESCRIPTION . . . . . 1
PRODUCT NOMENCLATURE . . . . . 3
FEATURES . . . . . 4
FACTORY-INSTALLED OPTIONS . . . . . 5
FIELD-INSTALLED ACCESSORIES . . . . . 8
GUIDE SPECIFICATIONS . . . . . 41

LIST OF FIGURES

Fig. # Pg. #
1 UNIT CUTAWAY . . . . . 5
2 ALTITUDE/TEMPERATURE CONVERSION FACTOR . . . . . 19
3 TYPICAL DH FIELD WIRING DIAGRAM . . . . . 32
4 UNIT DIMENSIONS DH180, 210, 240 & 300 (FRONT VIEW) . . . . . 34
5 REAR VIEW DIMENSIONS . . . . . 35
6 UNIT DIMENSIONS DH180, 210, 240 & 300 (RAINHOOD) . . . . . 36
7 UNIT CENTER OF GRAVITY . . . . . 37
8 TYPICAL UNIT APPLICATIONS . . . . . 37
9 UNIT 4 POINT LOAD . . . . . 38
10 UNIT 6 POINT LOAD . . . . . 38
11 UNIT ROOF CURB DIMENSIONS . . . . . 39
12 ROOF CURB DUCT OPENINGS DIMENSIONS . . . . . 39
13 CUT AWAY OF ROOF CURB . . . . . 39
14 TYPICAL ROOFTOP INSTALLATION . . . . . 40
15 TYPICAL SIMPLICITY® CONTROL WIRING DIAGRAM . . . . . 40

LIST OF TABLES

Tbl. # Pg. #
1 INDOOR SOUND POWER RATING . . . . . 9
2 CAPACITY RATINGS - (ARI 360) . . . . . 9
3 GAS HEAT RATINGS . . . . . 9
4 DH 180 COOLING CAPACITIES (15 TON) . . . . . 10
5 DH 210 COOLING CAPACITIES (17.5 TON) . . . . . 12
6 DH 240 COOLING CAPACITIES (20 TON) . . . . . 14
7 DH 300 COOLING CAPACITIES (25 TON) . . . . . 16
8 ALTITUDE CORRECTION FACTORS . . . . . 18
9 SUPPLY AIR BLOWER PERFORMANCE (15 TON) - COOLING ONLY 180 MBH - BOTTOM DUCT CONNECTIONS . . . . . 20

Tbl. # Pg. #
10 SUPPLY AIR BLOWER PERFORMANCE (17.5 TON) - COOLING ONLY 210 MBH - BOTTOM DUCT CONNECTIONS . . . . . 21
11 SUPPLY AIR BLOWER PERFORMANCE (20 TON) - COOLING ONLY 240 MBH - BOTTOM DUCT CONNECTIONS . . . . . 22
12 SUPPLY AIR BLOWER PERFORMANCE (15 TON) - GAS HEAT 180 MBH - BOTTOM DUCT CONNECTIONS . . . . . 23
13 SUPPLY AIR BLOWER PERFORMANCE (17.5 TON) - GAS HEAT 210 MBH - BOTTOM DUCT CONNECTIONS . . . . . 24
14 SUPPLY AIR BLOWER PERFORMANCE (20 TON) - GAS HEAT 240 MBH - BOTTOM DUCT CONNECTIONS . . . . . 25
15 SUPPLY AIR BLOWER PERFORMANCE (25 TON) - GAS HEAT 300 MBH - BOTTOM DUCT CONNECTIONS . . . . . 26
16 BLOWER MOTOR AND DRIVE DATA . . . . . 27
17 STATIC RESISTANCES . . . . . 27
18 POWER EXHAUST PERFORMANCE . . . . . 27
19 DH 180, 210 & 240 ELECTRICAL DATA WITHOUT POWERED CONVENIENCE OUTLET . . . . . 28
20 DH 300 ELECTRICAL DATA STANDARD MOTOR WITHOUT POWERED CONVENIENCE OUTLET . . . . . 29
21 DH 300 ELECTRICAL DATA HIGH STATIC MOTOR WITHOUT POWERED CONVENIENCE OUTLET . . . . . 29
22 DH 180, 210 & 240 ELECTRICAL DATA WITH POWERED CONVENIENCE OUTLET . . . . . 30
23 DH 300 ELECTRICAL DATA STANDARD MOTOR WITH POWERED CONVENIENCE OUTLET . . . . . 31
24 DH 300 ELECTRICAL DATA HIGH STATIC MOTOR WITH POWERED CONVENIENCE OUTLET . . . . . 31
25 DH VOLTAGE LIMITATIONS . . . . . 32
26 ELECTRIC HEAT CORRECTION FACTORS . . . . . 32
27 PHYSICAL DATA . . . . . 33
28 OPERATING WEIGHTS (LBS.) . . . . . 33
29 SUPPLY FAN VFD WEIGHTS, IN LBS. . . . . 33
30 UTILITIES ENTRY DATA . . . . . 34
31 MINIMUM CLEARANCES . . . . . 36
32 DH 180, 210, 240 & 300 4 POINT LOAD WEIGHT DISTRIBUTION . . . . . 38
33 DH 180, 210, 240 & 300 6 POINT LOAD WEIGHT DISTRIBUTION . . . . . 38

# PRODUCT NOMENCLATURE

## 15-25 Ton Sunline Ultra™ Model Number Nomenclature

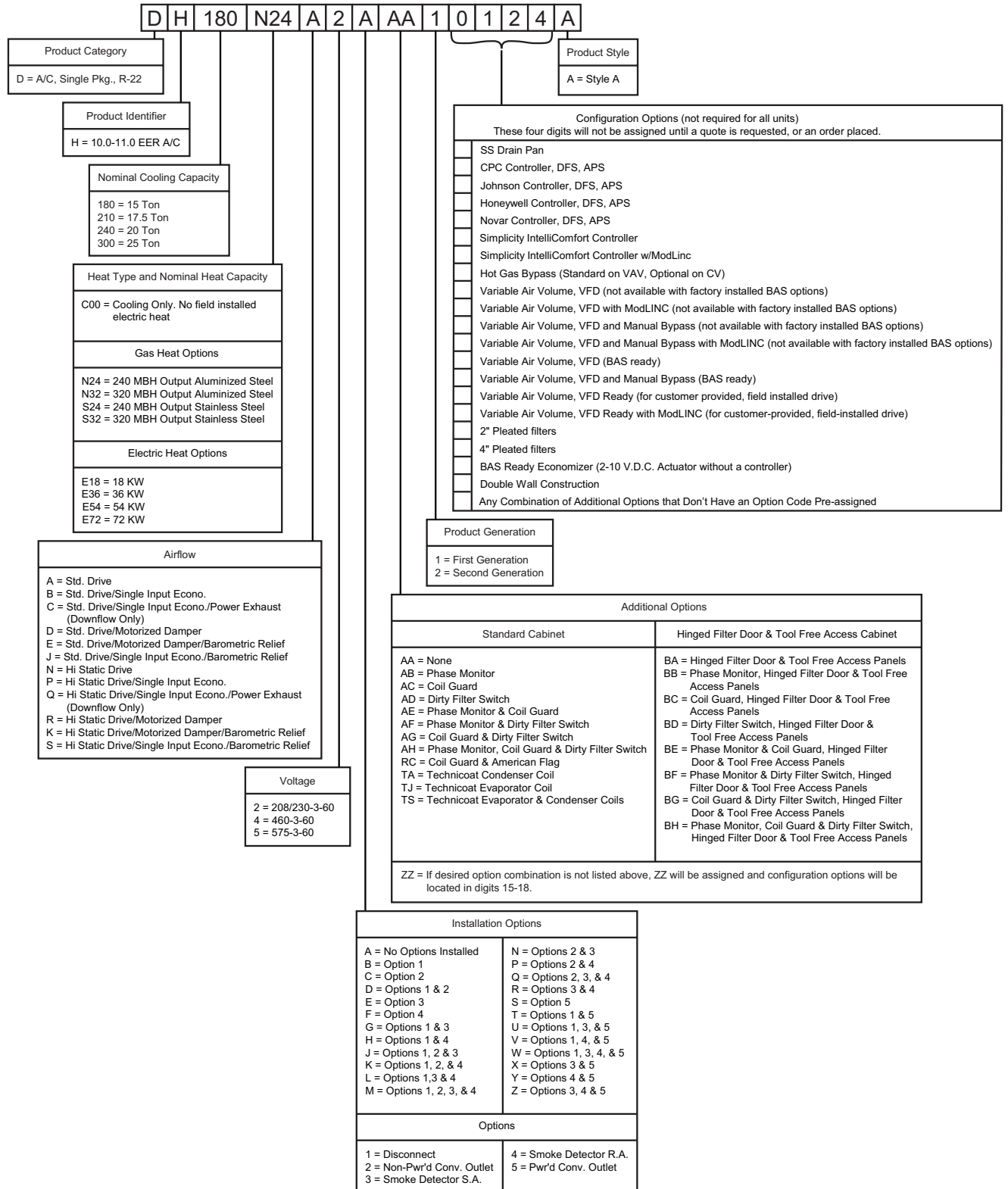

## FEATURES

All models are available with a wide variety of factory-mounted options such as stainless steel heat exchangers, phase monitor, dirty filter switch, and coil guard to make them suitable for almost every application.

All units are self-contained and assembled on full perimeter base rails with holes in the four corners for overhead rigging. Every unit is completely piped, wired, charged and tested at the factory to simplify the field installation and to provide years of dependable operation.

All models (including those with an economizer) are suitable for either bottom or horizontal duct connections. **Models with factory installed power exhaust are suitable for bottom duct connections only.** For bottom duct, you remove the sheet metal panels from the supply and return air openings through the base of the unit. For horizontal duct, you replace the supply and return air panels on the rear of the unit with a side duct flange accessory.

All models are available with these “factory mounted” outdoor air damper options:

- Single enthalpy economizer with or without power exhaust
- BAS-ready economizer with or without power exhaust
- Motorized outdoor air damper
- Barometric Relief Damper

A fixed outdoor air intake assembly will be shipped in the return air compartment of all units ordered without an economizer or motorized outdoor air damper option. The assembly includes a rain hood with a damper that can be set for 10, 15 or 25% outdoor air. With bottom duct connections, the intake damper assembly should be mounted over the opening in the return air panel. With horizontal ductwork, it should be mounted on the return air duct.

All supply air blowers are equipped with a belt drive that can be adjusted to meet the exact requirements of the job. A high static drive option is available for applications with a higher CFM and/or static pressure requirement. A variable air volume (VAV) option using a variable frequency drive is available for applications requiring a constant supply duct pressure. A differential pressure transducer is used to monitor supply duct static pressure and return a speed reference signal to the VFD to control the output of the indoor blower motor.

All compressors include scroll compressors and internal pressure relief. Every refrigerant circuit includes an expansion valve, a liquid line filter-drier, a discharge line high pressure switch and a suction line with a freeze-stat and low pressure/loss of charge switch to protect all system components. A hot gas bypass option, consisting of an adjustable compressor discharge bypass valve, is available for low cooling load applications.

- **Simplicity® Controls** - Simplicity® control boards have standardized a number of features previously available only as options or by utilizing additional controls.

- **Low Ambient** - An integrated low-ambient control allows all units to operate in the cooling mode down to 0°F outdoor ambient without additional assistance. Optionally, the control board can be programmed to lockout the compressors when the outdoor air temperature is low or when free cooling is available.
- **Anti-Short Cycle Protection** - To aid compressor life, an anti-short cycle delay is incorporated into the standard controls. Compressor reliability is further ensured by programmable minimum run times. For testing, the anti short cycle delay can be temporarily overridden with the push of a button.
- **Lead-Lag** - An integrated Lead-Lag option allows equal run time hours on all compressors, thereby extending the life of all compressors. This option is selectable on the unit control board.
- **Fan Delays** - Fan on and fan off delays are fully programmable. Furthermore, the heating and cooling fan delay times are independent of one another. All units are programmed with default values based upon their configuration of cooling and heat.
- **Safety Monitoring** - The control board monitors the high and low-pressure switches, the freeze-stats, the gas valve, if applicable, and the temperature limit switch on gas and electric heat units. The unit control board will alarm on ignition failures, compressor lockouts and repeated limit switch trips.
- **Nuisance Trip Protection and Strikes** - To prevent nuisance trouble calls, the control board uses a “three times, you’re out” philosophy. The high and low-pressure switches and the freeze-stats must trip three times within two hours before the unit control board will lock out the associated compressor.
- **On Board Diagnostics** - Each alarm will energize a trouble light on the thermostat, if so equipped, and flash an alarm code on the control board LED. Each high and low-pressure switch alarm as well as each freeze-stat alarm has its own flash code. The control board saves the five most recent alarms in memory, and these alarms can be reviewed at any time. Alarms and programmed values are retained through the loss of power.

All units have long lasting powder paint cabinets with 1000 hour salt spray test approval under ASTM-B117 procedures.

All models are CSA approved.

- **Warranty** - All models include a one-year limited parts warranty on the complete unit. Compressors and electric heater elements carry a five-year warranty. Gas heat exchangers carry a 10-year parts warranty.
- **Gas Heat Operation** - All gas heat units are built with two heating sections for two equal stages of capacity control. Each section includes a durable heat exchanger

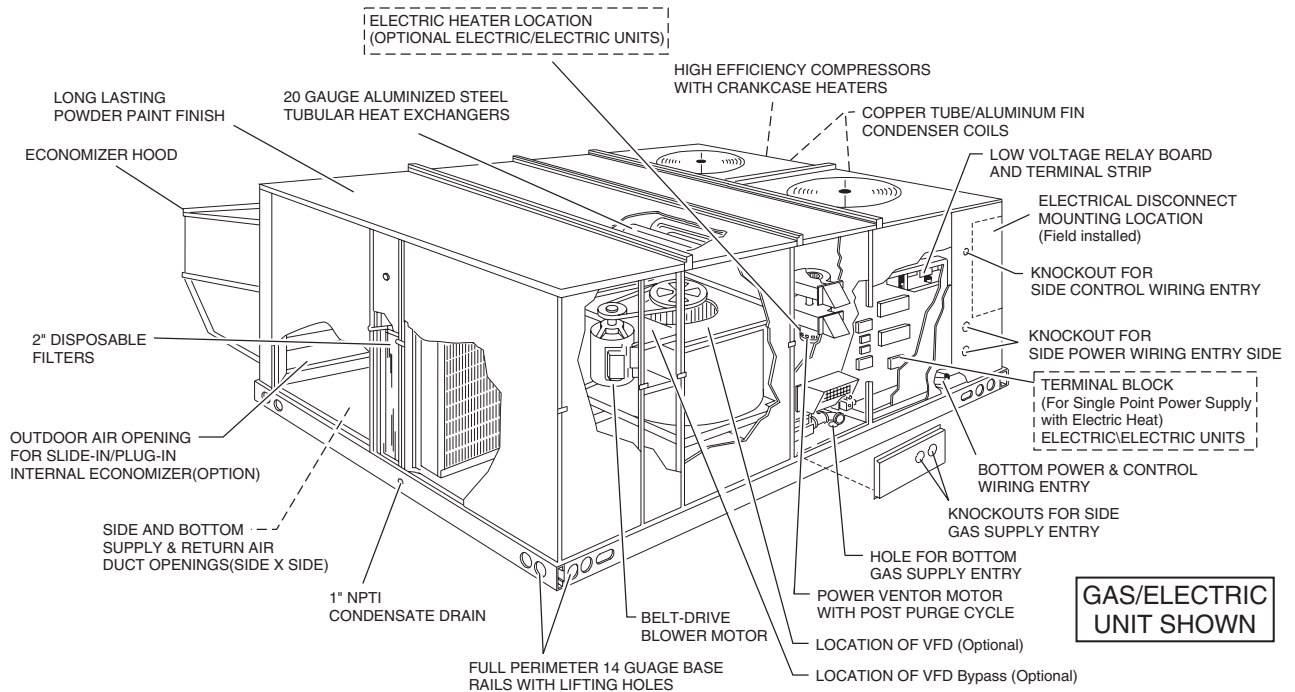

**FIGURE 1 - UNIT CUTAWAY**

with aluminized steel or optional stainless steel tubes, a redundant gas valve, spark ignition, power venting, an ignition module for 100% shut-off and all of the safety controls required to meet the latest ANSI standards.

The gas supply piping can be routed into the heating compartment through a hole in the base pan of the unit or through a knockout in the piping panel on the front of the unit.

- **Electric Heat Operation** - All electric heat models (factory installed only) are wired for a single power source and include a bank of nickel chromium elements mounted at the discharge of the supply air blower to provide a high velocity and uniform distribution of air across the heating elements. Every element is fully protected against excessive current and temperature by fuses and two thermal limit switches.

The power supply wiring can be routed into the control box through a threaded pipe connection in the base pan of the unit or through a knockout in the wiring panel on the front of the unit.

- **BAS Controls** - York's Sunline™ series units offer factory mounted BAS controls such as Simplicity® Intelli-Comfort™, Novar, Honeywell, Johnson, and CPC.

## FACTORY-INSTALLED OPTIONS

- **SINGLE INPUT ELECTRONIC ENTHALPY ECONOMIZERS** - Includes a slide-in / plug-in damper assembly with fully modulating spring-return motor actuator capable of introducing up to 100% outdoor air with nominal 1% leakage type dampers.

The enthalpy system contains one sensor that monitors the outdoor air and determines when the air is cool enough and dry enough to provide free cooling.

The rainhood is painted to match the basic unit and must be field-assembled before installing.

- **BAS-READY ECONOMIZER** - Includes a slide-in / plug-in damper assembly with fully modulating spring-return motor actuator with zero to 95-degree rotation capable of introducing up to 100% outdoor air with nominal 1% leakage type dampers.

Actuator requires 2-10 VDC input from an external source, such as a field-installed or factory-installed BAS controller. BAS-ready actuators have an adjustable auxiliary end-switch for optional power exhaust control.

For units with optional VAV or Simplicity® Intelli-Comfort™ control, a factory-installed, dry bulb sensor determines if outdoor air temperature is low enough to provide free-cooling operation. (Field-installed humidity sensors for either outdoor air or outdoor & return air streams are available for single enthalpy and differential enthalpy configurations, respectively).

The rainhood is painted to match the basic unit and must be field-assembled before installing.

- **POWER EXHAUST** - Our economizer options are available with power exhaust. Whenever the outdoor air intake dampers are opened for free cooling, the exhaust fan will be energized to prevent the conditioned space from being over-pressurized during economizer operation. BAS-ready economizer actuators have an adjustable auxiliary end-switch to provide a range of damper positions available to energize power exhaust. For units with optional VAV,

power exhaust is energized by means of a binary output signal from the unit's VAV control board.

The exhaust fan, motor and controls are installed and wired at the factory. The rain hood must be assembled and installed in the field.

**The power exhaust option can only be used on bottom duct configurations.**

- **MOTORIZED OUTDOOR AIR INTAKE DAMPER** - Includes a slide-in / plug-in damper assembly with a 2-position, spring return motor actuator which opens to a pre-set position whenever the supply air blower is operating and will drive fully closed when the blower unit shuts down.  
  
The rain hood is painted to match the basic unit and must be field assembled before installing.
- **BAROMETRIC RELIEF DAMPER** - This damper option can be used to relieve internal building air pressure on units with an economizer without power exhaust. This accessory includes a rain hood, a bird screen and a fully assembled damper. With bottom duct connections, the damper should be mounted over the opening in the return air panel. With horizontal ductwork, the accessory should be mounted on the return air duct.
- **PHENOLIC COATED EVAPORATOR AND CONDENSER COILS** - Special coating process that utilizes Technicoat 10-1" processes. Coating is applied by total immersion of the complete coil for maximum protection.
- **ELECTRIC HEATERS** wired for single point power supply. These nickel chromium heater elements are provided with limit and automatic reset capability to prevent operation at excessive temperatures.
- **VARIABLE AIR VOLUME (VAV)** - A factory-installed variable frequency drive (VFD), mounted in the Blower Access compartment, is used to control the speed of the indoor blower motor in order to maintain a constant static pressure in the supply duct. A pressure transducer and VAV control board are mounted inside the control box. The drive comes completely wired and pre-programmed from the factory.

An optional, factory-installed manual bypass switch available with factory-installed VFD can be found in the Blower Motor Access compartment. The switch can be used to either route power to the VFD for modulating control of the blower motor, to bypass the drive and operate the motor at full speed, or to power the drive (and not the motor) for diagnostic purposes.

Due to space limitations, VAV is not available with any of the factory-installed BAS options described below, but is available with 'BAS-ready' models. Terminal blocks are provided in the control box for field wiring of the customer-installed BAS.

A 'VFD-ready' option provides the provisions for a customer-installed drive. The unit comes with a mounting bracket installed in the Blower Access compartment which may accommodate other vendor's drives depending on their size. In order to utilize the unit's mounting bracket, the maximum recommended drive dimensions are as follows:

For 5-hp motor applications ..... 10" H x 6" W x 7" D

For 7.5 thru 15-hp motor applications ..... 13" H x 8" W x 8" D

If the drive will not fit in the allotted space, then it will have to be mounted elsewhere; either within the building on a perpendicular wall which is not subjected to excessive temperature, vibration, humidity, dust, corrosive gas, explosive gas, etc., or within an appropriate enclosure rated for outside installation to safeguard against moisture, dust and excessive heat.

A terminal block located in the control box is provided for field connection of the VFD controls.

- **HOT GAS BYPASS** - To allow for low cooling load operation, a direct-acting pressure-modulating bypass control valve installed on the system #1 discharge line is used to divert high temperature, high pressure refrigerant around the TXV in order to maintain a desired minimum evaporator pressure. HGBP is standard on all units with VAV and optional with CV units.
- **FILTER OPTIONS** - Standard units are shipped with 2" throw-away filters installed. 2" pleated and 4" pleated filters are offered as a factory installed option.
- **CONVENIENCE OUTLET** - This 110 volt outlet can be "powered" by the unit with a stepdown transformer or you may order the unit with a "non-powered" convenience outlet that can be wired in the field.
- **DISCONNECT SWITCH** - A HACR breaker sized to the unit max fuse size is provided. Factory installed option only.
- **BAS - Building Automation System Controls (available on two-system cooling product only).**

**Simplicity® INTELLI-Comfort™ CONTROL** - The York® Simplicity® INTELLI-Comfort™ control is factory installed. It includes a supply air sensor, a return air sensor, and an outside air sensor. There are provisions for a field installed dirty filter indicator switch, an air-proving switch, an Outside Air Humidity sensor, a Return Air Humidity sensor, an Inside IAQ sensor, and an Outside Air IAQ sensor. Construction mode operation, 365-day real time clock with 7 day programming plus holiday scheduling is built-in. Two different modes of demand ventilation are achieved through the INTELLI-Comfort™ using CO<sub>2</sub> sensors. It uses an inside CO<sub>2</sub> sensor to perform Demand Ventilation. It can also use an Outside CO<sub>2</sub> sensor to perform Differential Demand Ventilation. It uses a Patented Comfort Ventilation algorithm to provide comfortable ventilation air temperature. The patented

economizer-loading algorithm will protect the equipment when harsh operating conditions exist. Humidity in the occupied space or return duct can be monitored and controlled via humidity sensors and the on-board connection for hot gas re-heat system. It uses the INTELLI-Start™ algorithm to maximize energy savings by recovering the building from the Unoccupied Setpoints to the Occupied Setpoints just in time for the Occupied Time Period to begin. The Simplicity® INTELLI-Comfort™ balances space temperature, ventilation air temperature, CO<sub>2</sub> and humidity for ultimate comfort.

**Simplicity® INTELLI-Comfort™ with ModLINC CONTROL** - The York® Simplicity® INTELLI-Comfort™ with ModLINC control is factory installed. It includes all the features of the INTELLI-Comfort™ control with an additional control to translate communications from MOD-BUS to the BACnet MSTP protocol.

**Novar® BAS CONTROL** - The Novar® ETC-3 building automation system controller is factory installed. Includes supply air sensor, return air sensor, dirty filter indicator switch, and air proving switch.

**JOHNSON CONTROLS BAS CONTROL** - The Johnson Control YK-UNT-1126 building automation system controller is factory installed. Includes supply air sensor, return air sensor, dirty filter indicator switch, and air proving switch.

**CPC BAS CONTROL** - The Computer Process Controls Model 810-3060 ARTC Advanced Rooftop building automation system controller is factory installed. Includes supply air sensor, return air sensor, dirty filter indicator switch and air proving switch.

**HONEYWELL BAS CONTROL** - The Honeywell W7750C building automation system controller is factory installed. Includes air supply sensor, return air sensor, dirty filter indicator switch, and air proving switch.

- **SMOKE DETECTORS** - (supply air & return air) The smoke detectors stop operation of the unit by interrupting power to the control board if smoke is detected within the air compartment.

## ▲ WARNING

Factory installed smoke detectors in the return air, may be subjected to freezing temperatures during "off" times due to outside air infiltration. These smoke detectors have an operational limit of 32°F to 131°F. Smoke detectors installed in areas that could be outside those limitations will have to be moved to prevent having false alarms.

- **COIL GUARD** - Customers can purchase a coil guard kit to protect the condenser coil from damage. This is not a hail guard kit.
- **STAINLESS STEEL HEAT EXCHANGER** - For applications in corrosive environments, this option provides a full stainless steel heat exchanger assembly.
- **STAINLESS STEEL DRAIN PAN** - An optional rust-proof stainless steel drain pan is available to provide years of trouble-free operation in corrosive environments.
- **PHASE MONITORS** - Designed to prevent unit damage. The phase monitor will shut the unit down in an out-of-phase condition.
- **HIGH STATIC DRIVE** - May include a belt, blower pulley, motor pulley or a motor change to enhance blower performance.
- **DIRTY FILTER SWITCH** - This kit includes a differential pressure switch that energizes the fault light on the unit thermostat, indicating that there is an abnormally high pressure drop across the filters. Factory installed option or field installed accessory.
- **HINGED FILTER DOOR/"TOOL FREE" BLOWER AND ACCESS PANELS (not hinged)** - This option allows for easy access and maintenance.

**NOTE:** Knobs are shipped separately within the unit to prevent shipping damage. These must be field installed for tool free operation.

- **HINGED/"TOOL FREE" BLOWER, BLOWER MOTOR, FILTER AND ELECTRIC ACCESS PANELS** - This option allows for complete hinged and tool free access to the unit's blower, blower motor, filters and electrical panel sections.

## FIELD-INSTALLED ACCESSORIES

- **SINGLE INPUT ELECTRONIC ENTHALPY ECONOMIZERS** - Includes a slide-in / plug-in damper assembly with fully modulating spring-return motor actuator capable of introducing up to 100% outdoor air with nominal 1% leakage type dampers.

The enthalpy system contains one sensor that monitors the outdoor air and determines when the air is cool enough and dry enough to provide free cooling.

The rainhood is painted to match the basic unit and must be field-assembled before installing.

- **MOTORIZED OUTDOOR AIR INTAKE DAMPER** - Includes a slide-in / plug-in damper assembly with a 2-position, spring return motor actuator which opens to some pre-set position whenever the supply air blower is operating and will drive fully closed when the blower unit shuts down.

The rain hood is painted to match the basic unit and must be field assembled before installing.

- **ROOF CURBS** - Fourteen-inch high roof curbs provide a water-tight seal between the unit and the finished roof. These full perimeter curbs meet the requirements of the National Roofing Contractors Association (NRCA) and are shipped knocked-down for field assembly.

They're designed to fit inside the base rails of the unit and include both a wood nailing strip and duct hanger supports.

- **HIGH ALTITUDE NATURAL GAS** - Burner orifices and pilot orifices are provided for proper furnace operation at altitudes up to 6,000 feet.
- **PROPANE** - Burner orifices, pilot orifices and gas valve parts are provided to convert a natural gas furnace to propane.
- **HIGH ALTITUDE PROPANE** - Burner orifices and pilot orifices are provided for proper furnace operation at alti-

tudes up to 6,000 feet. This accessory supplements the basic propane conversion kit.

- **SIDE DUCT FLANGES** - One-inch flanges replace the supply and return air panels on the rear of the unit to accommodate horizontal duct connections. These flanges can also be used individually for bottom supply/horizontal return or horizontal supply/bottom return. They cannot be used on units with power exhaust.
- **BAROMETRIC RELIEF DAMPER** - This damper accessory can be used to relieve internal building air pressure on units with an economizer without power exhaust. This accessory includes a rain hood, a bird screen and a fully assembled damper. With bottom duct connections, the damper should be mounted over the opening in the return air panel. With horizontal ductwork, the accessory should be mounted on the return air duct.
- **HIGH STATIC DRIVE** - May include a belt, blower pulley, motor pulley or a motor change to enhance blower performance.
- **ENTHALPY ACCESSORY CONTROL KIT** - This kit contains the required components to convert a single enthalpy economizer to dual enthalpy.
- **BURGLAR BARS** - Mount in the supply and return openings to prevent entry into the duct work.
- **FLUE EXHAUST EXTENSION KIT** - In locations with wind or weather conditions which may interfere with proper exhausting of furnace combustion products, this kit can be installed to prevent the flue exhaust from entering nearby fresh air intakes.
- **WOOD SKID** - Allows unit to be handled with 90" forks.
- **CO<sub>2</sub> SENSOR** - Senses CO<sub>2</sub> levels and automatically overrides the economizer when levels rise above the present limits.
- **COIL GUARD** - Customers can purchase a coil guard kit to protect the condenser coil from damage. This is not a hail guard kit.
- **PHASE MONITORS** - Designed to prevent unit damage. The phase monitor will shut the unit down in an out-of-phase condition.



**TABLE 1: INDOOR SOUND POWER RATING<sup>1</sup>**

UNIT SIZE	CFM	ESP	BLOWER		SOUND POWER (db 10 <sup>-12</sup> Watts)									
					Octave Band Centerline Frequency (Hz)								SWL dB(A)	dB(A) @ 10Ft. <sup>2</sup>
					IWG	RPM	BHP	63	125	250	500	1,000		
180	6,000	1.00	1,080	4.60	99	99	89	82	84	77	72	67	89	56
210, 240	8,000	1.00	1,120	6.65	102	102	92	85	87	80	75	70	92	59
300	10,000	1.30	1,160	12.5	108	108	98	91	93	86	81	76	98	65

1. These values have been accessed using a model of sound propagation from a point source into the hemispheric/free field. The dBA values provided are to be used for reference only. Calculation of dBA values cover matters of system design and the fan manufacture has no way of knowing the details of each system. This constitutes an expectation to any specification or guarantee requiring a dBA value or sound data in any other form than sound power level ratings.
2. At a distance of 10 feet from the blower.

**TABLE 2: CAPACITY RATINGS - (ARI 360)<sup>1</sup>**

MODEL	MBH	EER <sup>2</sup>	IPLV <sup>3</sup>
<b>COOLING ONLY</b>			
DH180C/E00	178 <sup>4</sup>	10.8	11.3
DH210C/E00	205	10.2	10.8
DH240C/E00	223	9.7	10.2
DH300C/E00	271	9.6	9.6
<b>COOLING WITH GAS HEAT</b>			
DH180N/S	178 <sup>4</sup>	10.8	11.3
DH210N/S	205	10.2	10.8
DH240N/S	223	9.7	10.2
DH300N/S	271	9.6	9.6
<b>COOLING WITH ELECTRIC HEAT</b>			
DH180E18	178 <sup>4</sup>	10.8	11.3
DH180E36	178 <sup>4</sup>	10.8	11.3
DH180E54	176 <sup>4</sup>	10.5	11.0
DH180E72	176 <sup>4</sup>	10.5	11.0
DH210E18	205	10.2	10.8
DH210E36	205	10.2	10.8
DH210E54	203	10.0	10.6
DH210E72	203	10.0	10.6
DH240E18	223	9.6	10.1
DH240E36	223	9.6	10.1
DH240E54	221	9.5	9.7
DH240E72	219	9.5	9.7
DH300E18	271	9.6	9.6
DH300E36	271	9.6	9.6
DH300E54	269	9.5	9.4
DH300E72	269	9.5	9.4

1. 80/67°F Indoor and 95°F outdoor.
2. EER = Energy Efficiency Ratio at full load - the cooling capacity in Btu's per hour (Btuh) divided by the power input in watts, expressed in Btuh per watt (Btuh/watt).
3. IPLV = Integrated part load value.
4. Deduct 2 MBH @ 208V.

**TABLE 3: GAS HEAT RATINGS<sup>1</sup>**

MODEL	MBH INPUT	MBH OUTPUT
DH180N/S24	300	240
DH180N/S32	400	320
DH210N/S24	300	240
DH210N/S32	400	320
DH240N/S24	300	240
DH240N/S32	400	320
DH300N/S24	300	240
DH300N/S32	400	320

1. All units are two-stage heating. First stage is 50% of total. SSE = Steady State Efficiency (80%) - Output divided by Input

**⚠ CAUTION**

For units with VFD and electric or gas heat, the speed of the indoor blower motor continues to be controlled by duct static pressure via the VAV control board.

If there are VAV boxes present in the duct system, the boxes must be driven to the full-open position using a customer-supplied power source to assure adequate airflow across electric heating elements or gas heat exchanger tubes.

**TABLE 4: DH 180 COOLING CAPACITIES (15 TON)**

AIR ON EVAPORATOR COIL		TEMPERATURE OF AIR ON CONDENSER COIL															
		75°F									85°F						
		TOTAL CAP. <sup>1</sup> MBH	POWER INPUT <sup>2</sup> KW	SENSIBLE CAPACITY, MBH							TOTAL CAP. <sup>1</sup> MBH	POWER INPUT <sup>2</sup> KW	SENSIBLE CAPACITY, MBH				
				ENTERING DRY BULB, °F									ENTERING DRY BULB, °F				
CFM	WB °F			90	85	80	75	70	65			90	85	80	75	70	65
4500	77	223.0	11.3	100.4	79.0	57.7	-	-	-	218.1	12.9	99.3	77.9	56.5	-	-	-
	72	211.0	11.2	133.1	111.7	90.3	68.9	-	-	203.0	12.6	130.5	109.2	87.8	66.4	-	-
	67	199.0	11.1	165.8	144.4	123.0	101.6	80.2	-	188.0	12.3	161.8	140.4	119.0	97.6	76.2	-
	62	181.3	10.8	181.3	178.6	157.3	135.9	114.5	93.1	173.0	12.1	173.0	169.9	148.5	127.2	105.8	84.4
	57	178.5	10.5	178.5	179.1	162.3	140.9	119.6	98.2	170.1	12.1	170.1	170.1	151.1	129.7	108.3	86.9
5250	77	231.5	11.3	107.2	87.6	62.3	-	-	-	225.0	12.9	112.3	87.0	61.8	-	-	-
	72	219.0	11.2	148.2	122.9	97.7	72.4	-	-	209.5	12.6	146.4	121.2	95.9	70.6	-	-
	67	206.5	11.2	189.2	158.3	133.0	107.7	82.5	-	194.0	12.4	180.5	155.3	130.0	104.7	79.5	-
	62	188.1	10.9	188.1	186.8	170.1	144.9	119.6	94.3	178.5	12.2	178.5	177.0	162.3	137.0	111.7	86.5
	57	185.3	10.6	185.3	185.5	175.7	150.4	125.1	99.8	175.6	12.2	175.6	175.6	165.0	139.8	114.5	89.2
6000	77	240.0	11.4	114.0	96.2	67.0	-	-	-	232.0	13.0	125.3	96.2	67.0	-	-	-
	72	227.0	11.3	163.3	134.2	105.0	75.8	-	-	216.0	12.7	162.3	133.2	104.0	74.8	-	-
	67	214.0	11.2	212.6	172.2	143.0	113.8	84.7	-	200.0	12.4	199.3	170.2	141.0	111.8	82.7	-
	62	195.0	10.9	195.0	195.0	183.0	153.8	124.7	95.5	184.0	12.2	184.0	184.0	176.0	146.8	117.7	88.5
	57	192.0	10.6	192.0	192.0	189.0	159.8	130.7	101.5	181.0	12.2	181.0	181.0	179.0	149.8	120.7	91.5
6750	72	226.4	11.2	178.0	144.8	111.6	78.4	-	-	217.6	12.8	176.0	142.7	109.5	76.3	-	-
	67	213.5	11.2	212.8	185.2	152.0	118.8	85.6	-	201.5	12.5	201.2	181.7	148.5	115.3	82.1	-
	62	194.5	10.8	194.5	194.5	188.5	155.3	122.1	88.9	185.4	12.2	185.4	185.4	181.4	148.2	115.0	81.8
	57	191.5	10.5	191.5	191.5	190.0	156.8	123.6	90.4	182.4	12.2	182.4	182.4	181.4	148.1	114.9	81.7
	72	225.8	11.2	192.8	155.5	118.2	81.0	-	-	219.2	12.8	189.6	152.3	115.1	77.8	-	-
7500	67	213.0	11.1	213.0	198.3	161.0	123.7	86.5	-	203.0	12.5	203.0	193.3	156.0	118.7	81.5	-
	62	194.0	10.8	194.0	194.0	194.0	156.7	119.5	82.2	186.8	12.3	186.8	186.8	186.8	149.5	112.2	75.0
	57	191.0	10.5	191.0	191.0	191.0	153.8	116.5	79.3	183.7	12.3	183.7	183.7	183.7	146.5	109.2	71.9

AIR ON EVAPORATOR COIL		TEMPERATURE OF AIR ON CONDENSER COIL															
		95°F									105°F						
		TOTAL CAP. <sup>1</sup> MBH	POWER INPUT <sup>2</sup> KW	SENSIBLE CAPACITY, MBH							TOTAL CAP. <sup>1</sup> MBH	POWER INPUT <sup>2</sup> KW	SENSIBLE CAPACITY, MBH				
				ENTERING DRY BULB, °F									ENTERING DRY BULB, °F				
CFM	WB °F			90	85	80	75	70	65			90	85	80	75	70	65
4500	77	213.2	14.5	98.2	76.8	55.4	-	-	-	198.8	16.1	97.0	75.6	54.2	-	-	-
	72	195.1	14.0	128.0	106.6	85.2	63.8	-	-	182.7	15.4	125.1	103.7	82.4	61.0	-	-
	67	177.0	13.5	157.8	136.4	115.0	93.6	72.2	-	166.5	14.8	153.3	131.9	110.5	89.1	67.7	-
	62	164.6	13.4	164.6	161.2	139.8	118.4	97.1	75.7	155.6	14.7	155.6	153.8	135.7	114.3	93.0	71.6
	57	161.8	13.7	161.8	161.2	139.8	118.4	97.1	75.7	152.2	15.0	152.2	151.9	134.0	112.6	91.3	69.9
5250	77	218.6	14.5	117.4	86.5	61.2	-	-	-	203.9	16.2	117.3	84.6	59.4	-	-	-
	72	200.0	14.0	144.7	119.4	94.1	68.8	-	-	187.3	15.5	140.7	115.5	90.2	64.9	-	-
	67	181.5	13.6	171.9	152.3	127.0	101.7	76.5	-	170.8	14.8	164.1	146.3	121.0	95.7	70.5	-
	62	168.8	13.5	168.8	167.1	154.4	129.1	103.9	78.6	159.5	14.8	159.5	158.7	148.6	123.3	98.1	72.8
	57	165.9	13.7	165.9	165.6	154.4	129.1	103.9	78.6	156.1	15.1	156.1	156.0	146.8	121.5	96.2	70.9
6000	77	224.0	14.6	136.6	96.2	67.0	-	-	-	209.0	16.3	137.6	93.7	64.5	-	-	-
	72	205.0	14.1	161.3	132.2	103.0	73.8	-	-	192.0	15.6	156.3	127.2	98.0	68.8	-	-
	67	186.0	13.6	186.0	168.2	139.0	109.8	80.7	-	175.0	14.9	175.0	160.7	131.5	102.3	73.2	-
	62	173.0	13.5	173.0	173.0	169.0	139.8	110.7	81.5	163.5	14.9	163.5	163.5	161.5	132.3	103.2	74.0
	57	170.0	13.8	170.0	170.0	169.0	139.8	110.7	81.5	160.0	15.2	160.0	160.0	159.5	130.3	101.2	72.0
6750	72	208.9	14.3	173.9	140.7	107.4	74.2	-	-	195.8	15.7	170.2	137.0	103.8	70.6	-	-
	67	189.5	13.8	189.5	178.2	145.0	111.8	78.6	-	178.5	15.0	178.5	170.1	139.3	106.0	72.8	-
	62	176.3	13.6	176.3	176.3	174.3	141.0	107.8	74.6	166.8	15.0	166.8	166.8	165.8	132.6	99.4	66.1
	57	173.2	14.0	173.2	173.2	172.7	139.5	106.3	73.1	163.2	15.3	163.2	163.2	163.0	129.7	96.5	63.3
	72	212.7	14.4	186.4	149.2	111.9	74.6	-	-	199.7	15.9	184.1	146.8	109.6	72.3	-	-
7500	67	193.0	13.9	193.0	188.3	151.0	113.7	76.5	-	182.0	15.2	182.0	179.6	147.0	109.7	72.5	-
	62	179.5	13.8	179.5	179.5	179.5	142.3	105.0	67.7	170.0	15.1	170.0	170.0	170.0	132.8	95.5	58.3
	57	176.4	14.1	176.4	176.4	176.4	139.1	101.9	64.6	166.4	15.5	166.4	166.4	166.4	129.1	91.9	54.6

**TABLE 4: DH 180 COOLING CAPACITIES (15 TON) (CONTINUED)**

AIR ON EVAPORATOR COIL		TEMPERATURE OF AIR ON CONDENSER COIL							
		115°F							
		TOTAL CAP. <sup>1</sup> MBH	POWER INPUT <sup>2</sup> KW	SENSIBLE CAPACITY, MBH					
ENTERING DRY BULB, °F									
CFM	WB °F			90	85	80	75	70	65
4500	77	184.5	17.8	95.8	74.4	53.0	-	-	-
	72	170.3	16.9	122.3	100.9	79.5	58.1	-	-
	67	156.0	16.0	148.8	127.4	106.0	84.6	63.2	-
	62	146.5	16.1	146.5	146.5	131.6	110.3	88.9	67.5
	57	142.7	16.4	142.7	142.7	128.2	106.8	85.5	64.1
5250	77	189.3	17.9	117.2	82.8	57.5	-	-	-
	72	174.6	17.0	136.8	111.5	86.3	61.0	-	-
	67	160.0	16.1	156.4	140.3	115.0	89.7	64.5	-
	62	150.2	16.2	150.2	150.2	142.8	117.6	92.3	67.0
	57	146.3	16.5	146.3	146.3	139.1	113.8	88.6	63.3
6000	77	194.0	18.0	138.6	91.2	62.0	-	-	-
	72	179.0	17.1	151.3	122.2	93.0	63.8	-	-
	67	164.0	16.2	164.0	153.2	124.0	94.8	65.7	-
	62	154.0	16.3	154.0	154.0	154.0	124.8	95.7	66.5
	57	150.0	16.6	150.0	150.0	150.0	120.8	91.7	62.5
6750	72	182.8	17.2	166.5	133.3	100.1	66.9	-	-
	67	167.5	16.3	167.5	162.1	133.5	100.3	67.1	-
	62	157.3	16.4	157.3	157.3	157.3	124.1	90.9	57.7
	57	153.2	16.7	153.2	153.2	153.2	120.0	86.8	53.6
7500	72	186.6	17.3	181.8	144.5	107.3	70.0	-	-
	67	171.0	16.4	171.0	171.0	143.0	105.7	68.5	-
	62	160.6	16.5	160.6	160.6	160.6	123.3	86.1	48.8
	57	156.4	16.8	156.4	156.4	156.4	119.1	81.9	44.6

1. These capacities are gross ratings. For net capacity, deduct the air blower motor, MBH = 3.415 x KW. Refer to the appropriate Blower Performance Table for the KW of the supply air blower motor.
2. These ratings include the condenser fan motors (Total 2.3 KW) and the compressor motors but not the supply air blower motor.

 Nominal Rating

TABLE 5: DH 210 COOLING CAPACITIES (17.5 TON)

AIR ON EVAPORATOR COIL		TEMPERATURE OF AIR ON CONDENSER COIL																
		75°F									85°F							
		TOTAL CAP. <sup>1</sup> MBH	POWER INPUT <sup>2</sup> KW	SENSIBLE CAPACITY, MBH							TOTAL CAP. <sup>1</sup> MBH	POWER INPUT <sup>2</sup> KW	SENSIBLE CAPACITY, MBH					
				ENTERING DRY BULB, °F									ENTERING DRY BULB, °F					
CFM	WB °F	90	85	80	75	70	65	90	85	80	75	70	65					
5250	77	241.5	13.9	119.5	94.6	69.6	-	-	-	240.2	15.6	119.7	94.8	69.9	-	-	-	
	72	232.2	13.2	159.7	134.8	109.8	84.9	-	-	226.1	15.1	156.3	131.4	106.4	81.5	-	-	
	67	223.0	12.6	199.9	174.9	150.0	125.1	100.1	-	212.0	14.5	192.9	167.9	143.0	118.1	93.1	-	
	62	204.4	12.4	204.4	204.4	182.1	157.1	132.2	107.2	193.5	14.3	193.5	193.5	170.5	145.5	120.6	95.6	
	57	200.4	12.6	200.4	200.4	183.1	158.2	133.2	108.3	191.2	14.3	191.2	191.2	171.8	146.9	121.9	97.0	
6125	77	250.1	14.5	136.3	104.8	75.3	-	-	-	248.8	16.0	140.3	105.8	76.3	-	-	-	
	72	240.5	13.8	177.8	148.3	118.9	89.4	-	-	234.2	15.4	175.2	145.7	116.2	86.7	-	-	
	67	231.0	13.1	219.4	191.9	162.4	132.9	103.4	-	219.6	14.9	210.0	185.6	156.2	126.7	97.2	-	
	62	211.7	12.9	211.7	211.7	197.2	167.7	138.2	108.7	200.5	14.7	200.5	200.5	186.1	156.6	127.2	97.7	
	57	207.6	13.1	207.6	207.6	198.3	168.8	139.3	109.9	198.0	14.7	198.0	198.0	187.6	158.1	128.6	99.1	
7000	77	258.7	15.1	153.0	115.0	81.0	-	-	-	257.4	16.4	160.9	116.7	87.7	-	-	-	
	72	248.8	14.4	195.9	161.9	127.9	93.9	-	-	242.3	15.8	194.0	160.0	126.0	92.0	-	-	
	67	238.9	13.7	238.9	208.8	174.8	140.8	106.8	-	227.2	15.2	227.2	203.3	169.3	135.3	101.3	-	
	62	219.0	13.5	219.0	219.0	212.3	178.3	144.3	110.2	207.4	15.0	207.4	207.4	201.8	167.8	133.8	99.7	
	57	214.7	13.7	214.7	214.7	213.5	179.5	145.5	111.4	204.9	15.0	204.9	204.9	203.4	169.4	135.4	101.3	
7875	72	253.0	14.5	214.9	176.1	137.4	98.6	-	-	246.9	15.9	212.6	173.9	135.2	96.4	-	-	
	67	243.0	13.8	243.0	227.9	187.8	149.0	110.3	-	231.6	15.3	231.6	219.6	181.6	142.9	104.1	-	
	62	222.7	13.6	222.7	222.7	219.4	180.6	141.9	103.1	211.4	15.1	211.4	211.4	208.6	169.8	131.1	92.3	
	57	218.3	13.8	218.3	218.3	217.7	179.0	140.2	101.5	208.8	15.1	208.8	208.8	208.1	169.3	130.6	91.8	
	72	257.2	14.6	233.8	190.3	146.9	103.4	-	-	251.6	16.0	231.2	187.8	144.3	100.8	-	-	
8750	67	247.0	13.9	247.0	247.0	200.7	157.2	113.8	-	235.9	15.4	235.9	235.9	193.9	150.4	107.0	-	
	62	226.4	13.7	226.4	226.4	226.4	183.0	139.5	96.0	215.3	15.2	215.3	215.3	215.3	171.9	128.4	84.9	
	57	222.0	13.9	222.0	222.0	222.0	178.5	135.0	91.6	212.7	15.2	212.7	212.7	212.7	169.3	125.8	82.3	

AIR ON EVAPORATOR COIL		TEMPERATURE OF AIR ON CONDENSER COIL																
		95°F									105°F							
		TOTAL CAP. <sup>1</sup> MBH	POWER INPUT <sup>2</sup> KW	SENSIBLE CAPACITY, MBH							TOTAL CAP. <sup>1</sup> MBH	POWER INPUT <sup>2</sup> KW	SENSIBLE CAPACITY, MBH					
				ENTERING DRY BULB, °F									ENTERING DRY BULB, °F					
CFM	WB °F	90	85	80	75	70	65	90	85	80	75	70	65					
5250	77	238.9	17.4	120.0	95.0	70.1	-	-	-	228.3	15.0	116.1	91.2	66.2	-	-	-	
	72	219.9	16.9	152.9	128.0	103.0	78.1	-	-	209.9	14.6	148.0	123.0	98.1	73.1	-	-	
	67	201.0	16.5	185.9	160.9	136.0	111.1	86.1	-	191.5	14.2	179.8	154.8	129.9	105.0	80.0	-	
	62	182.6	16.3	182.6	182.6	158.8	133.9	108.9	84.0	176.2	14.0	176.2	176.2	152.7	127.8	102.9	77.9	
	57	182.0	16.1	182.0	182.0	160.5	135.5	110.6	85.6	176.4	13.9	176.4	176.4	153.3	128.3	103.4	78.4	
6125	77	247.5	17.6	144.4	106.7	77.2	-	-	-	235.7	17.2	143.3	102.8	73.3	-	-	-	
	72	235.0	17.2	172.5	143.1	124.0	84.1	-	-	223.4	19.0	167.5	138.0	108.6	79.1	-	-	
	67	215.5	16.7	200.7	179.4	163.8	120.4	90.9	-	203.8	18.5	191.8	173.3	143.8	114.3	84.8	-	
	62	195.8	16.5	189.2	189.2	191.3	145.6	116.1	86.6	187.4	18.2	181.8	181.8	169.1	139.6	110.1	80.6	
	57	195.1	16.3	188.5	188.5	193.3	147.4	117.9	88.4	187.8	18.1	182.1	182.1	169.7	140.2	110.7	81.2	
7000	77	256.1	17.7	168.8	118.4	84.4	-	-	-	243.0	19.5	170.4	114.4	80.4	-	-	-	
	72	235.8	17.2	192.1	158.1	124.1	90.1	-	-	223.4	19.0	187.1	153.1	119.1	85.0	-	-	
	67	215.5	16.7	215.5	197.8	163.8	129.8	95.8	-	203.8	18.5	203.8	191.7	157.7	123.7	89.7	-	
	62	195.8	16.5	195.8	195.8	191.3	157.3	123.3	89.2	187.5	18.2	187.5	187.5	185.5	151.4	117.4	83.4	
	57	195.1	16.3	195.1	195.1	193.3	159.3	125.3	91.2	187.8	18.1	187.8	187.8	186.1	152.0	118.0	84.0	
7875	72	240.9	17.3	210.4	171.7	132.9	94.2	-	-	228.3	19.1	205.3	166.5	127.8	89.0	-	-	
	67	220.2	16.8	220.2	211.3	175.5	136.7	98.0	-	208.3	18.6	208.3	202.2	169.3	130.5	91.8	-	
	62	200.0	16.6	200.0	200.0	197.8	159.0	120.3	81.5	191.6	18.3	191.6	191.6	190.6	151.8	113.1	74.3	
	57	199.3	16.4	199.3	199.3	198.4	159.7	120.9	82.2	191.9	18.2	191.9	191.9	191.0	152.3	113.5	74.8	
	72	246.0	17.4	228.7	185.2	141.8	98.3	-	-	233.2	19.2	223.5	180.0	136.5	93.1	-	-	
8750	67	224.8	16.9	224.8	224.8	187.1	143.6	100.2	-	212.8	18.7	212.8	212.8	180.9	137.4	93.9	-	
	62	204.2	16.7	204.2	204.2	204.2	160.8	117.3	73.8	195.7	18.4	195.7	195.7	195.7	152.2	108.7	65.3	
	57	203.5	16.5	203.5	203.5	203.5	160.0	116.6	73.1	196.0	18.3	196.0	196.0	196.0	152.5	109.1	65.6	

**TABLE 5: DH 210 COOLING CAPACITIES (17.5 TON) (CONTINUED)**

AIR ON EVAPORATOR COIL		TEMPERATURE OF AIR ON CONDENSER COIL															
		115°F								125°F							
		TOTAL CAP. <sup>1</sup> MBH	POWER INPUT <sup>2</sup> KW	SENSIBLE CAPACITY, MBH						TOTAL CAP. <sup>1</sup> MBH	POWER INPUT <sup>2</sup> KW	SENSIBLE CAPACITY, MBH					
				ENTERING DRY BULB, °F								ENTERING DRY BULB, °F					
CFM	WB °F			90	85	80	75	70	65			90	85	80	75	70	65
5250	77	217.8	12.5	112.3	87.3	62.4	-	-	-	207.3	10.1	108.4	83.5	58.5	-	-	-
	72	199.9	12.2	143.0	118.0	93.1	68.1	-	-	189.9	9.9	138.0	113.1	88.1	63.2	-	-
	67	182.0	12.0	173.7	148.7	123.8	98.9	73.9	-	172.5	9.7	167.6	142.6	117.7	92.8	67.8	-
	62	169.7	11.8	169.7	169.7	146.7	121.7	96.8	71.8	163.2	9.5	163.2	163.2	140.6	115.6	90.7	65.7
	57	170.9	11.8	170.9	170.9	146.0	121.1	96.1	71.2	165.4	9.6	165.4	165.4	138.8	113.8	88.9	63.9
6125	77	223.9	16.9	142.1	98.9	69.4	-	-	-	212.0	16.5	141.0	95.0	65.5	-	-	-
	72	205.5	16.5	162.5	133.0	103.5	74.1	-	-	194.2	16.2	157.5	128.0	98.5	69.1	-	-
	67	187.1	16.1	182.9	167.2	137.7	108.2	78.7	-	176.5	15.8	174.0	161.1	131.6	102.1	72.6	-
	62	174.4	15.8	174.4	174.4	163.1	133.6	104.2	74.7	167.0	15.6	167.0	167.0	157.2	127.7	98.2	68.7
	57	175.7	15.8	175.7	175.7	162.4	132.9	103.4	74.0	169.2	15.7	169.2	169.2	155.2	125.7	96.2	66.7
7000	77	229.9	21.2	172.0	110.4	76.4	-	-	-	216.8	23.0	173.6	106.4	72.4	-	-	-
	72	211.0	20.7	182.0	148.0	114.0	80.0	-	-	198.6	22.5	177.0	143.0	109.0	74.9	-	-
	67	192.1	20.2	192.1	185.6	151.6	117.6	83.6	-	180.4	22.0	180.4	179.5	145.5	111.5	77.5	-
	62	179.1	19.9	179.1	179.1	179.6	145.6	111.6	77.5	170.8	21.6	170.8	170.8	170.8	139.7	105.7	71.7
	57	180.4	19.9	180.4	180.4	178.8	144.8	110.8	76.7	173.1	21.7	173.1	173.1	171.6	137.5	103.5	69.5
7875	72	215.7	20.8	200.1	161.4	122.6	83.9	-	-	203.1	22.6	195.0	156.3	117.5	78.8	-	-
	67	196.4	20.3	196.4	193.2	163.1	124.4	85.6	-	184.5	22.1	184.5	184.1	156.9	118.2	79.4	-
	62	183.1	20.0	183.1	183.1	183.4	144.6	105.9	67.1	174.7	21.7	174.7	174.7	174.7	137.4	98.7	59.9
	57	184.4	20.0	184.4	184.4	183.6	144.9	106.1	67.4	177.0	21.8	177.0	177.0	176.3	137.5	98.8	60.0
8750	72	220.4	20.9	218.2	174.8	131.3	87.8	-	-	207.7	22.7	207.7	169.5	126.1	82.6	-	-
	67	200.7	20.4	200.7	200.7	174.6	131.1	87.7	-	188.7	22.2	188.7	188.7	168.4	124.9	81.4	-
	62	187.1	20.1	187.1	187.1	187.1	143.6	100.2	56.7	178.6	21.8	178.6	178.6	178.6	135.1	91.6	48.1
	57	188.5	20.1	188.5	188.5	188.5	145.0	101.5	58.1	181.0	21.9	181.0	181.0	181.0	137.5	94.0	50.5

1. These capacities are gross ratings. For net capacity, deduct the air blower motor, MBH = 3.415 x KW. Refer to the appropriate Blower Performance Table for the KW of the supply air blower motor.
2. These ratings include the condenser fan motors (Total 1 KW) and the compressor motors but not the supply air blower motor.

Nominal Rating

**TABLE 6: DH 240 COOLING CAPACITIES (20 TON)**

AIR ON EVAPORATOR COIL		TEMPERATURE OF AIR ON CONDENSER COIL															
		75°F									85°F						
		TOTAL CAP. <sup>1</sup> MBH	POWER INPUT <sup>2</sup> KW	SENSIBLE CAPACITY, MBH							TOTAL CAP. <sup>1</sup> MBH	POWER INPUT <sup>2</sup> KW	SENSIBLE CAPACITY, MBH				
				ENTERING DRY BULB, °F									ENTERING DRY BULB, °F				
CFM	WB °F	90	85	80	75	70	65	90	85	80	75	70	65				
6000	77	277.0	19.1	159.2	130.7	102.2	-	-	-	262.0	20.5	153.7	125.2	96.7	-	-	-
	72	263.0	18.6	196.1	167.6	139.1	110.6	-	-	249.0	20.1	190.4	161.8	133.3	104.8	-	-
	67	249.0	18.0	233.0	204.5	176.0	147.5	119.0	-	236.0	19.6	227.0	198.5	170.0	141.5	113.0	-
	62	240.6	17.9	240.6	240.6	215.3	186.8	158.3	129.8	228.6	19.4	228.6	228.6	204.2	175.7	147.1	118.6
	57	237.8	17.7	237.8	237.8	213.7	185.2	156.7	128.1	226.7	19.1	226.7	226.7	203.3	174.8	146.3	117.8
7000	77	287.0	17.9	189.9	145.8	112.1	-	-	-	272.0	19.4	187.6	140.0	106.3	-	-	-
	72	272.5	17.4	219.9	186.3	152.6	118.9	-	-	258.5	18.9	214.1	180.4	146.7	113.0	-	-
	67	258.0	16.9	250.0	226.7	193.0	159.3	125.6	-	245.0	18.5	240.5	220.7	187.0	153.3	119.6	-
	62	249.3	16.7	249.3	249.3	236.2	202.5	168.8	135.1	237.3	18.3	237.3	237.3	224.6	190.9	157.2	123.5
	57	246.4	16.5	246.4	246.4	234.3	200.6	166.9	133.3	235.4	18.1	235.4	235.4	223.7	190.0	156.3	122.6
8000	77	297.0	16.7	220.5	160.9	122.0	-	-	-	282.0	18.2	221.5	154.9	116.0	-	-	-
	72	282.0	16.2	243.8	204.9	166.0	127.1	-	-	268.0	17.8	237.8	198.9	160.0	121.1	-	-
	67	267.0	15.7	267.0	248.9	210.0	171.1	132.2	-	254.0	17.4	254.0	242.9	204.0	165.1	126.2	-
	62	258.0	15.6	258.0	258.0	257.0	218.1	179.2	140.4	246.0	17.2	246.0	246.0	245.0	206.1	167.2	128.4
	57	255.0	15.4	255.0	255.0	255.0	216.1	177.2	138.4	244.0	17.0	244.0	244.0	244.0	205.1	166.2	127.4
9000	72	295.2	13.7	275.1	228.1	183.8	139.5	-	-	280.7	15.3	265.0	220.8	176.5	132.2	-	-
	67	279.5	13.3	279.5	270.4	232.5	188.2	143.9	-	266.0	15.0	266.0	260.4	225.0	180.7	136.4	-
	62	270.1	13.2	270.1	270.1	269.6	225.3	181.0	136.7	257.6	14.8	257.6	257.6	257.1	212.8	168.6	124.3
	57	266.9	13.0	266.9	266.9	266.9	222.7	178.4	134.1	255.5	14.6	255.5	255.5	255.5	211.2	167.0	122.7
	72	308.4	11.2	306.4	251.2	201.5	151.9	-	-	293.3	12.8	292.3	242.6	192.9	143.3	-	-
10000	67	292.0	10.8	292.0	292.0	255.0	205.3	155.6	-	278.0	12.5	278.0	278.0	246.0	196.3	146.6	-
	62	282.2	10.7	282.2	282.2	282.2	232.5	182.8	133.1	269.2	12.4	269.2	269.2	269.2	219.6	169.9	120.2
	57	278.9	10.6	278.9	278.9	278.9	229.2	179.5	129.8	267.1	12.2	267.1	267.1	267.1	217.4	167.7	118.0

AIR ON EVAPORATOR COIL		TEMPERATURE OF AIR ON CONDENSER COIL															
		95°F									105°F						
		TOTAL CAP. <sup>1</sup> MBH	POWER INPUT <sup>2</sup> KW	SENSIBLE CAPACITY, MBH							TOTAL CAP. <sup>1</sup> MBH	POWER INPUT <sup>2</sup> KW	SENSIBLE CAPACITY, MBH				
				ENTERING DRY BULB, °F									ENTERING DRY BULB, °F				
CFM	WB °F	90	85	80	75	70	65	90	85	80	75	70	65				
6000	77	247.1	21.9	148.1	119.6	91.1	-	-	-	232.2	23.3	144.0	115.5	87.0	-	-	-
	72	235.0	21.5	184.6	156.1	127.6	99.0	-	-	221.1	22.9	180.0	151.5	123.0	94.5	-	-
	67	223.0	21.2	221.0	192.5	164.0	135.5	107.0	-	210.0	22.6	209.0	187.5	159.0	130.5	102.0	-
	62	216.5	20.9	216.5	216.5	193.0	164.5	136.0	107.5	205.4	22.2	205.4	205.4	183.0	154.5	126.0	97.5
	57	215.6	20.6	215.6	215.6	193.0	164.5	136.0	107.5	204.0	21.9	204.0	204.0	182.6	154.1	125.6	97.1
7000	77	257.0	20.8	185.3	134.3	100.6	-	-	-	241.6	22.3	184.7	132.6	96.0	-	-	-
	72	244.5	20.5	208.2	174.5	140.8	107.1	-	-	230.1	21.9	203.1	169.4	135.7	102.0	-	-
	67	236.0	20.1	231.0	214.7	182.0	147.3	113.6	-	218.5	21.6	218.0	206.2	175.5	141.8	108.1	-
	62	225.3	19.8	225.3	225.3	213.0	179.3	145.6	111.9	213.7	21.2	213.7	213.7	202.0	168.3	134.6	100.9
	57	224.3	19.6	224.3	224.3	213.0	179.3	145.6	111.9	212.2	21.0	212.2	212.2	201.6	167.9	134.2	100.5
8000	77	267.0	19.7	222.5	148.9	110.0	-	-	-	251.0	21.3	225.5	149.8	105.0	-	-	-
	72	254.0	19.4	231.8	192.9	154.0	115.1	-	-	239.0	20.9	226.3	187.4	148.5	109.6	-	-
	67	241.0	19.1	241.0	236.9	198.0	159.1	120.2	-	227.0	20.6	227.0	224.9	192.0	153.1	114.2	-
	62	234.0	18.8	234.0	234.0	233.0	194.1	155.2	116.4	222.0	20.2	222.0	222.0	221.0	182.1	143.2	104.4
	57	233.0	18.6	233.0	233.0	233.0	194.1	155.2	116.4	220.5	20.0	220.5	220.5	220.5	181.6	142.7	103.9
9000	72	266.1	16.9	255.0	213.4	169.2	124.9	-	-	251.1	18.4	244.7	208.0	163.7	119.4	-	-
	67	252.5	16.7	252.5	250.4	217.5	173.2	128.9	-	238.5	18.1	238.5	237.5	211.6	167.3	123.1	-
	62	245.2	16.4	245.2	245.2	244.7	200.4	156.1	111.8	233.3	17.8	233.3	233.3	232.8	188.5	144.2	99.9
	57	244.1	16.2	244.1	244.1	244.1	199.8	155.6	111.3	231.7	17.6	231.7	231.7	231.7	187.4	143.1	98.8
	72	278.2	14.4	278.2	234.0	184.3	134.7	-	-	263.2	16.0	263.2	228.5	178.9	129.2	-	-
10000	67	264.0	14.2	264.0	264.0	237.0	187.3	137.6	-	250.0	15.7	250.0	250.0	231.3	181.6	131.9	-
	62	256.3	14.0	256.3	256.3	256.3	206.7	157.0	107.3	244.5	15.4	244.5	244.5	244.5	194.8	145.1	95.5
	57	255.2	13.8	255.2	255.2	255.2	205.6	155.9	106.2	242.8	15.3	242.8	242.8	242.8	193.2	143.5	93.8

**TABLE 6: DH 240 COOLING CAPACITIES (20 TON) (CONTINUED)**

AIR ON EVAPORATOR COIL		TEMPERATURE OF AIR ON CONDENSER COIL							
		115°F							
		TOTAL CAP. <sup>1</sup> MBH	POWER INPUT <sup>2</sup> KW	SENSIBLE CAPACITY, MBH					
				ENTERING DRY BULB, °F					
CFM	WB °F			90	85	80	75	70	65
6000	77	217.3	24.8	139.8	111.3	82.8	-	-	-
	72	207.2	24.3	175.4	146.9	118.4	89.9	-	-
	67	197.0	23.9	197.0	182.5	154.0	125.5	97.0	-
	62	194.2	23.5	194.2	194.2	173.0	144.5	116.0	87.5
	57	192.4	23.2	192.4	192.4	172.2	143.7	115.2	86.7
7000	77	226.2	23.8	184.2	131.0	91.4	-	-	-
	72	215.6	23.4	198.1	164.4	130.7	97.0	-	-
	67	205.0	23.0	205.0	197.8	170.0	136.3	102.6	-
	62	202.1	22.5	202.1	202.1	191.0	157.3	123.6	89.9
	57	200.2	22.3	200.2	200.2	190.1	156.4	122.7	89.0
8000	77	235.0	22.8	228.5	150.8	100.0	-	-	-
	72	224.0	22.4	220.8	181.9	143.0	104.1	-	-
	67	213.0	22.0	213.0	213.0	186.0	147.1	108.2	-
	62	210.0	21.6	210.0	210.0	209.0	170.1	131.2	92.4
	57	208.0	21.4	208.0	208.0	208.0	169.1	130.2	91.4
9000	72	236.1	20.0	234.5	202.5	158.2	113.9	-	-
	67	224.5	19.6	224.5	224.5	205.8	161.5	117.2	-
	62	221.3	19.2	221.3	221.3	220.8	176.6	132.3	88.0
	57	219.2	19.1	219.2	219.2	219.2	175.0	130.7	86.4
10000	72	248.2	17.5	248.2	223.0	173.4	123.7	-	-
	67	236.0	17.2	236.0	236.0	225.5	175.8	126.1	-
	62	232.7	16.9	232.7	232.7	232.7	183.0	133.3	83.6
	57	230.5	16.7	230.5	230.5	230.5	180.8	131.1	81.4

1. These capacities are gross ratings. For net capacity, deduct the air blower motor, MBH = 3.415 x KW. Refer to the appropriate Blower Performance Table for the KW of the supply air blower motor.
2. These ratings include the condenser fan motors (Total 2.3 KW) and the compressor motors but not the supply air blower motor.

 Nominal Rating

**TABLE 7: DH 300 COOLING CAPACITIES (25 TON)**

AIR ON EVAPORATOR COIL		TEMPERATURE OF AIR ON CONDENSER COIL															
		75°F									85°F						
		TOTAL CAP. <sup>1</sup> MBH	POWER INPUT <sup>2</sup> KW	SENSIBLE CAPACITY, MBH							TOTAL CAP. <sup>1</sup> MBH	POWER INPUT <sup>2</sup> KW	SENSIBLE CAPACITY, MBH				
				ENTERING DRY BULB, °F									ENTERING DRY BULB, °F				
CFM	WB °F	90	85	80	75	70	65	90	85	80	75	70	65				
7500	77	371.3	19.7	191.8	156.2	120.6	-	-	-	348.9	21.5	185.5	149.8	114.2	-	-	-
	72	334.4	19.3	233.0	197.4	161.8	126.1	-	-	318.7	21.1	226.6	190.9	155.3	119.7	-	-
	67	297.6	18.8	274.2	238.6	203.0	167.3	131.7	-	288.4	20.8	267.7	232.0	196.4	160.8	125.1	-
	62	290.9	18.3	290.9	284.9	246.4	210.8	175.1	139.5	277.6	20.1	277.6	274.6	238.9	203.3	167.7	132.0
	57	281.0	18.2	281.0	281.0	261.8	226.1	190.5	154.9	272.4	20.1	272.4	272.4	249.6	214.0	178.3	142.7
8750	77	373.9	19.7	219.7	168.5	126.4	-	-	-	353.3	21.6	214.0	162.4	120.3	-	-	-
	72	336.8	19.3	253.8	211.7	169.6	127.5	-	-	322.7	21.3	247.8	205.7	163.6	121.5	-	-
	67	299.7	18.9	288.0	254.9	212.8	170.7	128.5	-	292.0	21.0	281.7	249.0	206.9	164.7	122.6	-
	62	293.0	18.3	293.0	290.0	258.3	216.2	174.1	132.0	281.1	20.3	281.1	279.6	251.7	209.5	167.4	125.3
	57	282.9	18.2	282.9	282.9	274.5	232.4	190.3	148.1	275.8	20.3	275.8	275.8	262.9	220.8	178.7	136.5
10000	77	376.6	19.8	247.6	180.9	132.3	-	-	-	357.7	21.8	242.4	175.0	126.4	-	-	-
	72	339.1	19.3	274.6	226.0	177.4	128.8	-	-	326.7	21.5	269.0	220.4	171.8	123.2	-	-
	67	301.7	18.9	301.7	271.2	222.6	174.0	125.4	-	295.7	21.1	295.7	265.9	217.3	168.7	120.1	-
	62	295.0	18.4	295.0	295.0	270.2	221.6	173.0	124.4	284.6	20.5	284.6	284.6	264.4	215.8	167.2	118.6
	57	284.9	18.3	284.9	284.9	287.2	238.6	190.0	141.4	279.3	20.4	279.3	279.3	276.2	227.6	179.0	130.4
11250	72	341.5	20.3	290.9	235.5	180.2	124.8	-	-	330.7	22.2	288.3	232.9	177.6	122.2	-	-
	67	303.7	19.8	303.7	281.3	226.0	170.6	115.3	-	299.3	21.8	299.3	279.9	224.5	169.2	113.8	-
	62	297.0	19.3	297.0	297.0	275.0	219.7	164.3	109.0	288.1	21.2	288.1	288.1	273.2	217.8	162.5	107.1
	57	286.8	19.2	286.8	286.8	287.9	232.6	177.2	121.9	282.7	21.1	282.7	282.7	281.2	225.8	170.5	115.1
	72	343.8	21.3	307.1	245.0	182.9	120.8	-	-	334.8	22.9	307.5	245.4	183.3	121.2	-	-
12500	67	305.7	20.8	305.7	291.5	229.4	167.3	105.2	-	303.0	22.6	303.0	293.9	231.8	169.7	107.6	-
	62	299.1	20.2	299.1	299.1	279.8	217.7	155.6	93.5	291.6	21.8	291.6	291.6	282.0	219.9	157.8	95.7
	57	288.7	20.1	288.7	288.7	288.7	226.6	164.5	102.4	286.1	21.8	286.1	286.1	286.1	224.0	161.9	99.8

AIR ON EVAPORATOR COIL		TEMPERATURE OF AIR ON CONDENSER COIL															
		95°F									105°F						
		TOTAL CAP. <sup>1</sup> MBH	POWER INPUT <sup>2</sup> KW	SENSIBLE CAPACITY, MBH							TOTAL CAP. <sup>1</sup> MBH	POWER INPUT <sup>2</sup> KW	SENSIBLE CAPACITY, MBH				
				ENTERING DRY BULB, °F									ENTERING DRY BULB, °F				
CFM	WB °F	90	85	80	75	70	65	90	85	80	75	70	65				
7500	77	326.6	23.2	179.1	143.5	107.9	-	-	-	314.3	26.2	163.3	127.7	92.0	-	-	-
	72	302.9	23.0	220.1	184.5	148.8	113.2	-	-	288.7	25.8	209.2	173.5	137.9	102.2	-	-
	67	279.2	22.8	261.1	225.5	189.8	154.2	118.5	-	263.1	25.3	254.1	219.4	183.7	148.1	112.5	-
	62	264.2	22.0	264.2	264.2	231.5	195.8	160.2	124.6	253.6	24.5	253.6	253.6	225.7	190.1	154.5	118.8
	57	263.7	22.0	263.7	263.7	237.4	201.8	166.1	130.5	251.0	24.6	251.0	251.0	222.7	187.1	151.4	115.8
8750	77	332.8	23.5	208.2	156.3	114.2	-	-	-	319.5	26.4	197.7	139.8	97.6	-	-	-
	72	308.6	23.3	241.8	199.7	157.5	115.4	-	-	293.5	25.9	230.6	188.5	146.3	104.2	-	-
	67	284.4	23.1	275.4	243.0	200.9	158.8	116.7	-	267.5	25.4	263.0	237.2	195.0	152.9	110.8	-
	62	269.2	22.3	269.2	269.2	245.0	202.9	160.8	118.7	257.8	24.7	257.8	257.8	239.6	197.5	155.4	113.3
	57	268.7	22.3	268.7	268.7	251.3	209.2	167.1	124.9	255.2	24.8	255.2	255.2	236.4	194.2	152.1	110.0
10000	77	338.9	23.8	237.3	169.1	120.5	-	-	-	324.6	26.6	232.2	151.9	103.3	-	-	-
	72	314.3	23.6	263.5	214.9	166.3	117.7	-	-	298.2	26.1	252.0	203.4	154.8	106.2	-	-
	67	289.7	23.4	289.7	260.6	212.0	163.4	114.8	-	271.8	25.6	271.8	254.9	206.3	157.7	109.1	-
	62	274.2	22.6	274.2	274.2	258.6	210.0	161.4	112.8	261.9	24.9	261.9	261.9	253.5	204.9	156.3	107.7
	57	273.7	22.6	273.7	273.7	265.2	216.6	168.0	119.4	259.3	24.9	259.3	259.3	250.0	201.4	152.8	104.2
11250	72	320.0	24.1	285.6	230.3	174.9	119.6	-	-	303.0	26.5	271.3	215.9	160.6	105.2	-	-
	67	294.9	23.9	294.9	278.4	223.1	167.7	112.4	-	276.2	26.0	276.2	266.7	213.9	158.5	103.2	-
	62	279.2	23.0	279.2	279.2	271.4	216.0	160.7	105.3	266.1	25.2	266.1	266.1	261.9	206.5	151.2	95.8
	57	278.6	23.0	278.6	278.6	274.4	219.0	163.7	108.3	263.4	25.3	263.4	263.4	257.0	201.6	146.3	90.9
	72	325.7	24.6	307.8	245.7	183.6	121.5	-	-	307.8	26.8	290.5	228.4	166.3	104.2	-	-
12500	67	300.2	24.3	300.2	296.2	234.1	172.0	109.9	-	280.5	26.3	280.5	278.5	221.4	159.3	97.2	-
	62	284.1	23.5	284.1	284.1	284.1	222.0	159.9	97.8	270.3	25.6	270.3	270.3	270.3	208.2	146.1	84.0
	57	283.6	23.5	283.6	283.6	283.6	221.5	159.4	97.3	267.6	25.6	267.6	267.6	263.9	201.8	139.7	77.6



**TABLE 7: DH 300 COOLING CAPACITIES (25 TON) (CONTINUED)**

AIR ON EVAPORATOR COIL		TEMPERATURE OF AIR ON CONDENSER COIL							
		115°F							
		TOTAL CAP. <sup>1</sup> MBH	POWER INPUT <sup>2</sup> KW	SENSIBLE CAPACITY, MBH					
				ENTERING DRY BULB, °F					
CFM	WB °F			90	85	80	75	70	65
7500	77	302.0	29.3	147.5	111.8	76.2	-	-	-
	72	274.5	28.5	198.2	162.6	126.9	91.3	-	-
	67	247.1	27.7	247.1	213.3	177.7	142.0	106.4	-
	62	242.9	27.1	242.9	242.9	220.0	184.3	148.7	113.1
	57	238.3	27.2	238.3	238.3	208.0	172.3	136.7	101.1
8750	77	306.2	29.3	187.3	123.2	81.1	-	-	-
	72	278.4	28.5	219.4	177.3	135.1	93.0	-	-
	67	250.5	27.8	250.5	231.3	189.2	147.0	104.9	-
	62	246.3	27.1	246.3	246.3	234.2	192.1	150.0	107.8
	57	241.6	27.3	241.6	241.6	221.4	179.3	137.2	95.1
10000	77	310.4	29.4	227.1	134.6	86.0	-	-	-
	72	282.2	28.6	240.5	191.9	143.3	94.7	-	-
	67	254.0	27.8	254.0	249.2	200.6	152.0	103.4	-
	62	249.7	27.2	249.7	249.7	248.4	199.8	151.2	102.6
	57	244.9	27.3	244.9	244.9	234.9	186.3	137.7	89.1
11250	72	286.0	28.9	256.9	201.6	146.2	90.9	-	-
	67	257.4	28.1	257.4	255.1	204.7	149.3	94.0	-
	62	253.1	27.4	253.1	253.1	252.4	197.1	141.7	86.4
	57	248.2	27.6	248.2	248.2	239.6	184.2	128.9	73.5
12500	72	289.8	29.1	273.3	211.2	149.1	87.0	-	-
	67	260.9	28.3	260.9	260.9	208.7	146.6	84.5	-
	62	256.4	27.7	256.4	256.4	256.4	194.3	132.2	70.1
	57	251.5	27.8	251.5	251.5	244.3	182.2	120.1	58.0

1. These capacities are gross ratings. For net capacity, deduct the air blower motor, MBH = 3.415 x KW. Refer to the appropriate Blower Performance Table for the KW of the supply air blower motor.
2. These ratings include the condenser fan motors (Total 2.1 KW) and the compressor motors but not the supply air blower motor.

 Nominal Rating

## CFM, STATIC PRESSURE, AND POWER - ALTI-TUDE AND TEMPERATURE CORRECTIONS

The information below should be used to assist in application of product when being applied at altitudes at or exceeding 1000 feet above sea level.

The air flow rates listed in the standard blower performance tables are based on standard air at sea level. As the altitude or temperature increases, the density of air decreases. In

order to use the indoor blower tables for high altitude applications, certain corrections are necessary.

A centrifugal fan is a "constant volume" device. This means that, if the rpm remains constant, the CFM delivered is the same regardless of the density of the air. However, since the air at high altitude is less dense, less static pressure will be generated and less power will be required than a similar application at sea level. Air density correction factors are shown in Table 8 and Figure 2.

**TABLE 8: ALTITUDE CORRECTION FACTORS**

AIR TEMP	ALTITUDE (FEET)										
	0	1000	2000	3000	4000	5000	6000	7000	8000	9000	10000
40	1.060	1.022	0.986	0.950	0.916	0.882	0.849	0.818	0.788	0.758	0.729
50	1.039	1.002	0.966	0.931	0.898	0.864	0.832	0.802	0.772	0.743	0.715
60	1.019	0.982	0.948	0.913	0.880	0.848	0.816	0.787	0.757	0.729	0.701
70	1.000	0.964	0.930	0.896	0.864	0.832	0.801	0.772	0.743	0.715	0.688
80	0.982	0.947	0.913	0.880	0.848	0.817	0.787	0.758	0.730	0.702	0.676
90	0.964	0.929	0.897	0.864	0.833	0.802	0.772	0.744	0.716	0.689	0.663
100	0.946	0.912	0.880	0.848	0.817	0.787	0.758	0.730	0.703	0.676	0.651

The examples below will assist in determining the airflow performance of the product at altitude.

**Example 1:** What are the corrected CFM, static pressure, and BHP at an elevation of 5,000 ft. if the blower performance data is 6,000 CFM, 1.5 IWC and 4.0 BHP?

**Solution:** At an elevation of 5,000 ft the indoor blower will still deliver 6,000 CFM if the rpm is unchanged. However, Table 8 must be used to determine the static pressure and BHP. Since no temperature data is given, we will assume an air temperature of 70°F. Table 8 shows the correction factor to be 0.832.

$$\text{Corrected static pressure} = 1.5 \times 0.832 = 1.248 \text{ IWC}$$

$$\text{Corrected BHP} = 4.0 \times 0.832 = 3.328$$

**Example 2:** A system, located at 5,000 feet of elevation, is to deliver 6,000 CFM at a static pressure of 1.5". Use the unit

blower tables to select the blower speed and the BHP requirement.

**Solution:** As in the example above, no temperature information is given so 70°F is assumed.

The 1.5" static pressure given is at an elevation of 5,000 ft. The first step is to convert this static pressure to equivalent sea level conditions.

$$\text{Sea level static pressure} = 1.5 / .832 = 1.80"$$

Enter the blower table at 6000 sCFM and static pressure of 1.8". The rpm listed will be the same rpm needed at 5,000 ft.

Suppose that the corresponding BHP listed in the table is 3.2. This value must be corrected for elevation.

$$\text{BHP at 5,000 ft} = 3.2 \times .832 = 2.66$$

# Altitude/Temperature Conversion Factor

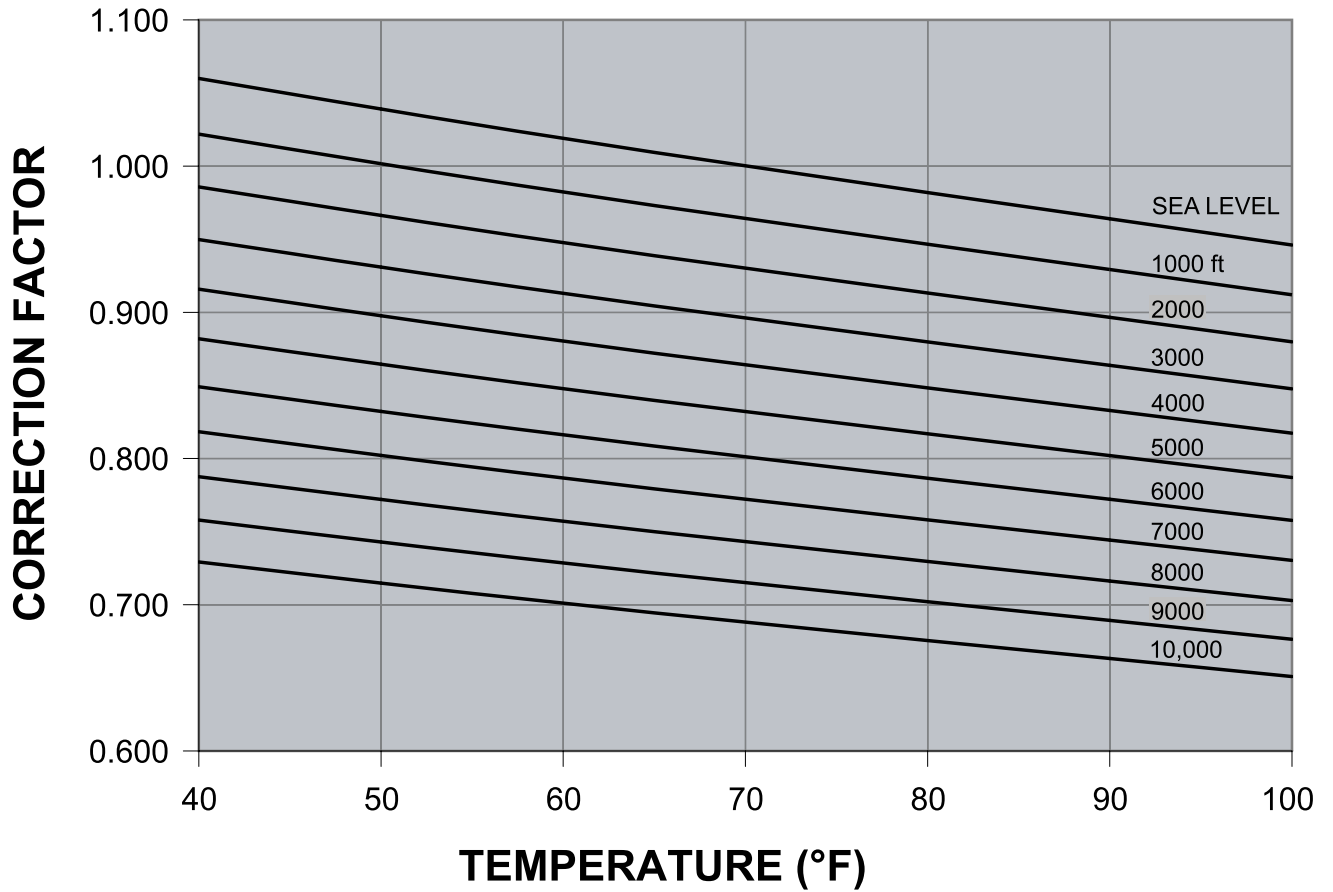

FIGURE 2 - ALTITUDE/TEMPERATURE CONVERSION FACTOR

**TABLE 9: SUPPLY AIR BLOWER PERFORMANCE (15 TON) - COOLING ONLY  
180 MBH - BOTTOM DUCT CONNECTIONS**

BLOWER SPEED, (RPM)	MOTOR PULLEY (TURNS OPEN)*	CFM														
		4500			5250			6000			6750			7200		
		ESP	BHP	KW	ESP	BHP	KW	ESP	BHP	KW	ESP	BHP	KW	ESP	BHP	KW
<b>208 VOLT AND STANDARD DRIVE</b>																
850	6.0**	0.9	2.4	2.2	0.7	3.0	2.7	0.5	3.2	2.9	-	-	-	-	-	-
870	5.5	1.0	2.5	2.3	0.8	3.1	2.8	0.6	3.5	3.1	0.2	4.1	3.7	-	-	-
915	4.5	1.1	2.6	2.4	0.9	3.4	3.0	0.7	3.7	3.3	0.3	4.4	3.9	0.2	4.5	4.0
965	3.5	1.2	2.9	2.6	1.0	3.6	3.2	0.8	4.0	3.6	0.5	4.7	4.2	0.4	4.9	4.4
980	3.0	1.3	3.0	2.7	1.1	3.7	3.3	0.9	4.1	3.7	0.6	4.8	4.3	0.5	5.1	4.6
1010	2.0	1.4	3.1	2.8	1.2	3.8	3.4	1.0	4.2	3.8	0.7	5.0	4.5	0.6	5.4	4.8
1040	1.0	1.5	3.2	2.9	1.3	3.9	3.5	1.1	4.5	4.0	0.9	5.2	4.7	0.7	5.7	5.1
<b>208 VOLT AND HIGH STATIC DRIVE</b>																
965	6.0	1.2	2.9	2.6	1.0	3.6	3.2	0.8	4.0	3.6	0.5	4.7	4.2	0.4	5.0	4.4
980	5.5	1.3	3.0	2.7	1.1	3.7	3.3	0.9	4.1	3.7	0.6	4.8	4.3	0.5	5.1	4.6
1025	4.5	1.5	3.2	2.9	1.3	3.9	3.5	1.1	4.5	4.0	0.8	5.1	4.6	0.7	5.6	5.0
1065	3.5	1.6	3.4	3.0	1.4	4.0	3.6	1.2	4.7	4.2	1.0	5.5	4.9	-	-	-
1095	3.0	1.7	3.5	3.1	1.5	4.2	3.8	1.3	4.9	4.4	1.2	5.7	5.1	-	-	-
1130	2.0	1.9	3.7	3.3	1.7	4.5	4.0	1.5	5.1	4.6	-	-	-	-	-	-
1170	1.0	2.1	3.9	3.5	2.0	4.7	4.2	1.8	5.5	4.9	-	-	-	-	-	-
<b>230/460/575 VOLT AND STANDARD DRIVE</b>																
870	6.0**	1.0	2.4	2.2	0.8	3.1	2.8	0.6	3.5	3.1	0.2	4.1	3.7	-	-	-
915	5.0	1.1	2.6	2.4	0.9	3.3	3.0	0.7	3.7	3.3	0.3	4.4	3.9	0.2	4.5	4.0
965	4.0	1.2	2.9	2.6	1.0	3.6	3.2	0.8	4.0	3.6	0.5	4.7	4.2	0.4	5.0	4.4
980	3.5	1.3	3.0	2.7	1.1	3.7	3.3	0.9	4.1	3.7	0.6	4.8	4.3	0.5	5.1	4.6
1040	2.0	1.5	3.2	2.9	1.3	3.9	3.5	1.1	4.5	4.0	0.9	5.3	4.7	0.7	5.7	5.1
1065	1.0	1.6	3.3	3.0	1.4	4.0	3.6	1.2	4.7	4.2	1.0	5.5	4.9	-	-	-
<b>230/460/575 VOLT AND HIGH STATIC DRIVE</b>																
980	6.0	1.3	2.9	2.6	1.1	3.7	3.3	0.9	4.1	3.7	0.6	4.8	4.3	0.5	5.1	4.6
1040	4.5	1.5	3.2	2.9	1.3	3.9	3.5	1.1	4.5	4.0	0.9	5.3	4.7	0.7	5.7	5.1
1065	4.0	1.6	3.4	3.0	1.4	4.0	3.6	1.2	4.7	4.2	1.0	5.5	4.9	-	-	-
1095	3.5	1.7	3.5	3.1	1.5	4.2	3.8	1.3	4.9	4.4	1.2	5.7	5.1	-	-	-
1130	2.5	1.9	3.7	3.3	1.7	4.5	4.0	1.5	5.1	4.6	-	-	-	-	-	-
1170	1.5	2.1	3.9	3.5	2.0	4.7	4.2	1.8	5.5	4.9	-	-	-	-	-	-
1190	1.0	2.2	4.0	3.6	2.1	4.8	4.3	2.0	5.7	5.1	-	-	-	-	-	-

- NOTES: 1. Blower performance includes fixed outdoor air, 2" T/A filters, a dry evaporator coil and no electric heat.  
2. Refer to Table 11 for additional static resistances.  
ESP = External Static Pressure available for the supply and return air duct system. All internal unit resistances have been deducted from the total static pressure of the blower.  
\* Do NOT close the pulley below 1 turn open.  
\*\* Factory setting.

**TABLE 10: SUPPLY AIR BLOWER PERFORMANCE (17.5 TON) - COOLING ONLY  
210 MBH - BOTTOM DUCT CONNECTIONS**

BLOWER SPEED, (RPM)	MOTOR PULLEY (TURNS OPEN)*	CFM											
		6000			7000			8000			9000		
		ESP	BHP	KW	ESP	BHP	KW	ESP	BHP	KW	ESP	BHP	KW
<b>208 VOLT AND STANDARD DRIVE</b>													
870	6.0**	0.4	2.1	1.8	0.1	2.3	2.0	-	-	-	-	-	-
900	5.0	0.8	3.2	2.7	0.5	3.5	2.9	0.2	3.8	3.2	-	-	-
930	4.0	1.1	4.1	3.4	0.9	4.5	3.8	0.6	4.9	4.1	0.1	5.1	4.3
950	3.0	1.3	4.6	3.9	1.1	5.1	4.3	0.8	5.5	4.6	0.4	5.9	5.0
980	2.0	1.6	5.3	4.5	1.4	5.8	4.9	1.2	6.3	5.3	0.7	6.9	5.8
1015	1.0	1.9	5.9	5.0	1.7	6.5	5.5	1.5	7.0	5.9	1.0	7.7	6.5
<b>208 VOLT AND HIGH STATIC DRIVE</b>													
950	6.0	1.3	4.6	3.9	1.1	5.1	4.3	0.8	5.5	4.6	0.4	5.9	5.0
980	5.0	1.6	5.3	4.5	1.4	5.8	4.9	1.2	6.3	5.3	0.7	6.9	5.8
1010	4.0	1.8	5.8	4.9	1.7	6.3	5.3	1.5	6.9	5.8	1.0	7.5	6.3
1020	3.5	1.9	6.1	5.1	1.8	6.5	5.5	1.6	7.1	6.0	1.1	7.8	6.6
1035	3.0	2.0	6.2	5.2	1.9	6.8	5.7	1.7	7.4	6.2	1.2	8.1	6.8
1050	2.5	2.1	6.4	5.4	2.0	7.0	5.9	1.8	7.6	6.4	1.3	8.3	7.0
1075	2.0	2.3	6.6	5.5	2.1	7.2	6.0	1.9	7.8	6.6	1.5	8.6	7.2
1100	1.0	2.4	6.7	5.6	2.2	7.3	6.1	2.1	7.9	6.7	-	-	-
<b>230/460/575 VOLT AND STANDARD DRIVE</b>													
870	6.0**	0.4	2.1	1.8	0.1	2.3	2.0	-	-	-	-	-	-
900	5.0	0.8	3.2	2.7	0.5	3.5	2.9	0.2	3.8	3.2	-	-	-
930	4.0	1.1	4.1	3.4	0.9	4.5	3.8	0.6	4.9	4.1	0.1	5.1	4.3
950	3.5	1.3	4.6	3.9	1.1	5.1	4.3	0.8	5.5	4.6	0.4	5.9	5.0
980	2.5	1.6	5.3	4.5	1.4	5.8	4.9	1.2	6.3	5.3	0.7	6.9	5.8
1015	1.5	1.9	5.9	5.0	1.7	6.5	5.5	1.5	7.0	5.9	1.0	7.7	6.5
1025	1.0	2.0	6.1	5.1	1.8	6.6	5.6	1.6	7.3	6.1	1.1	7.9	6.7
<b>230/460/575 VOLT AND HIGH STATIC DRIVE</b>													
950	6.0	1.3	4.6	3.9	1.1	5.1	4.3	0.8	5.5	4.6	0.4	5.9	5.0
980	5.0	1.6	5.3	4.5	1.4	5.8	4.9	1.2	6.3	5.3	0.7	6.9	5.8
1015	4.0	1.9	5.9	5.0	1.7	6.5	5.5	1.5	7.0	5.9	1.0	7.7	6.5
1035	3.5	2.0	6.2	5.2	1.9	6.8	5.7	1.7	7.4	6.2	1.2	8.1	6.8
1050	3.0	2.1	6.4	5.4	2.0	7.0	5.9	1.8	7.6	6.4	1.3	8.3	7.0
1080	2.0	2.3	6.6	5.5	2.1	7.2	6.0	1.9	7.8	6.6	1.5	8.6	7.2
1100	1.5	2.4	6.7	5.6	2.2	7.3	6.1	2.1	7.9	6.7	-	-	-
1120	1.0	2.5	6.8	5.7	2.3	7.4	6.2	2.2	8.1	6.8	-	-	-

NOTES: 1. Blower performance includes fixed outdoor air, 2" T/A filters, a dry evaporator coil and no electric heat.

2. Refer to Table 13 for additional static resistances.

ESP = External Static Pressure available for the supply and return air duct system. All internal unit resistances have been deducted from the total static pressure of the blower.

\* Do **NOT** close the pulley below 1 turn open.

\*\* Factory setting.

**TABLE 11: SUPPLY AIR BLOWER PERFORMANCE (20 TON) - COOLING ONLY  
240 MBH - BOTTOM DUCT CONNECTIONS**

BLOWER SPEED, (RPM)	MOTOR PULLEY (TURNS OPEN)*	CFM														
		6000			7000			8000			9000			9400		
		ESP	BHP	KW	ESP	BHP	KW	ESP	BHP	KW	ESP	BHP	KW	ESP	BHP	KW
<b>208 VOLT AND STANDARD DRIVE</b>																
870	6.0**	0.4	2.1	1.8	0.1	2.3	2.0	-	-	-	-	-	-	-	-	-
900	5.0	0.8	3.2	2.7	0.5	3.5	2.9	0.2	3.8	3.2	-	-	-	-	-	-
930	4.0	1.1	4.1	3.4	0.9	4.5	3.8	0.6	4.9	4.1	0.1	5.1	4.3	-	-	-
950	3.0	1.3	4.6	3.9	1.1	5.1	4.3	0.8	5.5	4.6	0.4	5.9	5.0	-	-	-
980	2.0	1.6	5.3	4.5	1.4	5.8	4.9	1.2	6.3	5.3	0.7	6.9	5.8	0.2	7.3	6.1
1015	1.0	1.9	5.9	5.0	1.7	6.5	5.5	1.5	7.0	5.9	1.0	7.7	6.5	0.6	8.2	6.9
<b>208 VOLT AND HIGH STATIC DRIVE</b>																
950	6.0	1.3	4.6	3.9	1.1	5.1	4.3	0.8	5.5	4.6	0.4	5.9	5.0	-	-	-
980	5.0	1.6	5.3	4.5	1.4	5.8	4.9	1.2	6.3	5.3	0.7	6.9	5.8	0.2	7.3	6.1
1010	4.0	1.8	5.8	4.9	1.7	6.3	5.3	1.5	6.9	5.8	1.0	7.5	6.3	0.5	7.9	6.7
1020	3.5	1.9	6.1	5.1	1.8	6.5	5.5	1.6	7.1	6.0	1.1	7.8	6.6	0.6	8.3	7.0
1035	3.0	2.0	6.2	5.2	1.9	6.8	5.7	1.7	7.4	6.2	1.2	8.1	6.8	0.7	8.6	7.3
1050	2.5	2.1	6.4	5.4	2.0	7.0	5.9	1.8	7.6	6.4	1.3	8.3	7.0	-	-	-
1075	2.0	2.3	6.6	5.5	2.1	7.2	6.0	1.9	7.8	6.6	1.5	8.6	7.2	-	-	-
1100	1.0	2.4	6.7	5.6	2.2	7.3	6.1	2.1	7.9	6.7	-	-	-	-	-	-
<b>230/460/575 VOLT AND STANDARD DRIVE</b>																
870	6.0**	0.4	2.1	1.8	0.1	2.3	2.0	-	-	-	-	-	-	-	-	-
900	5.0	0.8	3.2	2.7	0.5	3.5	2.9	0.2	3.8	3.2	-	-	-	-	-	-
930	4.0	1.1	4.1	3.4	0.9	4.5	3.8	0.6	4.9	4.1	0.1	5.1	4.3	-	-	-
950	3.5	1.3	4.6	3.9	1.1	5.1	4.3	0.8	5.5	4.6	0.4	5.9	5.0	-	-	-
980	2.5	1.6	5.3	4.5	1.4	5.8	4.9	1.2	6.3	5.3	0.7	6.9	5.8	0.2	7.3	6.1
1015	1.5	1.9	5.9	5.0	1.7	6.5	5.5	1.5	7.0	5.9	1.0	7.7	6.5	0.6	8.2	6.9
1025	1.0	2.0	6.1	5.1	1.8	6.6	5.6	1.6	7.3	6.1	1.1	7.9	6.7	0.7	8.6	7.3
<b>230/460/575 VOLT AND HIGH STATIC DRIVE</b>																
950	6.0	1.3	4.6	3.9	1.1	5.1	4.3	0.8	5.5	4.6	0.4	5.9	5.0	-	-	-
980	5.0	1.6	5.3	4.5	1.4	5.8	4.9	1.2	6.3	5.3	0.7	6.9	5.8	0.2	7.3	6.1
1015	4.0	1.9	5.9	5.0	1.7	6.5	5.5	1.5	7.0	5.9	1.0	7.7	6.5	0.6	8.2	6.9
1035	3.5	2.0	6.2	5.2	1.9	6.8	5.7	1.7	7.4	6.2	1.2	8.1	6.8	0.7	8.6	7.3
1050	3.0	2.1	6.4	5.4	2.0	7.0	5.9	1.8	7.6	6.4	1.3	8.3	7.0	-	-	-
1080	2.0	2.3	6.6	5.5	2.1	7.2	6.0	1.9	7.8	6.6	1.5	8.6	7.2	-	-	-
1100	1.5	2.4	6.7	5.6	2.2	7.3	6.1	2.1	7.9	6.7	-	-	-	-	-	-
1120	1.0	2.5	6.8	5.7	2.3	7.4	6.2	2.2	8.1	6.8	-	-	-	-	-	-

- NOTES: 1. Blower performance includes fixed outdoor air, 2" T/A filters, a dry evaporator coil and no electric heat.  
2. Refer to Table 11 for additional static resistances.  
ESP = External Static Pressure available for the supply and return air duct system. All internal unit resistances have been deducted from the total static pressure of the blower.  
\* Do **NOT** close the pulley below 1 turn open.  
\*\* Factory setting.

**TABLE 12: SUPPLY AIR BLOWER PERFORMANCE (15 TON) - GAS HEAT  
180 MBH - BOTTOM DUCT CONNECTIONS**

BLOWER SPEED, (RPM)	MOTOR PULLEY (TURNS OPEN)*	CFM														
		4500			5250			6000			6750			7200		
		ESP	BHP	KW	ESP	BHP	KW	ESP	BHP	KW	ESP	BHP	KW	ESP	BHP	KW
<b>208 VOLT AND STANDARD DRIVE</b>																
850	6.0**	0.9	2.4	2.1	0.6	2.9	2.6	0.3	3.4	3.0	-	-	-	-	-	-
870	5.5	1.0	2.5	2.2	0.7	3.0	2.7	0.4	3.5	3.1	-	-	-	-	-	-
915	4.5	1.1	2.6	2.4	0.8	3.1	2.8	0.5	3.6	3.2	0.2	4.1	3.7	-	-	-
965	3.5	1.2	2.7	2.5	0.9	3.2	2.9	0.6	3.7	3.3	0.4	4.4	3.0	0.2	5.0	4.5
980	3.0	1.3	2.9	2.6	1.0	3.4	3.0	0.7	3.8	3.4	0.5	4.5	4.0	0.3	5.1	4.6
1010	2.0	1.4	3.0	2.7	1.1	3.6	3.2	0.8	4.0	3.6	0.6	4.7	4.2	0.4	5.4	4.8
1040	1.0	1.6	3.2	2.9	1.3	3.8	3.4	1.0	4.4	3.9	0.8	5.0	4.5	0.6	5.6	5.0
<b>208 VOLT AND HIGH STATIC DRIVE</b>																
965	6.0	1.2	2.7	2.5	0.9	3.2	2.9	0.6	3.7	3.3	0.4	4.4	3.9	0.2	5.0	4.5
980	5.5	1.3	2.9	2.6	1.0	3.4	3.0	0.7	3.8	3.4	0.5	4.5	4.0	0.3	5.1	4.6
1025	4.5	1.4	3.1	2.8	1.2	3.6	3.2	0.9	4.1	3.7	0.7	4.8	4.3	0.4	5.5	4.9
1065	3.5	1.6	3.4	3.0	1.4	3.9	3.5	1.1	4.5	4.0	0.9	5.1	4.6	-	-	-
1125	2.0	1.9	3.6	3.2	1.7	4.4	3.9	1.4	5.0	4.5	1.2	5.8	5.2	-	-	-
1170	1.0	2.1	3.9	3.5	1.9	4.7	4.2	1.6	5.5	4.9	-	-	-	-	-	-
<b>230/460/575 VOLT AND STANDARD DRIVE</b>																
870	6.0**	1.0	2.5	2.2	0.7	3.0	2.7	0.4	3.5	3.1	-	-	-	-	-	-
915	5.0	1.1	2.6	2.4	0.8	3.1	2.8	0.5	3.6	3.2	0.2	4.1	3.7	-	-	-
965	4.0	1.2	2.7	2.5	0.9	3.2	2.9	0.6	3.7	3.3	0.4	4.4	3.9	0.2	5.0	4.5
980	3.5	1.3	2.9	2.6	1.0	3.4	3.0	0.7	3.8	3.4	0.5	4.5	4.0	0.3	5.1	4.6
1015	2.5	1.4	3.0	2.7	1.1	3.6	3.2	0.8	4.0	3.6	0.6	4.7	4.2	0.4	5.4	4.8
1050	1.5	1.5	3.1	2.8	1.2	3.7	3.3	0.9	4.2	3.8	0.7	4.9	4.4	0.5	5.7	5.1
1065	1.0	1.6	3.4	3.0	1.4	3.9	3.5	1.1	4.5	4.0	0.9	5.1	4.6	-	-	-
<b>230/460/575 VOLT AND HIGH STATIC DRIVE</b>																
980	6.0	1.3	2.9	2.6	1.0	3.4	3.0	0.7	3.8	3.4	0.5	4.5	4.0	0.3	5.1	4.6
1045	4.5	1.6	3.2	2.9	1.3	3.8	3.4	1.0	4.4	3.9	0.8	5.0	4.5	0.6	5.6	5.0
1065	4.0	1.7	3.4	3.0	1.4	3.9	3.5	1.1	4.5	4.0	0.9	5.1	4.6	-	-	-
1125	2.5	1.9	3.6	3.2	1.7	4.4	3.9	1.4	5.0	4.5	1.2	5.8	5.2	-	-	-
1170	1.5	2.1	3.9	3.5	1.8	4.7	4.2	1.6	5.5	4.9	-	-	-	-	-	-
1190	1.0	2.2	4.0	3.6	1.9	4.8	4.3	1.7	5.6	5.0	-	-	-	-	-	-

NOTES: 1. Blower performance includes a gas-fired heat exchanger, fixed outdoor air, two-inch T/A filters and a dry evaporator coil.  
 2. Refer to the additional Static Resistances table.  
 ESP = External Static Pressure available for the supply and return air duct system. All internal unit resistances have been deducted from the total static pressure of the blower.  
 \* Do NOT close the pulley below 1 turn open.  
 \*\* Factory setting.

**TABLE 13: SUPPLY AIR BLOWER PERFORMANCE (17.5 TON) - GAS HEAT  
210 MBH - BOTTOM DUCT CONNECTIONS**

BLOWER SPEED, (RPM)	MOTOR PULLEY (TURNS OPEN)*	CFM											
		6000			7000			8000			9000		
		ESP	BHP	KW	ESP	BHP	KW	ESP	BHP	KW	ESP	BHP	KW
<b>208 VOLT AND STANDARD DRIVE</b>													
870	6.0**	1.3	3.6	3.0	0.7	4.3	3.7	0.2	5.1	4.3	-	-	-
900	5.0	1.4	3.8	3.2	0.9	4.7	4.0	0.4	5.6	4.7	-	-	-
930	4.0	1.6	4.1	3.4	1.1	5.0	4.2	0.6	5.9	5.0	0.1	6.7	5.7
950	3.0	1.7	4.2	3.6	1.3	5.1	4.3	0.8	6.0	5.1	0.2	6.9	5.8
980	2.0	1.9	4.5	3.8	1.5	5.4	4.5	1.0	6.3	5.3	0.4	7.2	6.1
995	1.5	2.1	4.6	3.9	1.6	5.5	4.7	1.1	6.4	5.4	0.5	7.5	6.3
1015	1.0	2.2	4.8	4.0	1.7	5.7	4.8	1.2	6.6	5.6	0.7	7.8	6.6
<b>208 VOLT AND HIGH STATIC DRIVE</b>													
950	6.0	1.7	4.2	3.6	1.3	5.1	4.3	0.8	6.0	5.1	0.2	6.9	5.8
980	5.0	1.9	4.5	3.8	1.5	5.4	4.5	1.0	6.3	5.3	0.4	7.2	6.1
995	4.5	2.1	4.5	3.9	1.6	5.5	4.7	1.1	6.4	5.4	0.5	7.5	6.3
1025	3.5	2.3	4.9	4.1	1.8	5.8	4.9	1.3	6.7	5.7	0.7	8.0	6.7
1050	2.5	2.5	5.1	4.3	2.0	6.1	5.1	1.4	7.1	6.0	0.9	8.4	7.0
1065	2.0	2.6	5.3	4.4	2.1	6.3	5.3	1.5	7.3	6.2	1.0	8.6	7.2
1100	1.0	2.9	5.6	4.7	2.3	6.8	5.7	1.8	7.9	6.6	-	-	-
<b>230/460/575 VOLT AND STANDARD DRIVE</b>													
870	6.0**	1.3	3.6	3.0	0.7	4.3	3.7	0.2	5.1	4.3	-	-	-
900	5.0	1.4	3.8	3.2	0.9	4.7	4.0	0.4	5.6	4.7	-	-	-
930	4.0	1.6	4.1	3.4	1.1	5.0	4.2	0.6	5.9	5.0	0.1	6.7	5.7
950	3.5	1.7	4.2	3.6	1.3	5.1	4.3	0.8	6.0	5.1	0.2	6.9	5.8
965	2.5	1.9	4.5	3.8	1.5	5.4	4.5	1.0	6.3	5.3	0.4	7.2	6.1
995	2.0	2.1	4.6	3.9	1.6	5.5	4.7	1.1	6.4	5.4	0.5	7.5	6.3
1015	1.5	2.2	4.8	4.0	1.7	5.7	4.8	1.2	6.6	5.6	0.6	7.8	6.6
1025	1.0	2.3	4.9	4.1	1.8	5.8	4.9	1.3	6.7	5.7	0.7	8.0	6.7
<b>230/460/575 VOLT AND HIGH STATIC DRIVE</b>													
950	6.0	1.7	4.2	3.6	1.3	5.1	4.3	0.8	6.0	5.1	0.2	6.9	5.8
980	5.0	1.9	4.5	3.8	1.5	5.4	4.5	1.0	6.3	5.3	0.4	7.2	6.1
995	4.5	2.1	4.6	3.9	1.6	5.5	4.7	1.1	6.4	5.4	0.5	7.5	6.3
1015	4.0	2.2	4.8	4.0	1.7	5.7	4.8	1.2	6.6	5.6	0.6	7.8	6.6
1025	3.5	2.3	4.9	4.1	1.8	5.8	4.9	1.3	6.7	5.7	0.7	8.0	6.7
1050	3.0	2.5	5.1	4.3	2.0	6.1	5.1	1.4	7.1	6.0	0.9	8.4	7.0
1065	2.5	2.6	5.3	4.4	2.1	6.3	5.3	1.5	7.3	6.2	1.0	8.6	7.2
1100	1.5	2.9	5.6	4.7	2.3	6.8	4.7	1.8	7.9	6.6	-	-	-
1120	1.0	3.1	5.8	4.9	2.5	7.0	5.9	1.9	8.3	6.9	-	-	-

- NOTES: 1. Blower performance includes a gas-fired heat exchanger, fixed outdoor air, two-inch T/A filters and a dry evaporator coil.  
2. Refer to the additional Static Resistances table.  
ESP = External Static Pressure available for the supply and return air duct system. All internal unit resistances have been deducted from the total static pressure of the blower.  
\* Do **NOT** close the pulley below 1 turn open.  
\*\* Factory setting.



**TABLE 14: SUPPLY AIR BLOWER PERFORMANCE (20 TON) - GAS HEAT  
240 MBH - BOTTOM DUCT CONNECTIONS**

BLOWER SPEED, (RPM)	MOTOR PULLEY (TURNS OPEN)*	CFM														
		6000			7000			8000			9000			9400		
		ESP	BHP	KW	ESP	BHP	KW	ESP	BHP	KW	ESP	BHP	KW	ESP	BHP	KW
<b>208 VOLT AND STANDARD DRIVE</b>																
870	6.0**	1.3	3.6	3.0	0.7	4.3	3.7	0.2	5.1	4.3	-	-	-	-	-	-
900	5.0	1.4	3.8	3.2	0.9	4.7	4.0	0.4	5.6	4.7	-	-	-	-	-	-
930	4.0	1.6	4.1	3.4	1.1	5.0	4.2	0.6	5.9	5.0	0.1	6.7	5.7	-	-	-
950	3.0	1.7	4.2	3.6	1.3	5.1	4.3	0.8	6.0	5.1	0.2	6.9	5.8	-	-	-
980	2.0	1.9	4.5	3.8	1.5	5.4	4.5	1.0	6.3	5.3	0.4	7.2	6.1	0.1	8.5	7.1
995	1.5	2.1	4.6	3.9	1.6	5.5	4.7	1.1	6.4	5.4	0.5	7.5	6.3	0.2	8.6	7.3
1015	1.0	2.2	4.8	4.0	1.7	5.7	4.8	1.2	6.6	5.6	0.6	7.8	6.6	-	-	-
<b>208 VOLT AND HIGH STATIC DRIVE</b>																
950	6.0	1.7	4.2	3.6	1.3	5.1	4.3	0.8	6.0	5.1	0.2	6.9	5.8	-	-	-
980	5.0	1.9	4.5	3.8	1.5	5.4	4.5	1.0	6.3	5.3	0.4	7.2	6.1	0.1	8.5	7.1
995	4.5	2.1	4.5	3.9	1.6	5.5	4.7	1.1	6.4	5.4	0.5	7.5	6.3	0.2	8.6	7.3
1025	3.5	2.3	4.9	4.1	1.8	5.8	4.9	1.3	6.7	5.7	0.7	8.0	6.7	-	-	-
1050	2.5	2.5	5.1	4.3	2.0	6.1	5.1	1.4	7.1	6.0	0.9	8.4	7.0	-	-	-
1065	2.0	2.6	5.3	4.4	2.1	6.3	5.3	1.5	7.3	6.2	1.0	8.6	7.2	-	-	-
1100	1.0	2.9	5.6	4.7	2.3	6.8	5.7	1.8	7.9	6.6	-	-	-	-	-	-
<b>230/460/575 VOLT AND STANDARD DRIVE</b>																
870	6.0**	1.3	3.6	3.0	0.7	4.3	3.7	0.2	5.1	4.3	-	-	-	-	-	-
900	5.0	1.4	3.8	3.2	0.9	4.7	4.0	0.4	5.6	4.7	-	-	-	-	-	-
930	4.0	1.6	4.1	3.4	1.1	5.0	4.2	0.6	5.9	5.0	0.1	6.7	5.7	-	-	-
950	3.5	1.7	4.2	3.6	1.3	5.1	4.3	0.8	6.0	5.1	0.2	6.9	5.8	-	-	-
965	2.5	1.9	4.5	3.8	1.5	5.4	4.5	1.0	6.3	5.3	0.4	7.2	6.1	0.1	8.5	7.1
995	2.0	2.1	4.6	3.9	1.6	5.5	4.7	1.1	6.4	5.4	0.5	7.5	6.3	0.2	8.6	7.3
1015	1.5	2.2	4.8	4.0	1.7	5.7	4.8	1.2	6.6	5.6	0.6	7.8	6.6	-	-	-
1025	1.0	2.3	4.9	4.1	1.8	5.8	4.9	1.3	6.7	5.7	0.7	8.0	6.7	-	-	-
<b>230/460/575 VOLT AND HIGH STATIC DRIVE</b>																
950	6.0	1.7	4.2	3.6	1.3	5.1	4.3	0.8	6.0	5.1	0.2	6.9	5.8	-	-	-
980	5.0	1.9	4.5	3.8	1.5	5.4	4.5	1.0	6.3	5.3	0.4	7.2	6.1	0.1	8.5	7.1
995	4.5	2.1	4.6	3.9	1.6	5.5	4.7	1.1	6.4	5.4	0.5	7.5	6.3	0.2	8.6	7.3
1015	4.0	2.2	4.8	4.0	1.7	5.7	4.8	1.2	6.6	5.6	0.6	7.8	6.6	-	-	-
1025	3.5	2.3	4.9	4.1	1.8	5.8	4.9	1.3	6.7	5.7	0.7	8.0	6.7	-	-	-
1050	3.0	2.5	5.1	4.3	2.0	6.1	5.1	1.4	7.1	6.0	0.9	8.4	7.0	-	-	-
1065	2.5	2.6	5.3	4.4	2.1	6.3	5.3	1.5	7.3	6.2	1.0	8.6	7.2	-	-	-
1100	1.5	2.9	5.6	4.7	2.3	6.8	4.7	1.8	7.9	6.6	-	-	-	-	-	-
1120	1.0	3.1	5.8	4.9	2.5	7.0	5.9	1.9	8.3	6.9	-	-	-	-	-	-

NOTES: 1. Blower performance includes a gas-fired heat exchanger, fixed outdoor air, two-inch T/A filters and a dry evaporator coil.  
 2. Refer to the additional Static Resistances table.  
 ESP = External Static Pressure available for the supply and return air duct system. All internal unit resistances have been deducted from the total static pressure of the blower.  
 \* Do **NOT** close the pulley below 1 turn open.  
 \*\* Factory setting.

**TABLE 15: SUPPLY AIR BLOWER PERFORMANCE (25 TON) - GAS HEAT  
300 MBH - BOTTOM DUCT CONNECTIONS**

BLOWER SPEED, (RPM)	MOTOR PULLEY (TURNS OPEN)*	CFM														
		7500			8750			10000			11250			12500		
		ESP	BHP	KW	ESP	BHP	KW	ESP	BHP	KW	ESP	BHP	KW	ESP	BHP	KW
<b>208 VOLT AND STANDARD DRIVE</b>																
975	6.0	1.2	5.9	4.9	5.0	7.3	6.0	-	-	-	-	-	-	-	-	-
1005	5.0	1.4	6.2	5.1	0.7	7.7	6.3	-	-	-	-	-	-	-	-	-
1040	4.0	1.6	6.6	5.4	0.9	8.1	6.7	0.2	9.7	8.0	-	-	-	-	-	-
1070	3.0	1.8	6.9	5.7	1.1	8.5	7.0	0.4	10.2	8.3	-	-	-	-	-	-
1100	2.0	2.0	7.3	6.0	1.3	8.9	7.3	0.6	10.6	8.7	-	-	-	-	-	-
1135	1.0	2.2	7.7	6.3	1.6	9.3	7.6	0.8	11.1	9.1	-	-	-	-	-	-
1165	0.0	2.4	8.0	6.6	1.8	9.7	8.0	1.0	11.6	9.5	0.2	13.5	11.0	-	-	-
<b>208 VOLT AND HIGH STATIC DRIVE</b>																
1140	6.0	2.2	7.7	6.3	1.6	9.4	7.7	0.9	11.2	9.2	-	-	-	-	-	-
1180	5.0	2.5	8.2	6.7	1.9	9.9	8.1	1.2	11.8	9.7	0.3	13.7	11.2	-	-	-
1215	4.0	2.7	8.6	7.0	2.1	10.4	8.5	1.4	12.3	10.1	0.6	14.3	11.7	-	-	-
1255	3.0	3.0	9.1	7.4	2.4	11.0	9.0	1.7	12.9	10.6	0.9	15.0	12.3	-	-	-
1290	2.0	3.2	9.5	7.8	2.7	11.5	9.4	2.0	13.5	11.1	1.2	15.6	12.8	-	-	-
1330	1.0	3.5	10.0	8.2	3.0	12.0	9.9	2.3	14.1	11.6	1.5	16.4	13.4	-	-	-
1365	0.0	3.7	10.5	8.6	3.2	12.6	10.3	2.6	14.7	12.1	1.8	17.0	13.9	-	-	-
<b>230/460/575 VOLT AND STANDARD DRIVE</b>																
975	6.0*	1.4	5.9	4.9	1.0	7.3	6.0	0.5	8.8	7.2	-	-	-	-	-	-
1005	5.0	1.6	6.2	5.1	1.2	7.7	6.3	0.7	9.2	7.6	0.1	10.9	8.9	-	-	-
1040	4.0	1.8	6.6	5.4	1.4	8.1	6.7	0.9	9.7	8.0	0.3	11.4	9.4	-	-	-
1070	3.0	2.0	6.9	5.7	1.6	8.5	7.0	1.1	10.2	8.3	0.6	11.9	9.8	-	-	-
1100	2.0	2.1	7.3	6.0	1.8	8.9	7.3	1.3	10.6	8.7	0.8	12.4	10.2	0.2	14.3	11.7
1135	1.0	2.4	7.7	6.3	2.0	9.3	7.6	1.6	11.1	9.1	1.0	13.0	10.6	0.4	14.9	12.2
1165	0.0	2.6	8.0	6.6	2.2	9.7	8.0	1.8	11.6	9.5	1.3	13.5	11.0	0.7	15.5	12.7
<b>230/460/575 VOLT AND HIGH STATIC DRIVE</b>																
1140	6.0	2.4	7.7	6.3	2.1	9.4	7.7	1.6	11.2	9.2	1.1	13.1	10.7	0.5	15.0	12.3
1180	5.0	2.7	8.2	6.7	2.3	9.9	8.1	1.9	11.8	9.7	1.4	13.7	11.2	0.8	15.8	12.9
1215	4.0	2.9	8.6	7.0	2.6	10.4	8.5	2.2	12.3	10.1	1.7	14.3	11.7	1.1	16.4	13.5
1255	3.0	3.2	9.1	7.4	2.9	11.0	9.0	2.5	12.9	10.6	2.0	15.0	12.3	1.4	17.2	14.1
1290	2.0	3.4	9.5	7.8	3.1	11.5	9.4	2.7	13.5	11.1	2.2	15.6	12.8	-	-	-
1330	1.0	3.7	10.0	8.2	3.4	12.0	9.9	3.0	14.1	11.6	2.6	16.4	13.4	-	-	-
1365	0.0	3.9	10.5	8.6	3.7	12.6	10.3	3.3	14.7	12.1	2.9	17.0	13.9	-	-	-

- NOTES: 1. Blower performance includes a gas-fired heat exchanger, fixed outdoor air, two-inch T/A filters and a dry evaporator coil.  
2. Refer to the additional Static Resistances table.  
ESP = External Static Pressure available for the supply and return air duct system. All internal unit resistances have been deducted from the total static pressure of the blower.  
\* Do **NOT** close the pulley below 1 turn open.  
\*\* Factory setting.

15 HP Motor is required.

**TABLE 16: BLOWER MOTOR AND DRIVE DATA**

MODEL SIZE	DRIVE	BLOWER RANGE (RPM)	MOTOR <sup>1</sup>			ADJUSTABLE MOTOR PULLEY				FIXED BLOWER PULLEY				BELT (NOTCHED)		
			HP	FRAME	EFF. (%)	DESIG-NATION	OUTSIDE DIA. (IN.)	PITCH DIA. (IN.)	BORE (IN.)	DESIG-NATION	OUTSIDE DIA. (IN.)	PITCH DIA. (IN.)	BORE (IN.)	DESIG-NATION	PITCH LENGTH (IN.)	QTY.
15 TON	Standard	850/1065	5	184 T	83	1VP56	5.35	4.3-5.3 <sup>2</sup>	1-1/8	BK90	8.75	8.4	1	BX70	82.8	1
	High Static	965/1190								BK80	7.75	7.4	1	BX68	69.8	1
17.5 & 20 TON	Standard	870/1025	7.5	213 T	89	1VP68	6.75	5.5-6.5 <sup>2</sup>	1-3/8	BK120	11.75	11.4	1-3/16	BX83	84.8	1
	High Static	950/1120								BK110	10.75	10.4	1-3/16	BX81	82.8	1
25 TON	Standard	950/1120	10	215 T	89.5	1VP68	6.75	5.5-6.5 <sup>2</sup>	1-3/8	1B5V110	11.3	11.1	1-7/16	BX81	82.8	1
	High Static	1140/1365	15	254 T	91	1VP75X	7.5	6.2-7.4	1-5/8	1B5V94	9.7	9.5	1-7/16	5VX840	84.0	1

1. All motors have a nominal speed of 1800 RPM, a 1.15 service factor and a solid base. They can operate to the limit of their service factor because they are located in the moving air, upstream of any heating device.
2. Do NOT close this pulley below 1 turn open.

**TABLE 17: STATIC RESISTANCES<sup>1</sup>**

DESCRIPTION		RESISTANCE, IWG											
		CFM											
		15 TON			17.5 TON			20 TON			25 TON		
		4500	6000	7200	6000	8000	9000	6000	7000	9400	7500	10000	12500
WET COIL		0.1	0.1	0.1	0.1	0.1	0.1	0.1	0.1	0.1	0.1	0.1	0.1
ELECTRIC HEAT OPTIONS (DH models only)	18kW	0.3	0.4	0.4	0.4	0.4	0.5	0.4	0.4	0.5	0.4	0.6	0.6
	36kW	0.3	0.4	0.5	0.4	0.5	0.5	0.4	0.5	0.5	0.5	0.5	0.6
	54kW	0.4	0.5	0.5	0.5	0.5	0.6	0.5	0.5	0.6	0.5	0.6	0.7
	72kW	0.4	0.5	0.5	0.5	0.5	0.6	0.5	0.5	0.6	0.5	0.6	0.7
ECONOMIZER OPTION		0.1	0.1	0.1	0.1	0.1	0.2	0.1	0.1	0.2	0.1	0.2	0.3
HORIZONTAL DUCT CONNECTIONS <sup>2</sup>		0.1	0.2	0.3	0.2	0.3	0.5	0.2	0.3	0.5	0.3	0.5	0.6

1. Deduct these resistance values from the available unit ESP values listed in the respective blower performance table except for Horizontal Duct Connections.
2. Since the resistance to air flow will be less for horizontal duct connections than for bottom duct connections, add these pressures to the ESP values on the respective unit's blower performance table.

**TABLE 18: POWER EXHAUST PERFORMANCE**

MOTOR SPEED <sup>1</sup>	STATIC RESISTANCE OF RETRUN DUCTWORK, IWG									
	0.2		0.3		0.4		0.5		0.6	
	CFM	kW	CFM	kW	CFM	kW	CFM	kW	CFM	kW
HIGH <sup>2</sup>	5250	0.83	4500	0.85	4200	0.88	3750	0.93	3000	0.99
MEDIUM	4900	0.77	3900	0.79	3500	0.82	2900	0.85	-	-
LOW	4400	0.72	3700	0.74	3000	0.78	-	-	-	-

1. Power exhaust motor is a 3/4 HP, PSC type with sleeve bearings, a 48 frame and inherent protection.
2. The factory setting.

**TABLE 19: DH 180, 210 & 240 ELECTRICAL DATA WITHOUT POWERED CONVENIENCE OUTLET**

MODEL (TON-NAGE)	VOLTAGE	COMPRESSORS		OD FAN MOTORS FLA EACH	ID BLOWER MOTOR FLA	CONV OUTLET AMPS	HEATER OPTION				MIN. CIRCUIT AMPACITY (AMPS)	MAX. FUSE/ BRKR <sup>1</sup> SIZE (AMPS)
		RLA EACH	LRA EACH				MODEL	KW	STAGES	AMPS		
DH180 (15)	208-3-60	21.8	184	4.5	12.8	0.0	None	--	--	--	70.9	90
							E18	13.5	1	37.5	70.9	90
							E36	27	2	74.9	109.7	110
							E54	40.6	2	112.7	156.9	175
							E72	54.1	2	150.2	166.2	200
	230-3-60	21.8	184	4.3	12.8	0.0	None	--	--	--	70.5	90
							E18	18.0	1	43.3	70.5	90
							E36	36.0	2	86.6	124.3	125
							E54	54.0	2	129.9	145.9	175
							E72	72.0	2	173.2	189.2	225
	460-3-60	11.0	90	2.2	6.4	0.0	None	--	--	--	35.6	45
							E18	18.0	1	21.7	35.6	45
							E36	36.0	2	43.3	62.1	70
							E54	54.0	2	65.0	73.0	80
							E72	72.0	2	86.6	94.6	110
	575-3-60	9.6	73	1.7	5.2	0.0	None	--	--	--	30.2	35
E18							18.0	1	17.3	30.2	35	
E36							36.0	2	34.6	49.8	50	
E54							54.0	2	52.0	58.5	70	
E72							72.0	2	69.3	75.8	90	
DH210 (17 1/2)	208-3-60	25.6	190	4.5	20.0	0.0	None	--	--	--	86.6	110
							E18	13.5	1	37.5	86.6	110
							E36	27	2	74.9	118.7	125
							E54	40.6	2	112.7	165.9	175
							E72	54.1	2	150.2	175.2	200
	230-3-60	25.6	190	4.3	20.0	0.0	None	--	--	--	86.2	110
							E18	18.0	1	43.3	86.2	110
							E36	36.0	2	86.6	133.3	150
							E54	54.0	2	129.9	154.9	175
							E72	72.0	2	173.2	198.2	225
	460-3-60	12.8	95	2.2	10.0	0.0	None	--	--	--	43.2	50
							E18	18.0	1	21.7	43.2	50
							E36	36.0	2	43.3	66.6	70
							E54	54.0	2	65.0	77.5	90
							E72	72.0	2	86.6	99.1	110
	575-3-60	10.2	75	1.7	7.5	0.0	None	--	--	--	33.9	40
E18							18.0	1	17.3	33.9	40	
E36							36.0	2	34.6	52.7	60	
E54							54.0	2	52.0	61.3	70	
E72							72.0	2	69.3	78.7	90	
DH240 (20)	208-3-60	32.1	237	4.5	20.0	0.0	None	--	--	--	101.2	125
							E18	13.5	1	37.5	101.2	125
							E36	27	2	74.9	118.7	125
							E54	40.6	2	112.7	165.9	175
							E72	54.1	2	150.2	175.2	200
	230-3-60	32.1	237	4.3	20.0	0.0	None	--	--	--	100.8	125
							E18	18.0	1	43.3	100.8	125
							E36	36.0	2	86.6	133.3	150
							E54	54.0	2	129.9	154.9	175
							E72	72.0	2	173.2	198.2	225
	460-3-60	14.3	130	2.2	10.0	0.0	None	--	--	--	46.6	60
							E18	18.0	1	21.7	46.6	60
							E36	36.0	2	43.3	66.6	70
							E54	54.0	2	65.0	77.5	90
							E72	72.0	2	86.6	99.1	110
	575-3-60	12.9	85	1.7	7.5	0.0	None	--	--	--	39.9	50
E18							18.0	1	17.3	39.9	50	
E36							36.0	2	34.6	52.7	60	
E54							54.0	2	52.0	61.3	70	
E72							72.0	2	69.3	78.7	90	

NOTE 1: HACR Type per NEC.

**TABLE 20: DH 300 ELECTRICAL DATA STANDARD MOTOR WITHOUT POWERED CONVENIENCE OUTLET**

MODEL (TON-NAGE)	VOLTAGE	COMPRESSORS		OD FAN MOTORS FLA EACH	ID BLOWER MOTOR FLA	CONV OUTLET AMPS	HEATER OPTION				MIN. CIRCUIT AMPACITY (AMPS)	MAX. FUSE/ BRKR <sup>1</sup> SIZE (AMPS)
		RLA EACH	LRA EACH				MODEL	KW	STAGES	AMPS		
300 (25)	208	37.1	239	4.5	28.0	0.0	None	-	-	-	120.5	150
							E18	13.5	1	37.5	120.5	150
							E36	27.0	2	74.9	128.7	150
							E54	40.6	2	112.7	175.9	200
							E72	54.1	2	150.2	185.2	200
	230	37.1	239	4.3	26.0	0.0	None	-	-	-	118.1	150
							E18	18.0	1	43.3	118.1	150
							E36	36.0	2	86.6	140.8	150
							E54	54.0	2	129.9	162.4	175
							E72	72.0	2	173.2	205.7	225
	460	17.2	125	2.2	13.0	0.0	None	-	-	-	56.1	70
							E18	18.0	1	21.7	56.1	70
							E36	36.0	2	43.3	70.4	80
							E54	54.0	2	65.0	81.2	90
							E72	72.0	2	86.6	102.9	110
	575	12.4	80	1.7	10.0	0.0	None	-	-	-	41.3	50
							E18	18.0	1	17.3	41.3	50
							E36	36.0	2	34.6	55.8	60
							E54	54.0	2	52.0	64.5	70
							E72	72.0	2	69.3	81.8	90

NOTE 1: HACR Type per NEC.

**TABLE 21: DH 300 ELECTRICAL DATA HIGH STATIC MOTOR WITHOUT POWERED CONVENIENCE OUTLET**

MODEL (TON-NAGE)	VOLTAGE	COMPRESSORS		OD FAN MOTORS FLA EACH	ID BLOWER MOTOR FLA	CONV OUTLET AMPS	HEATER OPTION				MIN. CIRCUIT AMPACITY (AMPS)	MAX. FUSE/ BRKR <sup>1</sup> SIZE (AMPS)
		RLA EACH	LRA EACH				MODEL	KW	STAGES	AMPS		
300 (25)	208	37.1	239	4.5	38.6	0.0	None	-	-	-	131.5	150
							E18	13.5	1	37.5	131.5	150
							E36	27.0	2	74.9	141.9	150
							E54	40.6	2	112.7	189.1	200
							E72	54.1	2	150.2	198.4	225
	230	37.1	239	4.3	38.6	0.0	None	-	-	-	131.1	150
							E18	18.0	1	43.3	131.1	150
							E36	36.0	2	86.6	156.5	175
							E54	54.0	2	129.9	178.2	200
							E72	72.0	2	173.2	221.5	250
	460	17.2	125	2.2	19.3	0.0	None	-	-	-	62.9	80
							E18	18.0	1	21.7	62.9	80
							E36	36.0	2	43.3	78.3	80
							E54	54.0	2	65.0	89.1	100
							E72	72.0	2	86.6	110.7	125
	575	12.4	80	1.7	15.4	0.0	None	-	-	-	47.5	60
							E18	18.0	1	17.3	47.5	60
							E36	36.0	2	34.6	62.6	70
							E54	54.0	2	52.0	71.2	80
							E72	72.0	2	69.3	88.5	100

NOTE 1: HACR Type per NEC.

**TABLE 22: DH 180, 210 & 240 ELECTRICAL DATA WITH POWERED CONVENIENCE OUTLET**

MODEL (TON-NAGE)	VOLTAGE	COMPRESSORS		OD FAN MOTORS FLA EACH	ID BLOWER MOTOR FLA	CONV OUTLET AMPS	HEATER OPTION				MIN. CIRCUIT AMPACITY (AMPS)	MAX. FUSE/ BRKR <sup>1</sup> SIZE (AMPS)
		RLA EACH	LRA EACH				MODEL	KW	STAGES	AMPS		
DH180 (15)	208-3-60	21.8	184	4.5	12.8	10.0	None	--	--	--	80.9	100
							E18	13.5	1	37.5	80.9	100
							E36	27	2	74.9	122.2	125
							E54	40.6	2	112.7	169.4	175
							E72	54.1	2	150.2	178.7	200
	230-3-60	21.8	184	4.3	12.8	10.0	None	--	--	--	80.5	100
							E18	18.0	1	43.3	82.6	100
							E36	36.0	2	86.6	136.8	150
							E54	54.0	2	129.9	158.4	175
							E72	72.0	2	173.2	201.7	225
	460-3-60	11.0	90	2.2	6.4	5.0	None	--	--	--	40.6	50
							E18	18.0	1	21.7	41.3	50
							E36	36.0	2	43.3	68.4	70
							E54	54.0	2	65.0	79.2	90
							E72	72.0	2	86.6	100.9	110
	575-3-60	9.6	73	1.7	5.2	4.0	None	--	--	--	34.2	40
E18							18.0	1	17.3	34.2	40	
E36							36.0	2	34.6	54.8	60	
E54							54.0	2	52.0	63.5	70	
E72							72.0	2	69.3	80.8	90	
DH210 (17 1/2)	208-3-60	25.6	190	4.5	20.0	10.0	None	--	--	--	96.6	110
							E18	13.5	1	37.5	96.6	110
							E36	27	2	74.9	131.2	150
							E54	40.6	2	112.7	178.4	200
							E72	54.1	2	150.2	187.7	200
	230-3-60	25.6	190	4.3	20.0	10.0	None	--	--	--	96.2	110
							E18	18.0	1	43.3	96.2	110
							E36	36.0	2	86.6	145.8	150
							E54	54.0	2	129.9	167.4	175
							E72	72.0	2	173.2	210.7	225
	460-3-60	12.8	95	2.2	10.0	5.0	None	--	--	--	48.2	60
							E18	18.0	1	21.7	48.2	60
							E36	36.0	2	43.3	72.9	80
							E54	54.0	2	65.0	83.7	90
							E72	72.0	2	86.6	105.4	110
	575-3-60	10.2	75	1.7	7.5	4.0	None	--	--	--	37.9	45
E18							18.0	1	17.3	37.9	45	
E36							36.0	2	34.6	57.7	60	
E54							54.0	2	52.0	66.3	70	
E72							72.0	2	69.3	83.7	90	
DH240 (20)	208-3-60	32.1	237	4.5	20.0	10.0	None	--	--	--	111.2	125
							E18	13.5	1	37.5	111.2	125
							E36	27	2	74.9	131.2	150
							E54	40.6	2	112.7	178.4	200
							E72	54.1	2	150.2	187.7	200
	230-3-60	32.1	237	4.3	20.0	10.0	None	--	--	--	110.8	125
							E18	18.0	1	43.3	110.8	125
							E36	36.0	2	86.6	145.8	150
							E54	54.0	2	129.9	167.4	175
							E72	72.0	2	173.2	210.7	225
	460-3-60	14.3	130	2.2	10.0	5.0	None	--	--	--	51.6	60
							E18	18.0	1	21.7	51.6	60
							E36	36.0	2	43.3	72.9	80
							E54	54.0	2	65.0	83.7	90
							E72	72.0	2	86.6	105.4	110
	575-3-60	12.9	85	1.7	7.5	4.0	None	--	--	--	43.9	50
E18							18.0	1	17.3	43.9	50	
E36							36.0	2	34.6	57.7	60	
E54							54.0	2	52.0	66.3	70	
E72							72.0	2	69.3	83.7	90	

NOTE 1: HACR Type per NEC.

**TABLE 23: DH 300 ELECTRICAL DATA STANDARD MOTOR WITH POWERED CONVENIENCE OUTLET**

MODEL (TON-NAGE)	VOLTAGE	COMPRESSORS		OD FAN MOTORS FLA EACH	ID BLOWER MOTOR FLA	CONV OUTLET AMPS	HEATER OPTION				MIN. CIRCUIT AMPACITY (AMPS)	MAX. FUSE/ BRKR <sup>1</sup> SIZE (AMPS)
		RLA EACH	LRA EACH				MODEL	KW	STAGES	AMPS		
300 (25)	208	37.1	239	4.5	28.0	10.0	None	-	-	-	130.5	150
							E18	13.5	1	37.5	130.5	150
							E36	27.0	2	74.9	141.2	150
							E54	40.6	2	112.7	188.4	200
							E72	54.1	2	150.2	197.7	200
	230	37.1	239	4.3	26.0	10.0	None	-	-	-	128.1	150
							E18	18.0	1	43.3	128.1	150
							E36	36.0	2	86.6	153.3	175
							E54	54.0	2	129.9	174.9	175
							E72	72.0	2	173.2	218.2	225
	460	17.2	125	2.2	13.0	5.0	None	-	-	-	61.1	70
							E18	18.0	1	21.7	61.1	70
							E36	36.0	2	43.3	76.6	80
							E54	54.0	2	65.0	87.5	90
							E72	72.0	2	86.6	109.1	110
	575	12.4	80	1.7	10.0	4.0	None	-	-	-	45.3	50
E18							18.0	1	17.3	45.3	50	
E36							36.0	2	34.6	60.8	70	
E54							54.0	2	52.0	69.5	70	
E72							72.0	2	69.3	86.8	90	

NOTE 1: HACR Type per NEC.

**TABLE 24: DH 300 ELECTRICAL DATA HIGH STATIC MOTOR WITH POWERED CONVENIENCE OUTLET**

MODEL (TON-NAGE)	VOLTAGE	COMPRESSORS		OD FAN MOTORS FLA EACH	ID BLOWER MOTOR FLA	CONV OUTLET AMPS	HEATER OPTION				MIN. CIRCUIT AMPACITY (AMPS)	MAX. FUSE/ BRKR <sup>1</sup> SIZE (AMPS)
		RLA EACH	LRA EACH				MODEL	KW	STAGES	AMPS		
300 (25)	208	37.1	239	4.5	38.6	10.0	None	-	-	-	141.5	175
							E18	13.5	1	37.5	141.5	175
							E36	27.0	2	74.9	154.4	175
							E54	40.6	2	112.7	201.6	225
							E72	54.1	2	150.2	210.9	225
	230	37.1	239	4.3	38.6	10.0	None	-	-	-	141.1	175
							E18	18.0	1	43.3	141.1	175
							E36	36.0	2	86.6	169.0	175
							E54	54.0	2	129.9	190.7	225
							E72	72.0	2	173.2	234.0	250
	460	17.2	125	2.2	19.3	5.0	None	-	-	-	67.9	80
							E18	18.0	1	21.7	67.9	80
							E36	36.0	2	43.3	84.5	90
							E54	54.0	2	65.0	95.3	110
							E72	72.0	2	86.6	117.0	125
	575	12.4	80	1.7	15.4	4.0	None	-	-	-	51.5	60
E18							18.0	1	17.3	51.5	60	
E36							36.0	2	34.6	67.6	70	
E54							54.0	2	52.0	76.2	90	
E72							72.0	2	69.3	93.5	100	

NOTE 1: HACR Type per NEC.

**TABLE 25: DH VOLTAGE LIMITATIONS<sup>1</sup>**

POWER SUPPLY	VOLTAGE	
	MIN.	MAX.
208/230-3-60	187	253
460-3-60	414	506
575-3-60	518	506

1. Utilization Range "A" in accordance with ARI Standard 110.

**TABLE 26: ELECTRIC HEAT CORRECTION FACTORS**

NOMINAL VOLTAGE	VOLTAGE	KW CAP. MULTIPLIER
208	208	1.00
240	230	0.92
480	460	0.92
600	575	0.92

**CONTROL WIRING**

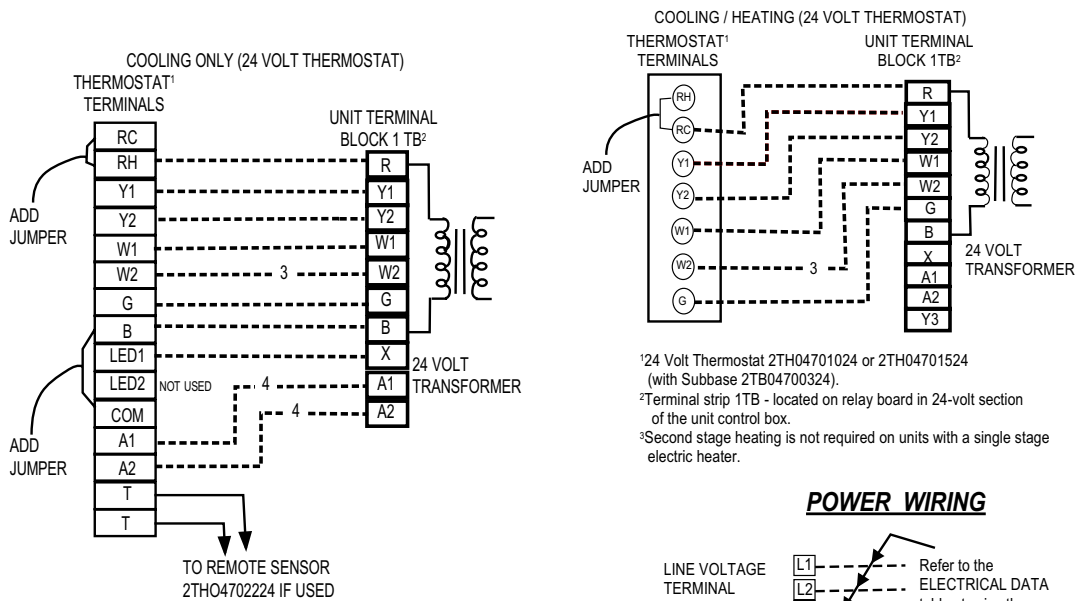

<sup>1</sup>Electronic programmable thermostat 2ET04700224 (includes subbase).  
<sup>2</sup>Terminal block 1TB- located on relay board in 24-volt section of the unit control box.  
<sup>3</sup>Second stage heating is not required on units with a single stage electric heater.  
<sup>4</sup>Terminals A1 and A2 provide a relay output to close the outdoor economizer dampers when the thermostat switches to the set-back position.  
 NOTE: Fans switch must be in "ON" position for minimum ventilation during heater operation.

**FIGURE 3 - TYPICAL DH FIELD WIRING DIAGRAM**

**POWER WIRING**

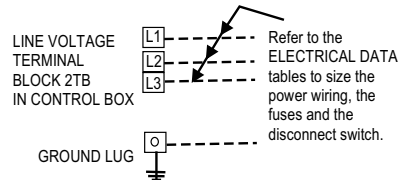

Refer to the ELECTRICAL DATA tables to size the power wiring, the fuses and the disconnect switch.



**TABLE 27: PHYSICAL DATA**

MODELS		DH				
		180	210	240	300	
EVAPORATOR BLOWER	Centrifugal Blower (Dia. x Wd. in.)	15 x 15	18 x 15	18 x 15	18 x 15	
	Fan Motor HP Standard/Hi Static	5	7.5	7.5	10/15	
EVAPORATOR COIL	Rows Deep	4	4	4	4	
	Fins Per Inch	13.5	13.5	13.5	13.5	
	Face Area (Sq. Ft.)	15.5	20.0	20.0	25.0	
CONDENSER FANS (Two Per Unit)	Propeller Dia. (in.) (Each)	30	30	30	30	
	Fan Motor Hp (Each)	1	1	1	1	
	Nom. CFM (Each)	5765	7000	7000	7200	
CONDENSER COILS (Two Per Unit)	Rows Deep (Each)	3	3	3	2	
	Fins Per Inch (Each)	13	15	15	20	
	Face Area (Sq. Ft.) (Total)	36.0	43.3	43.3	43.3	
COMPRESSOR (Qty. Per Unit)	7.5 Ton Scroll	2	2	-	-	
	10 Ton Scroll	-	-	2	-	
	12.5 Ton Scroll	-	-	-	2	
AIR FILTERS	Quantity Per Unit (16" X 20" X 2" or 4")	-	4	4	4	
	Quantity Per Unit (16" X 25" X 2" or 4")	-	4	4	4	
	Quantity Per Unit (18" X 24" X 2" or 4")	5	-	-	-	
	Total Face Area (sq. ft.)	15.0	20.0	20.0	20.0	
CHARGE	Refrigerant 22 (lbs./oz.)	System #1	23/10	24/0	24/2	21/1
		System #2	21/10	24/8	27/2	21/1

**TABLE 28: OPERATING WEIGHTS (LBS.)**

MODEL SIZE		15 TON	17.5 TON	20 TON	25 TON	
BASIC UNIT	DH (Cooling Only)	1900	1950	2100	2345	
	DH (Gas/Electric)	240Mbh	2100	2150	2300	2545
		320Mbh	2140	2190	2340	2585
OPTIONS	Economizer	160				
	Economizer with Power Exhaust	245				
	Motorized Damper	150				
	Electric Heater (DH only)	18kW	25			
		36kW	30			
		54kW	35			
		72kW	40			
Hot Gas Bypass	10					
Supply Fan VFD	See Table 29					
ACCY.	Roof Curb	175	185	185	185	
	Barometric Damper	45				
	Economizer/Motorized Damper Rain Hood	55				
	Economizer/Power Exhaust Rain Hood	90				
	Wood Skid	220				

**TABLE 29: SUPPLY FAN VFD WEIGHTS, IN LBS.**

SUPPLY FAN MOTOR	230V	460V	575V
<b>W/O MANUAL BYPASS</b>			
5.0 hp	25	25	30
7.5 hp	30	30	30
10.0 hp	30	30	35
15.0 hp	30	30	40
<b>W/MANUAL BYPASS</b>			
5.0 hp	30	30	35
7.5 hp	35	35	35
10.0 hp	35	35	40
15.0 hp	40	35	45

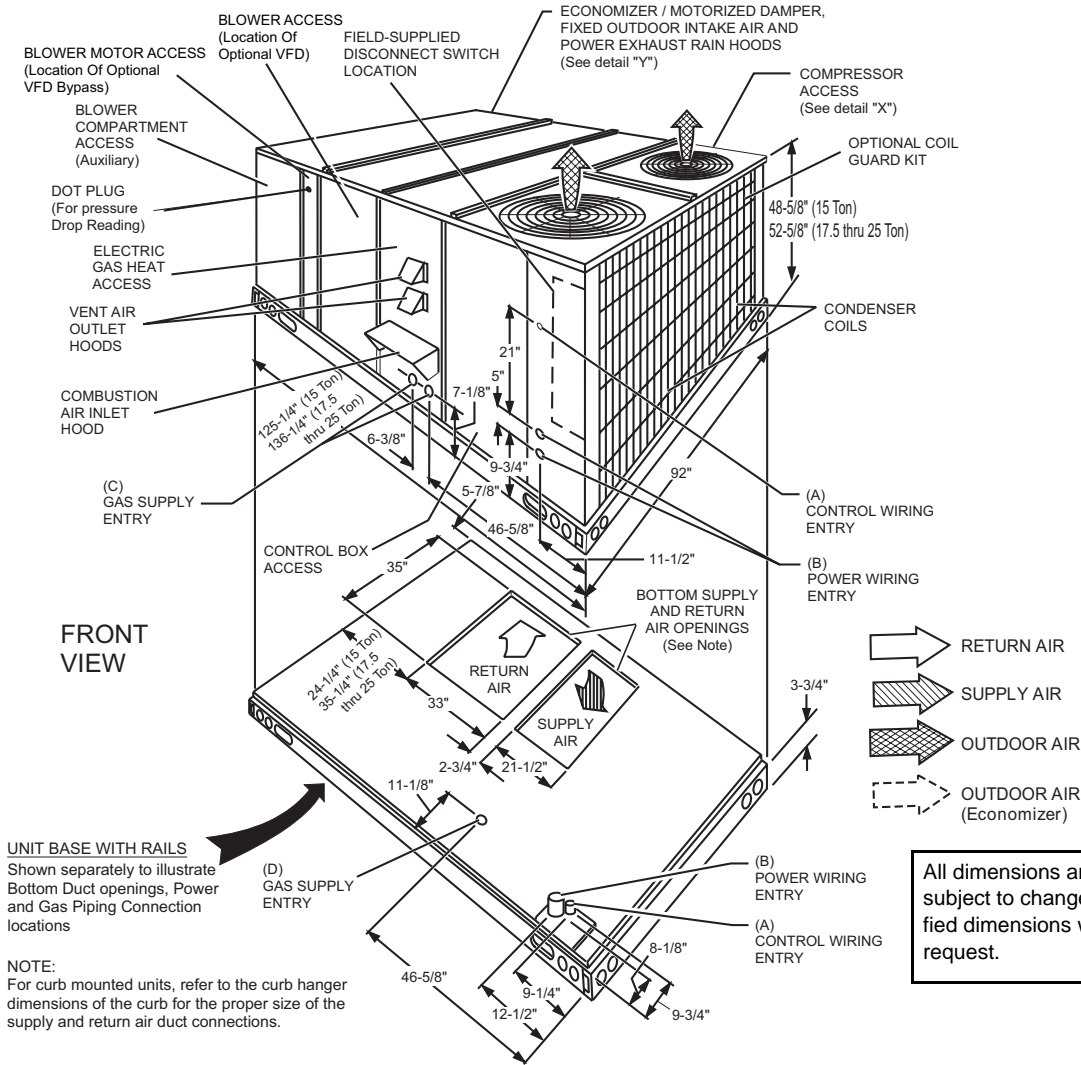

FIGURE 4 - UNIT DIMENSIONS DH180, 210, 240 & 300 (FRONT VIEW)

TABLE 30: UTILITIES ENTRY DATA

HOLE	OPENING SIZE (DIA.)	USED FOR	
A	1-1/8" KO	Control Wiring	Side
	3/4" NPS (Fem.)		Bottom
B	3-5/8" KO	Power Wiring	Side
	3" NPS (Fem.)		Bottom
C	2-3/8" KO	Gas Piping (Front) <sup>1</sup>	
D	1-11/16" Hole	Gas Piping (Bottom) <sup>1, 2</sup>	

1. One-inch gas piping NPT required.

2. Opening in the bottom of the unit can be located by the slice in the insulation.

NOTE: All entry holes should be field sealed to prevent rain water entry into the building.

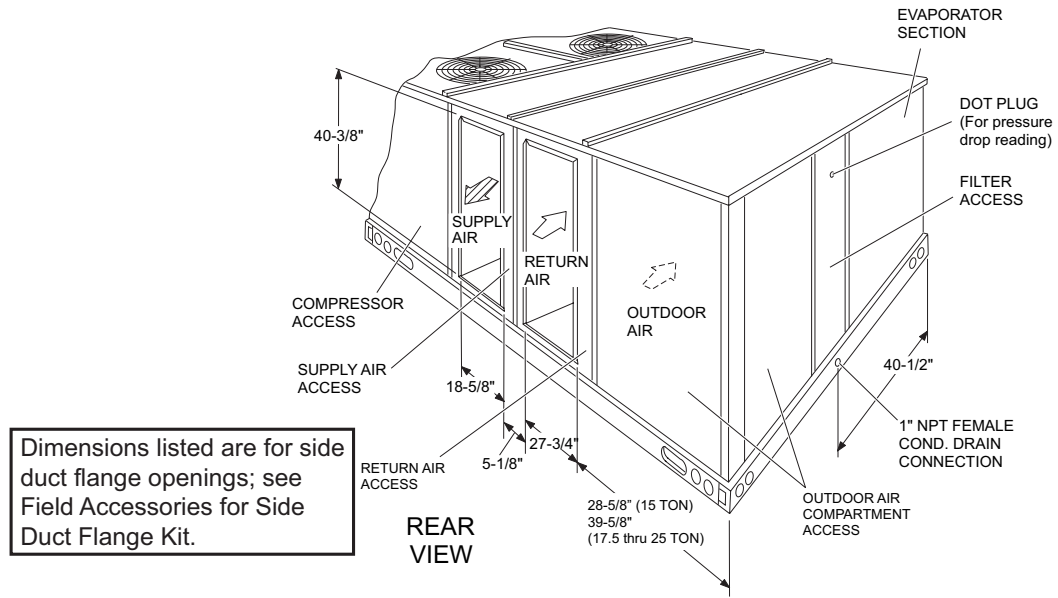

**FIGURE 5 - REAR VIEW DIMENSIONS**

**NOTE:** Units are shipped with the bottom duct openings covered. An accessory flange kit is available for connecting side ducts.

**For bottom duct applications:**

1. Remove the side panels from the supply and return air compartments to gain access to the bottom supply and return air duct covers.
2. Remove and discard the bottom duct covers. Duct openings are closed with sheet metal covers except when the unit includes a power exhaust option. The covering consists of a heavy black paper composition.
3. Replace the side supply and return air compartment panels.

**For side duct applications:**

1. Replace the side panels on the supply and return air compartments with the side duct flange accessory kit panels.
2. Connect ductwork to the flanges on those panels.

**TABLE 31: MINIMUM CLEARANCES**

LOCATION	CLEARANCE
Front	36"
Rear	24" (Less Economizer) 49" (With Economizer)
Left Side (Filter Access)	24" (Less Economizer) 36" (With Economizer) <sup>3</sup>
Right Side (Cond. Coil)	36"
Below Unit <sup>1</sup>	0"
Above Unit <sup>2</sup>	72" With 36" Maximum Horizontal Overhang (For Condenser Air Discharge)

1. Units may be installed on combustible floors made from wood or class A, B, or C roof covering material.
2. Units must be installed outdoors. Overhanging structures or shrubs should not obstruct condenser air discharge outlet.
3. If economizer is factory installed, the unassembled rain hood must be removed from its ride along position in front of evaporator coil, or in the outdoor air compartment, prior to final installation.

**NOTE:** ELEC / ELEC Models: Units and ductwork are approved for zero clearance to combustible material when equipped with electric heaters.

GAS / ELEC Models: A 1" clearance must be provided between any combustible material and the supply air ductwork for a distance of 3 feet from the unit.

The products of combustion must not be allowed to accumulate within a confined space and recirculate.

Locate unit so that the vent air outlet hood is at least:

- Three (3) feet above any force air inlet located within 10 horizontal feet (excluding those integral to the unit).
- Four (4) feet below, four horizontal feet from, or one foot above any door or gravity air inlet into the building.
- Four (4) feet from electric and gas meters, regulators and relief equipment.

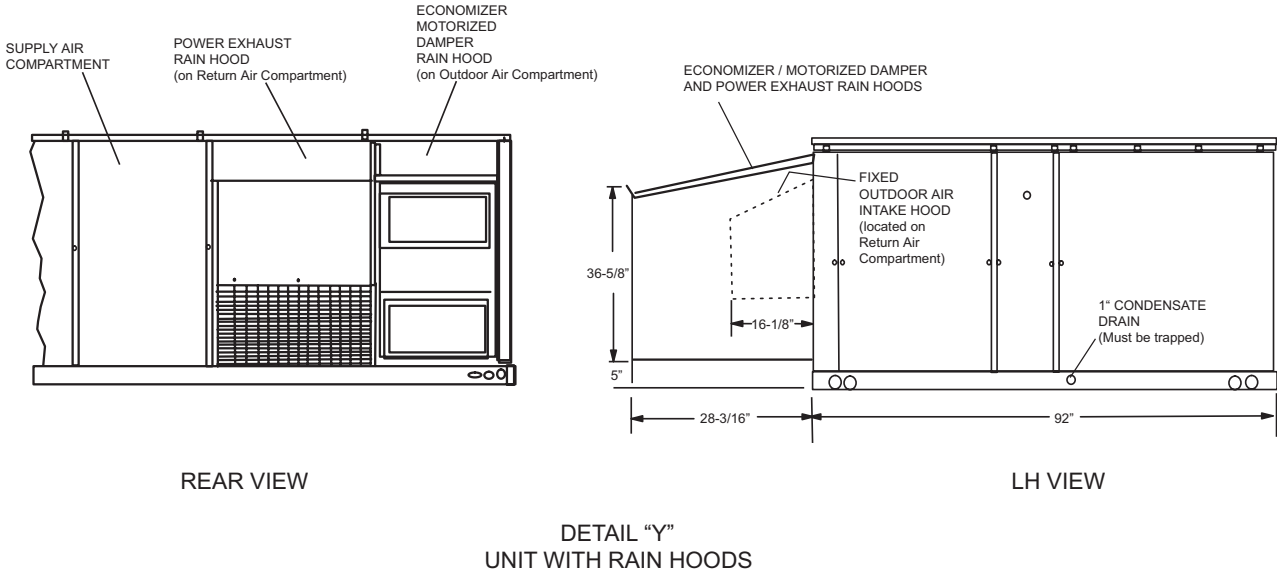

**FIGURE 6 - UNIT DIMENSIONS DH180, 210, 240 & 300 (RAINHOOD)**

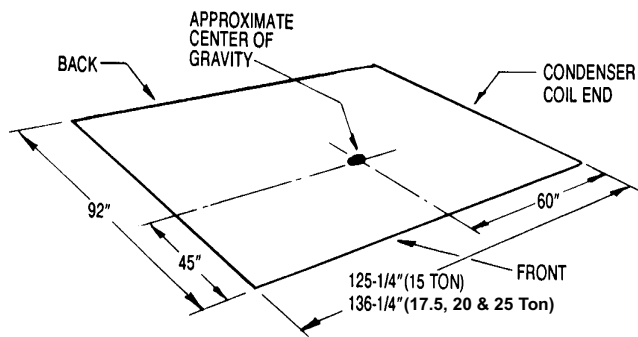

FIGURE 7 - UNIT CENTER OF GRAVITY

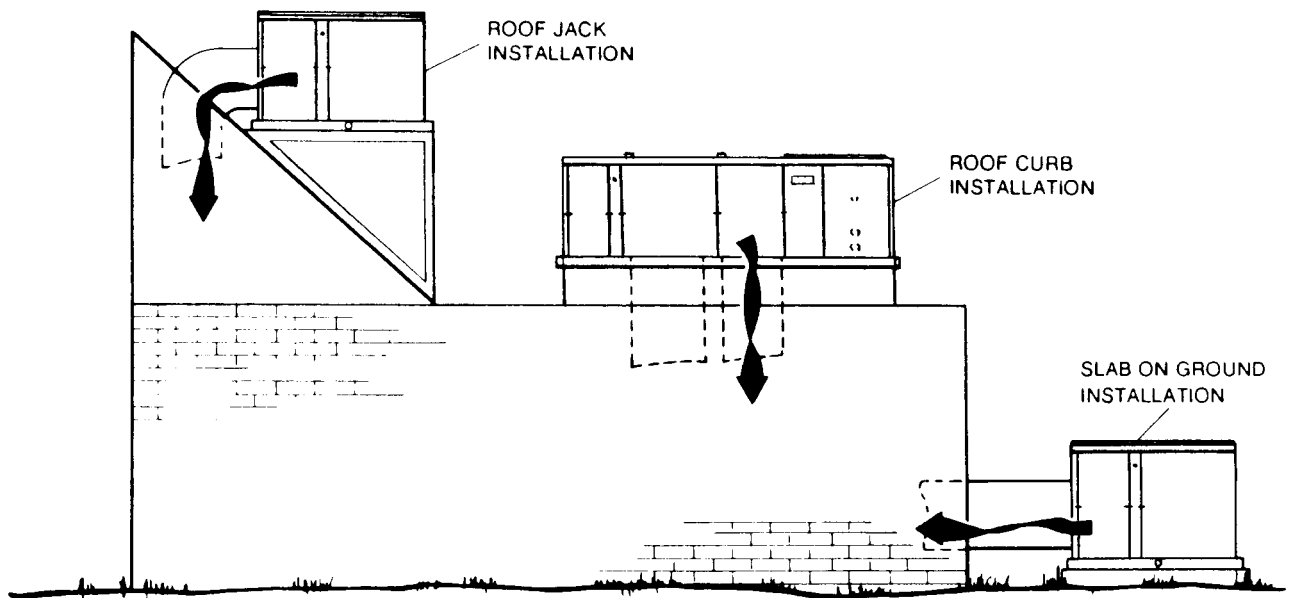

FIGURE 8 - TYPICAL UNIT APPLICATIONS

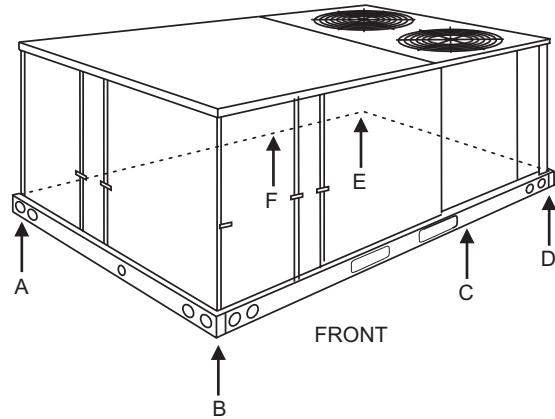
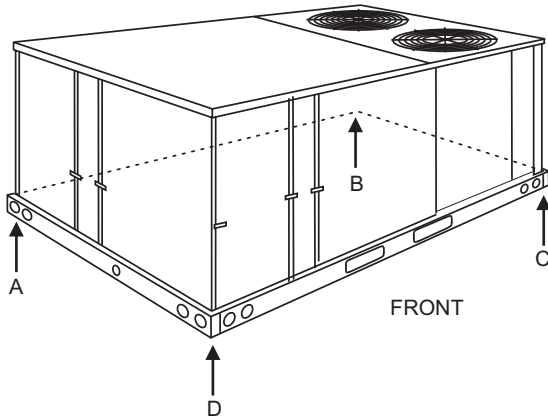

FIGURE 9 - UNIT 4 POINT LOAD

FIGURE 10 - UNIT 6 POINT LOAD

TABLE 32: DH 180, 210, 240 & 300 4 POINT LOAD WEIGHT DISTRIBUTION

UNIT MODEL	OPERATING WEIGHT (lb)	A	B	C	D
DH180C00	1900	445	484	506	465
DH180N24	2100	492	535	559	514
DH180N32	2140	501	545	570	524
DH210C00	1950	457	497	519	477
DH210N24	2150	504	548	572	526
DH210N32	2190	513	558	583	536
DH240C00	2100	492	535	559	514
DH240N24	2300	539	586	612	563
DH240N32	2340	548	596	623	573
DH300C00	2345	461	502	720	662
DH300N24	2545	501	545	781	718
DH300N32	2585	509	553	794	729

TABLE 33: DH 180, 210, 240 & 300 6 POINT LOAD WEIGHT DISTRIBUTION

UNIT MODEL	OPERATING WEIGHT (lb)	A	B	C	D	E	F
DH180C00	1900	293	306	323	342	327	309
DH180N24	2100	324	338	357	378	362	342
DH180N32	2140	330	344	364	385	369	348
DH210C00	1950	300	314	332	351	336	317
DH210N24	2150	331	346	366	387	370	350
DH210N32	2190	337	352	372	394	377	357
DH240C00	2100	324	338	357	378	362	342
DH240N24	2300	354	370	391	414	396	374
DH240N32	2340	360	377	398	421	403	381
DH300C00	2345	303	321	339	487	460	435
DH300N24	2545	329	348	368	528	499	472
DH300N32	2585	334	353	374	537	507	479

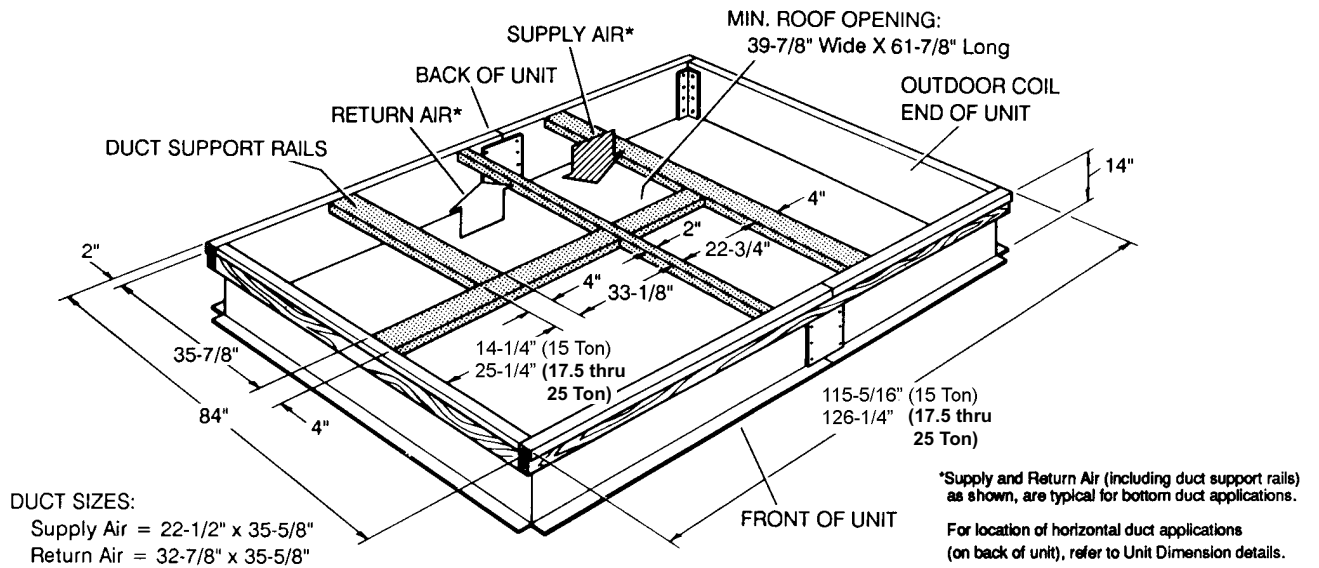

**FIGURE 11 - UNIT ROOF CURB DIMENSIONS**

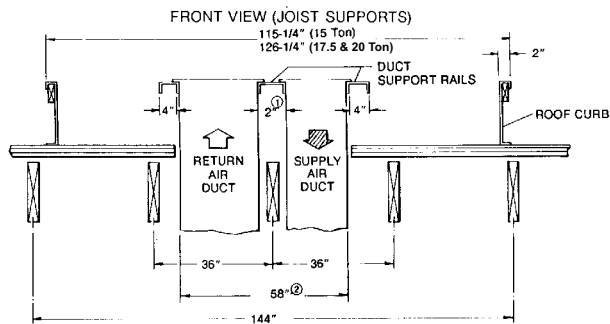

**FIGURE 12 - ROOF CURB DUCT OPENINGS DIMENSIONS**

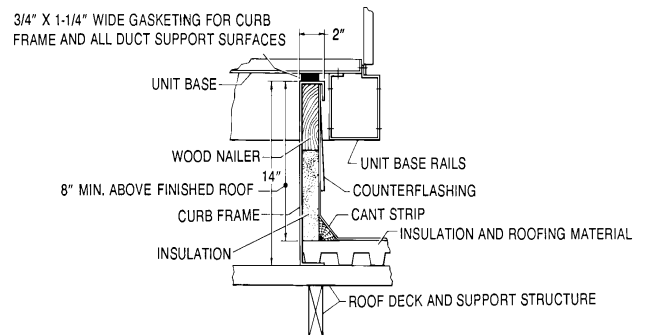

**FIGURE 13 - CUT AWAY OF ROOF CURB**

1. The 2" space between the ducts allows for "jumping" an existing roof joist.
2. The 58-1/2" overall dimension of the ducts allows ductwork penetration between roof joists that are spaced on 72" centers.

**NOTE:** Ducts can be installed into the curb from the roof. All electrical and gas line connections can be made inside the curb.

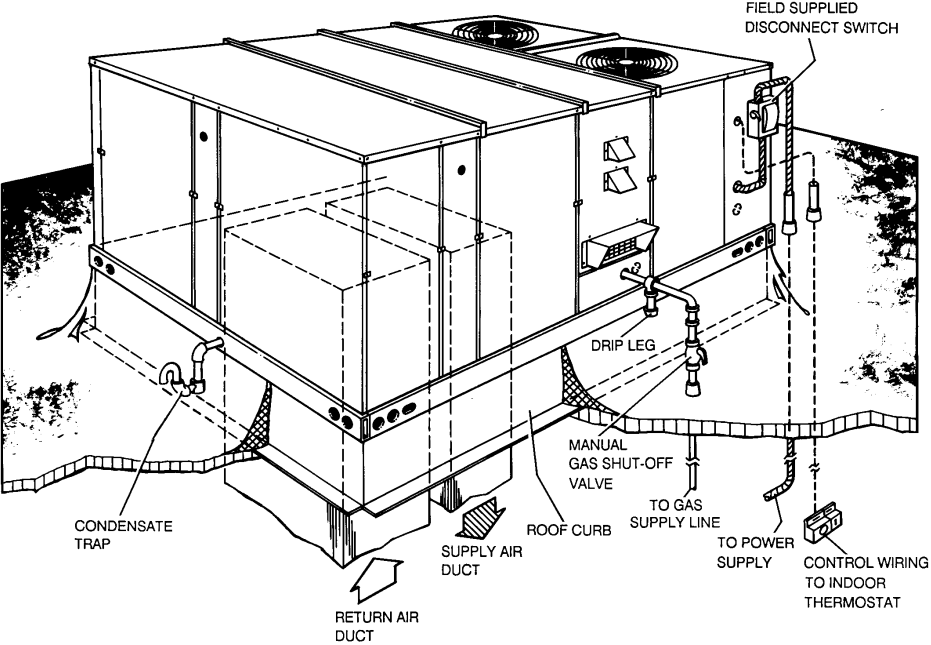
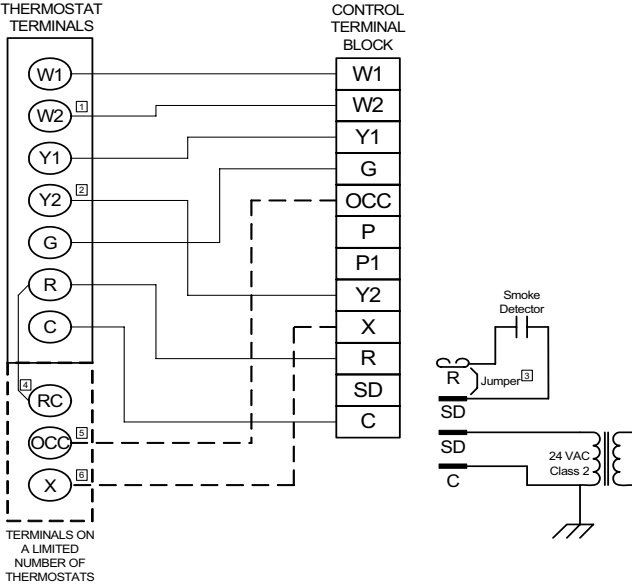

FIGURE 14 - TYPICAL ROOFTOP INSTALLATION



- 1 Second stage heating not required on single stage heating units.
- 2 Second stage cooling not required on single stage cooling units.
- 3 Jumper is required if there is no Smoke Detector circuit.
- 4 Jumper is required for any combination of R, RC, or RH.
- 5 OCC is an output from the thermostat to indicate the Occupied condition.
- 6 X is an input to the thermostat to display Error Status conditions.

FIGURE 15 - TYPICAL SIMPLICITY® CONTROL WIRING DIAGRAM



## GUIDE SPECIFICATIONS

### GENERAL

Units shall be manufactured by York International Unitary Products Group in an ISO 9001 certified facility.

York's Sunline Ultra™ units are convertible single package units. All models have dual independent refrigerant circuits for efficient part load operation and maximum comfort control. Although the units are primarily designed for curb mounting on a roof, they can also be slab-mounted at ground level or set on steel beams above a finished roof. Cooling only, cooling with gas heat and cooling with electric heat models are available with a wide variety of factory-mounted options and field-installed accessories to make them suitable for almost every application. All units are self-contained and assembled on full perimeter base rails with holes in the four corners for overhead rigging. Every unit is completely piped, wired, charged and tested at the factory to simplify the field installation and to provide years of dependable operation. All models (including those with an economizer) are suitable for either bottom or horizontal duct connections. Models with power exhaust are suitable for bottom duct connections only. For bottom duct, remove the sheet metal panels from the supply and return air openings through the base of the unit. For horizontal duct, replace the supply and return air panels on the rear of the unit with a side duct flange accessory. All supply air blowers are equipped with a belt drive that can be adjusted to meet the exact requirements of the job.

Each unit shall have 2 condenser fan motors. A high static drive option is available for applications with a higher CFM and/or static pressure requirement. All compressors include crankcase heat and internal pressure relief. Every refrigerant circuit includes an expansion valve, a liquid line filter-drier, a discharge line high pressure switch and a suction line with a freeze-stat and low pressure/loss of charge switch. The unit control circuit includes a 75 VA transformer, a 24-volt circuit breaker and a relay board with two compressor lockout circuits, a terminal strip for thermostat wiring, plus an additional set of pin connectors to simplify the interface of additional field controls. All models are CSA approved. All models include a 1-year limited warranty on the complete unit. Compressors and electric heater elements carry an additional 4-year warranty. Aluminized steel tubular heat exchangers carry an additional 9-year warranty.

### DESCRIPTION

Units shall be factory-assembled, single packaged, DH\*\*\*N Electric Cooling/Gas Heat, DH\*\*\*C/E Electric Cooling/Optional Electric Heat, designed for outdoor mounted installation. The 15 ton units shall have minimum EER ratings of 10.8, the 17.5 ton units shall have minimum EER ratings of 10.2, the 20 ton units shall have minimum EER ratings of 9.7 and the 25 ton units shall have minimum EER ratings of 9.6.

They shall have built-in field convertible duct connections for down discharge supply/return or horizontal discharge

supply/return, and be available with factory installed options or field installed accessories. The units shall be factory wired, piped, charged with R-22 refrigerant and factory tested prior to shipment. All unit wiring shall be both numbered and color coded. All units shall be manufactured in a facility certified to ISO 9001 standards and the cooling performance shall be rated in accordance with DOE and ARI test procedures. Units shall be CGA listed, classified to ANSIZ21.47 standards, UL 1995/CAN/CSA No. 236-M90 conditions.

### UNIT CABINET

Unit cabinet shall be constructed of G90 galvanized steel, with exterior surfaces coated with a non-chalking, powdered paint finish, certified at 1000 hour salt spray test per ASTM-B117 standards. Indoor blower section shall be insulated with a minimum 1/2" thick insulation, coated on the airside. Aluminum foil faced insulation shall be used in the furnace compartment and be fastened with ridged fasteners to prevent insulation from entering the air stream. Cabinet panels shall be "large" size, easily removable for servicing and maintenance. Full perimeter base rails shall be provided to assure reliable transit of equipment, overhead rigging and proper sealing on roof curb applications. Disposable 2" filters shall be furnished and be accessible through a removable access door, sealed airtight. Units filter track shall be designed to accommodate either 2" or 4" filters. Fan performance measuring ports shall be provided on the outside of the cabinet to allow accurate air measurements of evaporator fan performance without removing panels or creating air by-pass of the coils. Condensate pan shall be internally sloped and conform to ASHRAE 62-89 self-draining standards. Condensate connection shall be a minimum of 1" I.D. female and be a ridged mount connection. Unit shall incorporate a fixed outdoor air damper with an outdoor air intake opening covered with a bird screen and a rain hood painted to match the exterior of the unit.

### INDOOR (EVAPORATOR) FAN ASSEMBLY

Fan shall be a belt drive assembly and include an adjustable-pitch motor pulley. Job site selected (B.H.P.) brake horsepower shall not exceed the motors nameplate horsepower rating, plus the service factor. Units shall be designed not to operate above service factor. Fan wheel shall be double-inlet type with forward-curved blades, dynamically balanced to operate smoothly throughout the entire range of operation. Airflow design shall be constant air volume.

A variable air volume (VAV) option using a variable frequency drive (VFD) is available for applications requiring a constant supply duct static pressure. Units equipped for VAV shall be controlled by a duct pressure transducer with a 0 - 5" WC pressure range. The pressure transducer shall provide a 0 - 5 VDC output signal to a VAV control board which, in turn shall provide a 2 - 10 VDC speed reference signal to the VFD. The VAV control board shall operate using factory-installed Supply Air, Return Air and Outside Air Temperature Sensors. Units equipped with VFD's shall have factory-installed manual bypass as an option.

## OUTDOOR (CONDENSER) FAN ASSEMBLY

The outdoor fans shall be of the direct-driven propeller type, discharge air vertically, have aluminum blades riveted to corrosion resistant steel spider brackets and shall be dynamically balanced for smooth operation. The 2 outdoor fan motors shall be totally enclosed with permanently lubricated bearings, internally protected against overload conditions and staged independently.

## REFRIGERANT COMPONENTS

Compressors:

- a. Shall be Scroll compressors internally protected with internal high-pressure relief and over temperature protection.
- b. Shall have internal spring isolation and sound muffling to minimize vibration and noise, and be externally isolated on a dedicated, independent mounting.

Coils:

- a. Evaporator and condenser coils shall have aluminum plate fins mechanically bonded to seamless internally enhanced copper tubes with all joints brazed. Special Phenolic coating shall be available as a factory option.
- b. Evaporator and Condenser coils shall be of the direct expansion, draw-thru, design.

Refrigerant Circuit and Refrigerant Safety Components shall include:

- a. Balance-port thermostatic expansion valve with independent circuit feed system.
- b. Filter drier/strainer to eliminate any moisture or foreign matter.
- c. Accessible service gage connections on both suction and discharge lines to charge, evacuate, and measure refrigerant pressure during any necessary servicing or troubleshooting, without losing charge.
- d. The refrigeration system shall provide at least 15° F of sub-cooling at design conditions.
- e. All models shall have two independent circuits.
- f. Hot gas bypass option shall be factory-installed on compressor #1 discharge line to provide cooling in low-load applications. HGBP shall be a standard feature on VAV models and an optional feature on CV models.

## UNIT CONTROLS

- a. Unit shall be complete with self-contained low-voltage control circuit protected by a resettable circuit breaker on the 24-volt transformer side.
- b. Unit shall incorporate a lockout circuit which provides reset capability at the space thermostat or base unit, should any of the following standard safety devices trip and shut off compressor.
  1. High-pressure switch.
- c. Loss-of-charge/Low-pressure switch.

2. Freeze-protection thermostat, evaporator coil. If any of the above safety devices trip, a LED (light-emitting diode) indicator shall flash a diagnostic code that indicates which safety switch has tripped.
- d. Unit shall incorporate "AUTO RESET" compressor over temperature, over current protection.
- e. Unit shall operate with conventional thermostat designs and have a low voltage terminal strip for easy hook-up.
- f. Unit control board shall have on-board diagnostics and fault code display.
- g. Standard controls shall include anti-short cycle and low voltage protection, and permit cooling operation down to 0 °F.
- h. Control board shall monitor each refrigerant safety switch independently.
- i. Control board shall retain last 5 fault codes in non volatile memory, which will not be lost in the event of a power loss.

## GAS HEATING SECTION (DH\*\*\*N MODELS)

Shall be designed with induced draft combustion with post purge logic and energy saving direct spark ignition, redundant main gas valve. Ventor wheel shall be constructed of stainless steel for corrosion resistance. The heat exchanger shall be of the tubular type, constructed of T1-40 aluminized steel for corrosion resistance and allowing minimum mixed air entering temperature of 25° F. Burners shall be of the in-shot type, constructed of aluminum coated steel and contain air mixture adjustments. All gas piping shall enter the unit cabinet at a single location through either the side or curb, without any field modifications. An integrated control board shall provide timed control of evaporator fan functioning and burner ignition. Heating section shall be provided with the following minimum protection:

- a. Primary and auxiliary high-temperature limit switches.
- b. Induced draft motor speed sensor.
- c. Flame roll out switch (automatic reset).
- d. Flame proving controls. Unit shall have two independent stages of capacity.

## ELECTRIC HEATING (DH\*\*\*C/E MODELS)

Nickel chromium electric heating elements shall be provided as required by the application with 1 or 2 stage control, as required, from 13.5 KW to 72 KW capacities. The heating section shall have a primary limit control(s) and automatic reset to prevent the heating element system from operating at an excessive temperature. Units with Electric Heating shall be wired for a single point power supply with branch circuit fusing (where required).

## UNIT OPERATING CHARACTERISTICS

Unit shall be capable of starting and running at 125° F outdoor temperature, exceeding maximum load criteria of ARI Standard 340/360. The compressor, with standard

controls, shall be capable of operation down to 0° F outdoor temperature. Unit shall be provided with fan time delay to prevent cold air delivery before heat exchanger warms up (Gas heat only).

### ELECTRICAL REQUIREMENTS

All unit power wiring shall enter unit cabinet at a single factory provided location and be capable of side or bottom entry, to minimize roof penetrations and avoid unit field modifications. Separate side and bottom openings shall be provided for the control wiring.

### STANDARD LIMITED WARRANTIES

- Compressor 5 Years
- Heat Exchanger 10 Years
- Electric Heat Element 5 Years
- Other Parts 1 Year

**OPTIONAL OUTDOOR AIR** (Shall be made available by either/or):

- **ELECTRONIC ENTHALPY AUTOMATIC ECONOMIZER** - Outdoor and return air dampers that are interlocked and positioned by a fully-modulating, spring-return damper actuator. The maximum leakage rate for the outdoor air intake dampers shall not exceed 2% when dampers are fully closed and operating against a pressure differential of 0.5 IWG. A unit-mounted potentiometer shall be provided to adjust the outdoor and return air damper assembly to take in CFM of outdoor air to meet the minimum ventilation requirement of the conditioned space during normal operation. During economizer operation, a mixed-air temperature control shall modulate the outdoor and return air damper assembly to prevent the supply air temperature from dropping below 55°F. Changeover from compressor to economizer operation shall be provided by an integral electronic enthalpy control that feeds input into the basic module. The outdoor intake opening shall be covered with a rain hood that matches the exterior of the unit. Water eliminator/filters shall be provided. Simultaneous economizer/compressor operation is also possible. Dampers shall fully close on power loss.
- **BAS-READY ECONOMIZER** - Outdoor and return air dampers that are interlocked and positioned by a fully-modulating, spring return damper actuator. The maximum leakage rate for the outdoor air intake dampers shall not exceed 2% when dampers are fully closed and operating against a pressure differential of 0.5 IWG.

For units with optional VAV or Simplicity® Intelli-Comfort™ control, free-cooling shall be available while the outdoor dry bulb temperature (OAT) remains below a programmable set-point of the controller. Field-installed humidity sensors for either outdoor air or outdoor & return air streams are available to provide free-cooling based on single-enthalpy or dual-enthalpy configurations, respectively. If free-cooling is available, a call for

cooling shall modulate the economizer in order to maintain a supply air temperature (SAT) programmable set-point. With the use of a field-installed indoor air quality sensor, the controller shall provide Demand Ventilation by modulating the economizer dampers to allow more outside airflow upon detection of elevated indoor CO<sub>2</sub> concentrations above a programmable set-point. With an additional field-installed outdoor air quality sensor, Differential Demand Ventilation shall be provided.

The outdoor intake opening shall be covered with a rain hood that matches the exterior of the unit. Water eliminator/filters shall be provided.

Simultaneous economizer/compressor operation is also possible. Dampers shall fully close on power loss.

- **MOTORIZED OUTDOOR AIR DAMPERS** - Outdoor and return air dampers that are interlocked and positioned by a 2-position, spring-return damper actuator. The maximum leakage rate for the outdoor air intake dampers shall not exceed 2% when dampers are fully closed and operating against a pressure differential of 0.5 IWG. A unit-mounted potentiometer shall be provided to adjust the outdoor and return air damper assembly to take in the design CFM of outdoor air to meet the ventilation requirements of the conditioned space during normal operation. Whenever the indoor fan motor is energized, the dampers open up to one of two pre-selected positions - regardless of the outdoor air enthalpy. Dampers return to the fully closed position when the indoor fan motor is de-energized. Dampers shall fully close on power loss.

### OTHER PRE-ENGINEERED ACCESSORIES AVAILABLE

- **ROOF CURB** - 14" high, full perimeter curb with wood nailer (shipped knocked-down).
- **100% BAROMETRIC RELIEF DAMPER** - Contains a rain hood, air inlet screen, exhaust damper and mounting hardware. Used to relieve internal air pressure through the unit.
- **PROPANE CONVERSION KIT** - Contains new orifices and gas valve parts to convert from natural to L.P. gas. One per unit required.
- **HIGH ALTITUDE - NATURAL GAS** - Contains orifices required for applications between 2000 and 6000 feet altitude.
- **HIGH ALTITUDE - PROPANE GAS** - Contains orifices required for applications between 2000 and 6000 feet altitude. Must be used with propane conversion kit.
- **BURGLAR BARS** - Designed to work with above roof curbs, depending on unit model. Fits duct openings of curb supply and return air openings.
- **SIDE DUCT FLANGE** - Supply and return air duct flanges for side duct applications. Do not use on units with power exhaust.

- **HIGH STATIC DRIVE** - May include a belt, blower pulley, motor pulley or a motor change to enhance blower performance.
- **WOOD SKID** - Allows unit to be handled with 90" forks.
- **ECONOMIZER/MOTORIZED DAMPER RAIN HOOD** - Contains all hood panels and the hardware for assembling.
- **ANTI-RECYCLE TIMER** - Assures 5-minute off time between compressor cycles.
- **COIL GUARD KIT** - Guard for cooling coil.

**OTHER FACTORY INSTALLED OPTIONS**

- **POWER EXHAUST OPTION** - To work in conjunction with economizers.
- **STAINLESS STEEL HEAT EXCHANGER**
- **STAINLESS STEEL DRAIN PAN**
- **TECHNICOAT PHENOLIC COATED CONDENSER AND EVAPORATOR COIL**
- **ELECTRONIC SINGLE ENTHALPY ECONOMIZER**

- **DIRTY FILTER SWITCH**
- **PHASE MONITOR**
- **COIL GUARD**
- **POWERED GFI CONVENIENCE OUTLET**
- **NON-POWERED GFI CONVENIENCE OUTLET**
- **BAS CONTROLS** (Simplicity® Intelli-Comfort™, CPC, JOHNSON, HONEYWELL, NOVAR)
- **HINGED FILTER DOOR ACCESS AND TOOL FREE ACCESS PANELS**
- **HINGED TOOL FREE BLOWER, BLOWER MOTOR, FILTER AND ELECTRICAL ACCESS PANELS**
- **HIGH STATIC DRIVE**
- **2" THROW AWAY FILTERS**
- **4" PLEATED FILTERS**
- **DISCONNECT SWITCH**
- **SUPPLY AIR SMOKE DETECTOR**
- **RETURN AIR SMOKE DETECTOR**