



Packaged Rooftop Air Conditioning Units



10050VIP



MEA
231-02-E

50 THROUGH 130 TONS



ALLY

Nomenclature

**BASE MODEL NUMBER:
YPAL050-105**

1	2	3	4					5	6	7	8	9	10	11	12	13	14	15	16	
BASE PRODUCT TYPE																				
Y	P	A	L	0	5	0	C	0	5	0	C	B	1	7	B	D				
				: York	: 050-ton	: Cooling Only		: R-407C	: 200 / 3 / 60	: Bottom Supply										
				: Packaged Rooftop	: 055-ton	: Natural Gas Heat		: R-22	: 230 / 3 / 60	: Left Supply										
				: Air Cooled	: 060-ton	: Modulating Gas Heat			: 460 / 3 / 60	: Right Supply										
				L : Scroll	: 065-ton	: Hot Water Heat			: 575 / 3 / 60	B : Bottom Return										
					: 070-ton	: Steam Heat			: 380 / 3 / 60	R : Rear Return										
					: 075-ton				: 400 / 3 / 50	S : Side Return										
					: 080-ton															
					: 085-ton															
					: 090-ton															
					: 095-ton															
					: 105-ton															
				C : Constant Volume V : VAV, VFD F : Flexsys																

YPAL106-130

1	2	3	4					5	6	7	8	9	10	11	12	13	14	15	16	
BASE PRODUCT TYPE																				
Y	P	A	L	1	1	0	C	1	1	0	C	C	1	7	B	E				
				: York	: 106-ton	: Cooling Only		: R-22	: 200 / 3 / 60	: Bottom Supply										
				: Packaged Rooftop	: 110-ton	: Modulating Gas Heat			: 230 / 3 / 60	: Left Supply										
				: Air Cooled	: 115-ton	: Electric Heat			: 460 / 3 / 60	: Right Supply										
				L : Scroll	: 130-ton				: 575 / 3 / 60	B : Bottom Return										
									: 380 / 3 / 60	R : End Return										
									: 400 / 3 / 50											
				C : Constant Volume V : VAV, VFD F : Flexsys																

Table of Contents

Nomenclature	2	29 Component Static Pressure Drops	90
Introduction	4	30 Gas Heat Pressure Drops	96
Features and Benefits	5	31 Electric Heat Size Availability By Unit Size	98
Application Data	12	32 Electric Heat Pressure Drops	98
Physical Data	18	33 Exhaust Fan Performance	100
Cooling Performance Data	26	34 15X15 Forward-Curved Fan	100
Heating Performance Data – Gas/Electric Heat ...	86	35 18X18 Forward-Curved Fan	100
Supply Fan Data	88	36 20X18 Forward-Curved Fan	101
Component Static Pressure Drops	90	37 32" Forward-Curved Fan	101
Gas Heat Pressure Drops	96	38 Return Fan Performance	102
Electric Heat Pressure Drops	98	39 245 SWSI Airfoil Fan	102
Exhaust Fan Data	100	40 270 SWSI Airfoil Fan	102
Return Fan Data	102	41 445 Plenum Fan	103
Electrical Data	104	42 Compressor Data – R407C	104
Controls	107	43 Compressor Data – R22	105
Power Wiring	115	44 Supply and Exhaust Fan Motor	
Field Control Wiring	120	Electrical Data	105
General Arrangement Drawings	122	45 Power Supply Voltage Limits	105
Hot Water/Steam Coil Connection Locations	146	46 Condenser Fan Motors	105
Power/Control Entry Drawing	147	47 Miscellaneous Fan Data	106
Guide Specifications	149	48 Electric Heat Amp Draw	106
		49 YPAL Supply Conductor Size Range	
		50-55 Ton Units	113
		60-65 Ton Units	113
		70-75 Ton Units	113
		80-85 Ton Units	113
		90-105 Ton Units	113
		106-130 Ton Units	114
		50 Fitting Location Dimensions	146
		51 Power/Control Dimensions	147
TABLES		FIGURES	
1 Supply Air Duct Connection Configurations	13	1 Traditional Overhead VAV Air Delivery	
2 Return Air Duct Connection Configurations	13	System	14
3 Physical Data – Models 50-70	18	2 YORK FlexSys Underfloor Air Delivery	
4 Physical Data – Models 75-95	21	System	14
5 Physical Data – Models 106-130	24	3 Single-Point Power Supply Wiring	
6 Cooling Performance Data – 50 Ton Model	26	(YPAL106-130)	115
7 Cooling Performance Data – 55 Ton Model	30	4 Single-Point Power Supply Wiring with	
8 Cooling Performance Data – 60 Ton Model	34	Non-Fused Disconnect (YPAL106-130)	116
9 Cooling Performance Data – 65 Ton Model	38	5 Single-Point Power Supply Wiring	
10 Cooling Performance Data – 70 Ton Model	42	(YPAL050-105)	117
11 Cooling Performance Data – 75 Ton Model	46	6 Single-Point Power Supply Wiring with	
12 Cooling Performance Data – 80 Ton Model	50	Non-Fused Disconnect (YPAL050-105)	118
13 Cooling Performance Data – 85 Ton Model	54	7 Dual Point Power Supply Wiring	
14 Cooling Performance Data – 90 Ton Model	58	(YPAL050-105)	119
15 Cooling Performance Data – 95 Ton Model	62	8 Field Control Wiring	120
16 Cooling Performance Data – 105 Ton Model ..	66	9 Field Control Wiring	121
17 Cooling Performance Data – 106 Ton Model ..	70	10 General Arrangement Drawing	122
18 Cooling Performance Data – 110 Ton Model ..	74	11 Power/Control Entry Drawing	147
19 Cooling Performance Data – 115 Ton Model ..	78		
20 Cooling Performance Data – 130 Ton Model ..	82		
21 Gas Heat Performance Data	86		
22 Electric Heat Performance Data	86		
23 25X22 Forward Curved Fan	88		
24 25" Airfoil Fan	88		
25 28X25 Forward Curved Fan	88		
26 28X28 Forward Curved Fan	89		
27 32" Airfoil Fan	89		
28 40" Airfoil Fan	89		

Introduction

The eco² packaged rooftop – Designed to meet the demands of the market for today and tomorrow.

Better Economy...

Lower total cost of ownership

- High efficiency eco² rooftop units are optimized for HCFC-22 refrigerant. YORK provides the FIRST standard product offering that meets the latest ASHRAE 90.1 energy efficiency requirements.
- Fully modulating gas heat and greater steps of capacity control offer superior off-design performance while maintaining optimum occupant comfort.
- Accurate ventilation control ensures that no more than the proper amount of ventilation air is utilized. This avoids the energy cost of conditioning excess outside air and simultaneously monitors all other unit functions for maximized energy efficiency.
- Flexible design configurations simplify the design process and allows the Eco² to be applied to virtually any building application.
- Accessibility through double-wall access doors, spacious compartments and supportive floors improves serviceability.

Better Ecology...

Indoor air quality features for the indoor environment

- A double-sloped stainless steel drain pan with a single drain connection ensures that all condensate is voided from the drain pan. It is also visible and accessible for periodic inspection and cleaning required by the ASHRAE 62 IAQ standard.
- Double-wall construction of the roof, floor, doors, and walls prevents insulation fibers from entering the conditioned air. The inner liner also facilitates periodic cleaning of the unit to prevent harmful build-up of bacteria or contaminants.
- The rooftop unit control center uses microprocessor logic to analyze and optimize ventilation decisions and perform demand ventilation, airflow compensation, and airflow measurement to maintain the air quality at a healthy level.



The Rooftop Unit Control Center uses microprocessor logic to optimize operation of the eco² rooftop unit.

Features and Benefits

AIRFLOW CONFIGURATIONS

Variable-Air-Volume – Eco² units are available for single-zone variable-air-volume (VAV) applications. Control can be used with a zone sensor or building automation system. Supply fans are controlled to the supply duct static pressure setpoint, which can be reset via a BAS, or through a 0-5VDC analog input on the unit controller for optimized duct static pressure control. The static pressure transducer is provided in the rooftop unit, and 5/16" or 1/4" plastic tubing and static pressure sensor must be supplied by others and installed approximately 3/4 down the longest duct run.

FlexSys Underfloor Air VAV – Eco² units are configurable for underfloor air variable-air-volume (VAV) applications. Control can be used with a zone sensor or building automation system. Supply fans are controlled to the supply duct static pressure setpoint, which can be reset via a BAS, or through a 0-5VDC analog input on the unit controller for optimized duct static pressure control. The static pressure transducer is provided in the rooftop unit, and 5/16" or 1/4" plastic tubing and static pressure sensor must be supplied by others and installed approximately 3/4 down the longest duct run. *Refer to engineering guide form 100.50-EG2 for more detailed information on this application.*

Constant Volume – Eco² units are available for single-zone constant volume applications. Control can be used with a zone sensor, thermostat, or building automation system.

COOLING AND HEATING CONFIGURATIONS

Cooling Only – For applications where no heat is required, or heating is provided elsewhere within the building HVAC system, cooling only units include an empty discharge plenum. Supply duct connections are configurable for bottom, left or right discharge. The supply air temperature sensor is included and factory-installed.

Staged Gas Heat – For applications requiring gas heat for morning warm-up, or other heating needs, a staged natural gas furnace is available. The furnace is located in the discharge plenum, downstream of the supply fan. The supply air temperature sensor is located across the face of the supply duct opening in the unit. Furnaces are designed in 375 mbh modules with two stages in each. Two are available on the YPAL050-065 and three for the YPAL070-130. Ignition and safety controls are included and factory-wired. Units with modulating gas heat are UL listed.

Modulating Gas Heat – For applications requiring gas heat for morning warm-up, supply air tempering or other

heating needs, a modulating natural gas furnace is available for finer temperature control. The furnace is located in the discharge plenum, downstream of the supply fan. The supply air temperature sensor is located across the face of the supply duct opening in the unit. Furnaces are designed in 375 mbh modules in 8:1 turn-down increments. Two are available on the YPAL050-065 (8:1 or 16:1 turndown) and three for the YPAL070-130 (8:1, 16:1 or 24:1 turndown). Ignition and safety controls are included and factory-wired. Units with modulating gas heat are UL listed.

Electric Resistance Heat – For applications where electric heat is desired, a slip-in electric resistance heat element is available in sizes from 40-250 kW depending on the rooftop model size. The number of stages varies by size and voltage, but all have a minimum of two stages of capacity. Units with electric heat are ETL listed.

Hot Water Heat – For applications where hot water is available for heating, a hot water heating coil is available. A range of coil fin count selections are available to properly size the heating for the application. Two-or-three-way control valves are available from YORK in a variety of sizes, and are shipped loose for field installation. Units with hot water heat are ETL listed.

Steam Heat – For applications where steam is available for heating, a steam heating coil is available. A range of coil fin count selections are available to properly size the heating for the application. Two-way control valves are available from YORK in a variety of sizes, and are shipped loose for field installation. Units with steam heat are ETL listed.

POWER OPTIONS

Single-point supply with terminal block – This configuration is standard, and includes three terminals for the incoming 3-phase power and is the standard configuration for the Eco² product. It includes the enclosure, terminal-block, and interconnecting wiring to the compressors, heater and furnace controls, all fans, etc. In this configuration, code requires that a means of disconnect (not provided) must be installed at the site within line-of-sight of the equipment.

Single-point supply with non-fused disconnect switch – This option is the same the single-point with terminal block option except it includes a unit-mounted through-the-door manual non-fused disconnect switch with an external, lockable handle (in compliance with Article 440-14 of N.E.C.). This option provides a means to isolate the unit power voltage for servicing. Others must supply separate external fusing which must comply with the National Electric Code and/or local codes.

Features and Benefits (continued)

Dual-point supply with terminal block – This option includes enclosure, terminal blocks circuited to the supply and exhaust fans and control transformer and a second set of terminal blocks with interconnecting wiring to the compressors, heat (if applicable) and condenser.

Convenience Outlet – This options includes a powered 115V GFCI convenience outlet that can be used for powering tools or lights for servicing. A protective cover plate is included while not in use. The outlet is located on the bottom left hand corner of the power panel.

CONTROL FEATURES AND OPTIONS

Microprocessor-Based Rooftop Unit Controller – All Eco2 units are equipped with a factory-installed, programmed and commissioned unit controller with all I/O capabilities and control sequences. The controls include all on-board diagnostic, safety and control features to operate the rooftop unit. A multimedia card interface is included for software upgrades and can be used for data logging to simplify equipment troubleshooting. Communication ports are included as standard with three alarm outputs, a shutdown contact, remote start/stop input, smoke ventilation controls, analog inputs for supply air temperature and duct static pressure rest, along with a variety of other capabilities.

Standard Ambient – YPAL050-105 models operate down to 45°F as standard. YPAL106-130 models operate down to 0°F as standard.

Low Ambient – (YPAL050-105) This option includes low ambient control of the first refrigerant circuit down to 0°F through the use of suction and discharge pressure transducers on circuit one, and condenser fan speed using a variable-frequency drive on the first condenser fan of circuit one. Mechanical cooling with circuit two (and three for YPAL070-105) is locked out below 45°F.

Low Ambient on Circuits One and Two – This option includes low ambient control of the first and second refrigerant circuit down to 0°F through the use of suction and discharge pressure transducers on both circuits, and a variable-frequency drive on the first condenser fan of each circuit. This option applies to YPAL050-065 models. On YPAL070-105 models, mechanical cooling with circuit three is locked out below 45°F.

Low Ambient on Circuits One, Two and Three – (YPAL070-105) This option includes low ambient control of the first, second and third refrigerant circuits down to 0°F through the use of suction and discharge pressure transducers on both circuits.

Pressure Transducers with Readout Capability – This option includes suction and discharge pressure transducers on each circuit and provides pressure readout of all circuits at the unit control panel.

SENSOR AND THERMOSTAT AND SENSOR OPTIONS

Wall-Mount Zone Sensor – a 1 kOhm thin-film nickel zone sensor for wall mounting. This zone sensor is for sensing temperature only, and does not include any setpoint adjustment features.

7-Wire Thermostat – This option is for a ship-loose thermostat to interface with the Eco² unit. All models, YPAL050-130, include an interface for a 7-wire thermostat as standard.

COMMUNICATIONS

BACnet MSTP (RS-485) Communications – This communication option is standard on every Eco² unit. Communications to the unit are through a twisted pair, and the wire terminations are on the primary unit control board. See supplemental information for the available control points and PICS/Bibbs statements of conformity.

Modbus RTU Communications – This communication option is standard on every Eco² unit and can be used in lieu of the BACnet communications (only one can be used at a time). See supplemental information for the available control points.

FILTER OPTIONS

Filter Options – two-inch throwaway, cleanable, carbon or pleated filters in an angled rack are available. For higher filtration requirements, optional rigid filter racks are available with twelve-inch 65% or 95% efficient rigid filters. Two-inch pre-filters are included with rigid filter options. The rigid filter rack option is available without filter media where field-supplied filters are required.

OUTSIDE AIR DAMPER OPTIONS

Manual Damper – This option includes a manually adjustable outside air damper. It is manually adjustable at the unit by setting a mechanical stop between 0-100 percent.

Two-Position – This outside air damper option is controlled to a two positions, opened and closed. Determination of the damper position is based on the occupancy schedule. In the occupied mode, the outside air

damper is positioned to the manually configured point (set by mechanical stop). In the unoccupied mode, the damper is fully closed.

Modulating Economizer – This option includes modulating outdoor air and return air dampers that are interlocked (YPAL050-065 mechanical interlock, YPAL070-130 software interlock) and positioned by fully modulating, solid state damper actuators. Control of the damper is via a standard ambient outdoor air dry bulb sensor, or optional single or comparative enthalpy controls.

Airflow Measurement – Optional outside airflow measurement is available on units equipped with a Modulating Economizer. Two options exist for airflow measurement; minimum (0-25%) and full (0-100%) .

CO₂ Sensors – Optional carbon dioxide sensors for occupied space that operate demand ventilation control opening outside air dampers to ventilate building. The CO₂ sensors can operate in a single or comparative control scheme.

Rain Hoods on Outside Air Intakes – For all options with outside air intake openings, rain hoods are provided as standard to keep moisture from entering the equipment. Rain hoods as an integral part of the unit and are rotated into place.

RELIEF SYSTEM

Barometric Relief – Optional building air exhaust shall be accomplished through barometric relief dampers installed in the return air plenum. The dampers will open relative to the building pressure. The opening pressure shall be adjustable via a spring tension adjustment.

On/Off Powered Exhaust – This option provides simple building pressure control. It can be controlled via a building pressure signal, or via outside air damper control. ***This option is not available for VAV units.***

Modulating Powered Exhaust with Damper Control – This option consists of a constant-speed exhaust fan with a discharge damper that is modulated to control the flow of exhaust air. The damper control logic is based on the building static pressure setpoint within the rooftop unit controller. The static pressure transducer is provided in the return plenum of the rooftop unit, and 5/16" or 1/4" plastic tubing and static pressure sensor must be supplied by others and installed in a representative location in the building.

Modulating Powered Exhaust with a VFD – This option consists of a VFD to modulate the speed of the exhaust fan to control the flow of exhaust air. The VFD control logic is based on the building static pressure setpoint within the rooftop unit controller. The static pressure transducer is provided in the return plenum of the rooftop unit, and 5/16" or 1/4" plastic tubing and static

YORK INTERNATIONAL

pressure sensor must be supplied by others and installed in a representative location in the building.

Powered Return Fan with Exhaust – This option uses SWSI plenum fan(s) to control building pressure. The fan motors are driven by a VFD to maintain a constant return plenum pressure. An exhaust hood with a modulating control damper is used to maintain building pressure via the building static pressure. The static pressure transducer is provided in the return plenum of the rooftop unit, and 5/16" or 1/4" plastic tubing and static pressure sensor must be supplied by others and installed in a representative location in the building. The powered return fan is also available without the exhaust capabilities. For units with no exhaust capabilities, the HVAC system must provide alternate means of controlling building pressure.

SUPPLY FAN OPTIONS

DWDI Forward-Curved Supply Fan – The standard supply air blower in the YPAL050-105 models is a forward-curved supply fan. This fan is good for medium static pressures and high airflows.

DWDI Airfoil Supply Fan – An optional airfoil blade supply fan is available on all models for higher static conditions. This option offers higher efficiency and lower sound in certain applications.

Fan Skid Isolation – the entire supply fan assembly is isolated from the unit base with two-inch deflection springs, or one (standard) or two-inch deflection springs with seismic restraints.

Supply and Exhaust Fan Motors – high efficiency ODP, and standard and high efficiency TEFC motors are available all meeting the Energy Policy Act of 1992 (EPACT).

Supply Fan VFD and Manual Bypass – for VAV applications, VFD's are provided to modulate air flow. Optional manual bypass can also be provided to allow full airflow in the event of a VFD failure.

EVAPORATOR SECTION

Double Sloped Stainless Steel Drain Pan – The Eco²'s stainless steel drain pan is factory-mounted and installed on every unit. A condensate drain trap is needed, and must be provided and installed in the field by others.

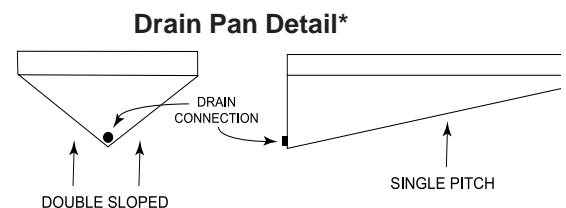

***NOTE:**

This is a visual reference only. Actual drain pan pitch will vary.

LD08022

Features and Benefits (continued)

Double Wall Construction – Double-wall construction is the standard construction of the Eco2 and incorporates powder coated pre-fabricated outer panels and corner post for maximum exterior surface protection.

Factory Shrink-wrap – All Eco² rooftop units are shipped from the factory with factory-fresh shrink-wrap packaging. No longer does the contractor need to worry about dirt and debris clogging up condenser coils or moisture leaking into the air handler on the units way to the job site or rigging yard.

Copper Fins – For more extreme climates that aggressively can attack aluminum, copper tube condenser coils with copper fins are available. (This is not recommended for units in areas where they may be exposed to acid rain or environments where ammonia is present)

CONDENSER FEATURES AND OPTIONS

Scroll Compressors – Reliable, efficient, trouble-free operation is the true measure of a packaged rooftop's value. That's why YORK eco² Packaged Rooftop Air Conditioners use established scroll compressor technology to deliver dependable, economical performance in a wide range of applications. With the eco² Packaged Rooftop, you get the latest generation of compressor enhancements added to the scroll's inherent strengths. The simplicity of a hermetic scroll compressor allows the use of fewer moving parts to minimize breakdown. HFC-407C is available on select models for applications requiring non-ozone-depleting refrigerants.

Multiple Compressor Staging – Through the use of the scroll compressor, the eco² has the ability to stage it's cooling by enabling and disabling multiple single stage compressors on multiple circuits.

These compressors are manifolded together in pairs on a single refrigeration circuit and depending on the size of the unit, it may have 2, 3 or even 4 refrigeration circuits operating a dual manifolded scroll compressor set.

Compressor Circuiting – the eco² is designed so that only 2 scroll compressors are in tandem within one refrigeration circuit. This means more reliable compressors, and less equipment down time. With multiple circuits, if a compressor should ever fail on one circuit, the other circuit/s will remain operational to work to maintain occupied loads. The Eco2 system can have 2 to 3 circuits in a unit, depending on the size of the unit.

Condenser Fan Motors – The condenser fan motors used on the Eco² unit are Totally Enclosed Air Over (TEAO) to provide maximum durability through any season.

Hot Gas Bypass – This options permits continuous, stable operation at capacities below the minimum step of unloading by introducing an artificial load on the evaporator. For models YPAL050-105, it is used on the lead circuit. For models YPAL106-130 it is available on the first, or all circuits.

Replaceable Core Suction Line Driers – suction line driers are standard on the Eco² rooftop unit. An option is provided for replaceable core driers (standard on YPAL106-130)

Copper Fins – For more extreme climates that aggressively can attack aluminum, copper tube condenser coils with copper fins are available. (This is not recommended for units in areas where they may be exposed to acid rain or environments where ammonia is present)

Pre-Coated Fins – an epoxy-coated aluminum fin stock to guard from corrosive agents and insulate against galvanic potential. Recommended for mild seashore or industrial locations.

Post-Coated Fins – Technicoat coil-coating process used on condenser coils for seashore and other corrosive applications (with the exception of strong alkalis, oxidizers, wet bromide, chlorine and fluorine in concentrations greater than 100ppm).

Compressor Sound Blankets – Optional compressor acoustic sound blankets are available for sound sensitive applications.

ROOF CURBS

Full perimeter roof curbs – This option includes a knock-down 14" high roof curb for use with wood nailer (by others). Roof curb supports the entire perimeter of the unit.

Partial perimeter roof curbs – This option includes a knock-down 14" high roof curb for use with wood nailer (by others). Roof curb supports the air handling section with a separate support under the condenser end.

CABINET FEATURES AND OPTIONS

Double-Wall Access Doors - Full-sized access doors provide easy access into the unit for routine maintenance and inspection. Solid wall liners encase insulation and prevent damage and erosion into the airstream.

Diffuser Section – An optional diffuser section is available downstream of the supply fan in the extended discharge plenum cabinet option. The diffuser section distributes the airflow from the fan evenly across the downstream filter bank to optimize filter life and effective-

ness. The diffuser design is optimized to provide uniform flow at minimal airside pressure loss.

Downstream Final Filter Rack – A 90-95% efficient twelve-inch rigid filter rack and filters shall be provided downstream of the supply fan and diffuser segment for hospital applications (YPAL050-105 only). A magnahelic pressure gauge is included and visible from the outside of the unit for servicing and code compliance.

Blank Section – A blank section shall be provided downstream of the supply fan and diffuser section (YPAL050-105 only).

ACCESSORIES

Filter Switch – An optional dirty filter alarm can be provided that will provide an alarm when the filters require cleaning.

Magnahelic Filter Pressure Gauge – On units equipped with downstream filtration, a magnahelic filter gauge is included and visible on the exterior of the unit. The filter gauge measures the air pressure drop for through the rigid filter bank to indicate when replacement is required.

Features and Benefits (continued)

YPAL050-105 MODEL

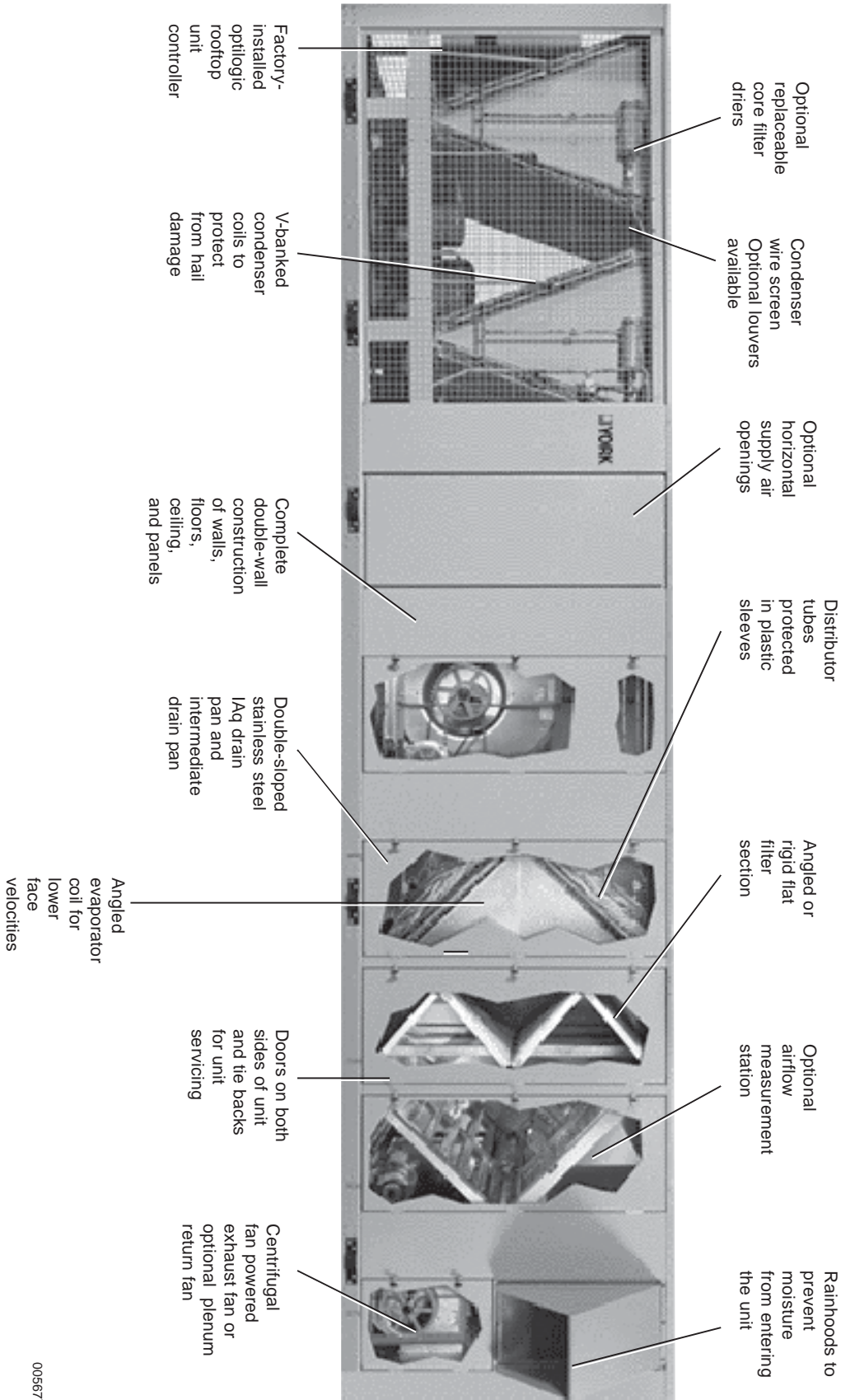

Optional
replaceable
core filter
driers

Condenser
wire screen
Optional louvers
available

Optional
horizontal
supply air
openings

Distributor
tubes
protected
in plastic
sleeves

Angled or
rigid flat
filter
section

Optional
airflow
measurement
station

Rainhoods to
prevent
moisture
from entering
the unit

Factory-
installed
optilogic
roof top
unit
controller

V-banked
condenser
coils to
protect
from hail
damage

Complete
double-wall
construction
of walls,
floors,
ceiling,
and panels

Double-sloped
stainless steel
lag drain
pan and
intermediate
drain pan

Angled
evaporator
coil for
lower
face
velocities

Doors on both
sides of unit
and the backs
for unit
servicing

Centrifugal
fan powered
exhaust fan or
optional plenum
return fan

00567VIP

YPAL106-130 MODEL

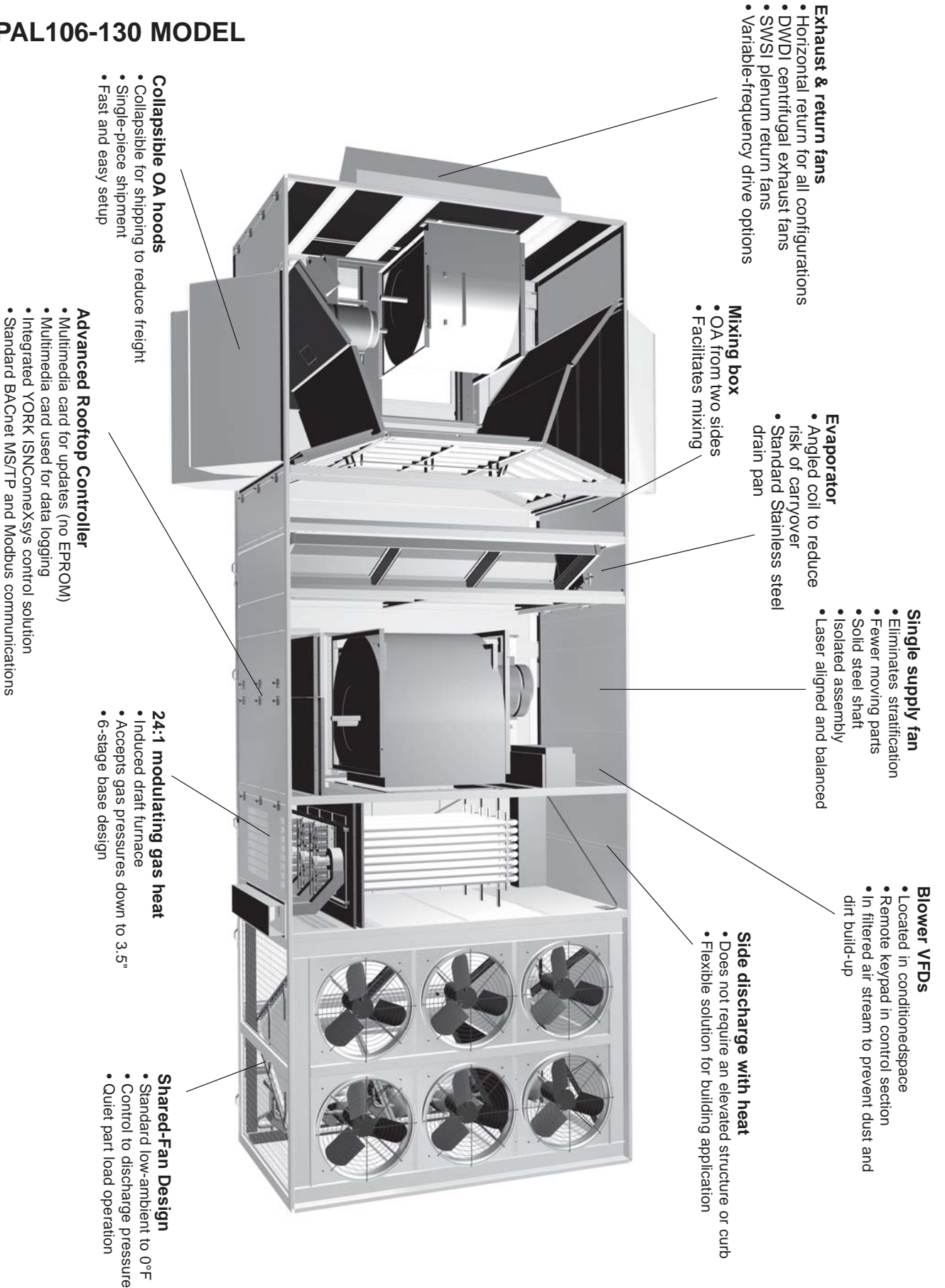

- Exhaust & return fans**
- Horizontal return for all configurations
 - DWDI centrifugal exhaust fans
 - SWSI plenum return fans
 - Variable-frequency drive options

- Evaporator**
- Angled coil to reduce risk of carryover
 - Standard Stainless steel drain pan
- Mixing box**
- OA from two sides
 - Facilitates mixing

- Single supply fan**
- Eliminates stratification
 - Fewer moving parts
 - Solid steel shaft
 - Isolated assembly
 - Laser aligned and balanced

- Blower VFDS**
- Located in conditionedspace
 - Remote keypad in control section
 - In filtered air stream to prevent dust and dirt build-up

- Side discharge with heat**
- Does not require an elevated structure or curb
 - Flexible solution for building application

- Collapsible OA hoods**
- Collapsible for shipping to reduce freight
 - Single-piece shipment
 - Fast and easy setup

- Advanced Rooftop Controller**
- Multimedia card for updates (no EPROM)
 - Multimedia card used for data logging
 - Integrated YORK ISNConneXsys control solution
 - Standard BACnet MSTP and Modbus communications

- 24:1 modulating gas heat**
- Induced draft furnace
 - Accepts gas pressures down to 3.5"
 - 6-stage base design

- Shared-Fan Design**
- Standard low-ambient to 0°F
 - Control to discharge pressure
 - Quiet part load operation

Application Data

GENERAL

The eco² air conditioning units are designed for outdoor installation. When selecting a site for installation, be guided by the following conditions:

- Unit must be installed on a level surface.
- For the outdoor location of the unit, select a place having a minimum sun exposure and an adequate supply of fresh air for the condenser.
- Also avoid locations beneath windows or between structures.
- Optional condenser coil protection should be used for seashore locations or other harsh environments.
- The unit should be installed on a roof that is structurally strong enough to support the weight of the unit with a minimum of deflection. It is recommended that the unit(s) be installed not more than 15 feet from a main support beam to provide proper structural support and to minimize the transmission of sound and vibration. Ideally, the center of gravity should be located over a structural support or building column.
- Location of unit(s) should also be away from building flue stacks or exhaust ventilators to prevent possible reintroduction of contaminated air through the outside air intakes.
- Be sure the supporting structures will not obstruct the duct, gas or wiring connections.
- Proper service clearance space of 6-feet around the perimeter of the unit, 8-feet on one side for coil servicing, and 12-feet to any adjacent units is required to eliminate cross contamination of exhaust and outdoor air, and for maintenance tasks such as coil pull and cleaning. No obstructions should be above the condensing unit section.

LOCATION

Of the many factors that can effect the location of equipment, some of the most important to consider are Structural, Acoustical and Service clearances. Proper attention should be made at the design stage to ensure proper structural support. In cases where equipment is being replaced, be aware of building design to insure support is adequate for the application.

The next most important consideration in applying roof top equipment is that of sound from the equipment. Special care should be made to keep the roof top unit away from sound sensitive areas such as conference rooms, auditoriums and executive offices and any other room that may have potential for tenant occupancy. Possible locations could be above hallways, mechanical or utility rooms.

Finally, service clearances should be maintained in roof-top design to insure safe access to the unit. Unit clearances are designed so that technicians have enough space between units, building walls, and edges of building to gain access safely. In cases where space is limited, please call your local York representative for additional information.

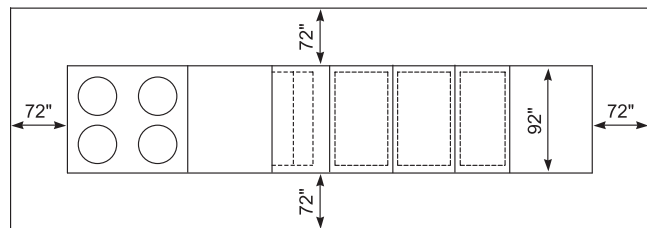

LD08044

RIGGING

Proper rigging and handling of the equipment is mandatory during unloading and setting it into position to retain warranty status.

Spreader bars must be used by cranes to prevent damage to the unit casing. All lifting lugs must be used when lifting the rooftop unit. Fork lifts will damage the rooftop unit and are not recommended.

Care must be taken to keep the unit in the upright position during rigging and to prevent damage to the water-tight seams in the unit casing. Avoid unnecessary jarring or rough handling.

UNIT PLACEMENT

- **Elevated** – Elevated roof curbs or dunnage steel can be used to support the unit in order to raise it to specific heights. When this type of placement is required, be sure to keep unit access in mind. Cat walks or other forms of unit access may be required to one or both sides of the unit, depending on your area of the country and the local codes that are enforced. Please check with local officials to ensure the application conforms to local codes and regulations.
- **Ground Level Locations** – It is important that the units be installed on a substantial base that will not settle, causing strain on the refrigerant lines and sheet metal and resulting in possible leaks. A one-piece concrete slab with footers extended below the frost line is highly recommended. Additionally, the slab should be isolated from the main building foundation to prevent noise and vibration transmission to the building structure.

For ground level installations, precautions should be taken to protect the unit from tampering by, or

injury to, unauthorized persons. Erecting a fence around the unit is common practice.

- **Roof curb** – YORK offers optional roof curbs designed specifically for the eco² footprint. These curbs come in full perimeter or open condenser models and are shipped disassembled and require field assembly and installation. For bottom supply and return openings, the curbs have matching connections to ease installation. A pipe chase that matches the rooftop unit pipe chase is also included in the curb footprint for through-the-curb utility connections.

The curb should be located according to the location recommendations above, and properly sealed to prevent moisture and air leakage into and out of the duct system. Flexible collars should be used when connecting the duct work to prevent unit noise transmission and vibration into the building.

Duct work should be supported independently of the unit.

TABLE 1: SUPPLY AIR DUCT CONNECTION CONFIGURATIONS

Unit Configuration		Supply Air		
		Bottom	Left	Right
YPAL 050-065	Standard Cabinet			
	Cooling only	X	X	X
	Cool/gas heat	X	X	
	Cool/electric heat	X		
	Cool/hydronic heat	X		
	Extended Cabinet			
Cooling only	X	X	X	
Cool/hydronic heat	X	X	X	
YPAL 070-105	Standard Cabinet			
	Cooling only	X	X	X
	Cool/gas heat	X	X	
	Cool/electric heat	X		
	Cool/hydronic heat	X		
	Extended Cabinet			
Cooling only	X	X	X	
Cool/hydronic heat	X	X	X	
YPAL 106-130	Standard Cabinet			
	Cooling only	X	X	X
	Cool/electric heat	X		
	Cool/gas heat	X	X	

NOTE:

1. Under certain conditions these clearances may be encroached upon.
2. This is a visual reference for all eco² units.

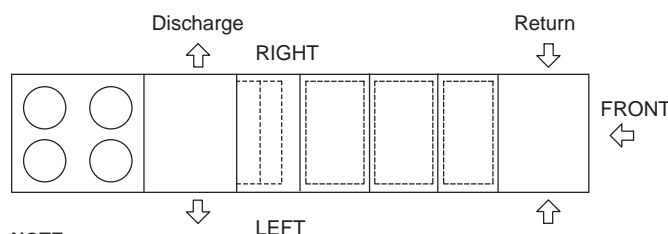

NOTE:

This diagram is provided as a visual reference of the eco² discharge & return air openings & locations for all sizes. Please refer to the dimensional data for exact size & location of panels and openings.

TABLE 2: RETURN AIR DUCT CONNECTION CONFIGURATIONS

Unit Configuration		Return Air			
		Bottom	Left	Right	Front
YPAL 050-065	No exhaust	X			X
	Barometric relief damper	X			
	Powered exhaust fan (all types)	X			
	Powered return fan	X			Not available
YPAL 070-105	No exhaust	X	X	X	X
	Barometric relief damper	X	X	X	
	Powered exhaust fan (all types)	X	X	X	
	Powered return fan	X			
YPAL 106-130	No exhaust	X			X
	Barometric relief damper	X			X
	Powered exhaust fan (all types)	X			X
	Powered return fan	X			X

DUCT CONSIDERATIONS

Unlike competitive units where air can leave the rooftop unit stratified across the width of the unit, the Eco2 unit sufficiently mixes airflow to ensure consistent air temperature from the unit. No special Tee considerations are required and the unit may be oriented either way.

UNIT ORIENTATION

For applications with multiple rooftop units located in close proximity on the roof, the orientation of the unit may be important to reduce the potential for re-entrainment of outside airflow. Regardless of the outside air and exhaust air openings on a unit, all rooftop applications can permit recirculation of exhaust air to the return, if applied improperly.

HORIZONTAL APPLICATIONS

The spectrum of applications for roof top units in today's market is continuing to grow wider by the day. Flexibility in unit design and construction is a must in today's market in order to insure safe and sound applications of HVAC equipment. The eco² has been designed for specific application of horizontal supply and return airflow taking the guess work out of unit application by building a

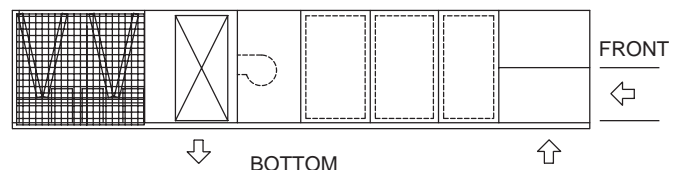

Application Data (continued)

unit specific to these needs. If the application calls for horizontal supply and return air, YORK can ship it from the factory as a horizontal unit. This option elevates the need for field modification of equipment saving time and money. The eco² can support a left discharge on all units and/or right discharge on all cooling only units and hydronic heat units with an extended cabinet. Return air can be brought through the end or side return air inlet making the unit specific to building needs.

ECONOMIZER

The economizer section is used for ventilation of the conditioned space to maintain indoor air quality, and also to reduce energy consumption by using outdoor air cooling in lieu of mechanical cooling. If outdoor air is appropriate for cooling, but not sufficient for the cooling demand, mechanical cooling will stage on as necessary until the cooling load is met.

Dual (comparative or differential) enthalpy operation is the most accurate and efficient means of economizer operation. The OptiLogic™ control monitors the return and outside air energy content, and selects the lower of the two for operation.

VAV SUPPLY AIR PRESSURE CONTROL

Traditional packaged rooftop systems use inlet guide vanes (IGVs) for duct static pressure control. These control supply duct pressure by modulating dampers (introducing losses and inefficiencies) on the inlet of the fan, open and closed. YORK's variable frequency drives (VFDs) offer superior fan speed control and quieter, energy efficient operation.

For VAV applications, the YORK eco² unit uses a VFD to modulate fan speed and maintain a constant duct static pressure. VFDs offer superior control over the

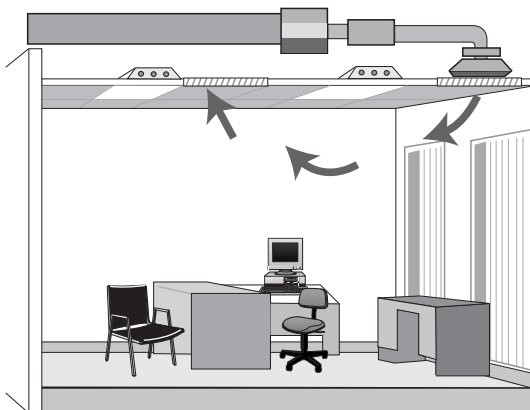

FIG 1: TRADITIONAL OVERHEAD VAV AIR DELIVERY SYSTEM

operation of the unit at part load, and offer the additional benefits of quieter and more efficient operation when compared to IGVs.

FLEXSYS

The traditional approach to HVAC design in commercial buildings has been to supply conditioned air through extensive overhead duct networks to an array of diffusers spaced evenly in the ceiling. In Figure 1, the conditioned air is both supplied and returned at ceiling level. Ceiling plenums must be designed large enough to accommodate the supply ducts that run through them. Return air is typically configured as ceiling plenum return without any ductwork. This type of air distribution, known as the "well-mixed" type, is the most common system in use. This conventional HVAC system is de-

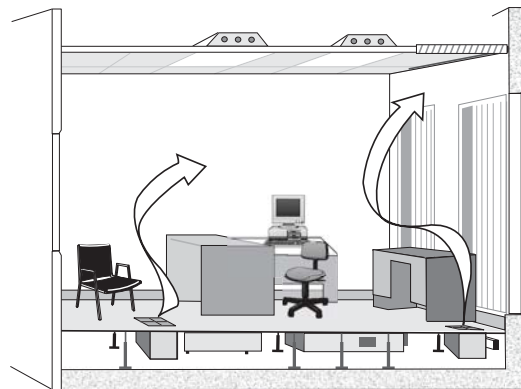

FIG. 2: YORK FLEXSYS UNDERFLOOR AIR DELIVERY SYSTEM

signed to promote complete mixing of supply air with room air, thereby maintaining the entire volume of all air in the space (from floor to ceiling) at the desired space setpoint temperature. In addition, to meet IAQ requirements, an adequate supply of fresh outside air must be introduced to this mix. A key disadvantage to this control strategy is that it has no provisions to accommodate different temperature preferences among the building occupants or to provide preferential ventilation in the occupied zone.

With the YORK FlexSys Underfloor Air System, conditioned air from the air handling unit (AHU) is ducted to the underfloor plenum. As shown in Figure 2, this conditioned air flows freely throughout the plenum to individual supply discharge outlets. Unlike the larger single supply duct outlets typical of overhead systems, underfloor systems are configured to have a large number of smaller supply outlets, in close proximity to the building occupants. These adjustable outlets provide an opportunity for nearby occupants to have some amount of control over thermal comfort conditions in

their local environment. Air is returned from the room at ceiling level (unducted plenum return is shown). The resulting overall floor-to-ceiling air flow pattern takes advantage of the natural buoyancy produced by heat sources in the space and more efficiently removes heat loads and contaminants from the space, particularly for cooling applications. In fact, some of the most important advantages of underfloor systems over ceiling-based systems occur during cooling conditions, which are required year-round in the vast majority of interior office space in many parts of the United States.

HARSH ENVIRONMENTS – CONDENSER AND EVAPORATOR COIL PROTECTION

For harsh environmental conditions such as seashore applications, YORK offers three types of coil protection: copper fin material, black fin and Technicoat coatings. YORK recommends that for corrosive environments that copper fins be used to protect the evaporator and/or condenser coils. In areas where chemicals that can corrode copper are present, such as ammonia, YORK recommends that the black fin or Technicoat coating be used for maximum protection.

- **Copper Fin Condenser Coil** – Copper fins can be used instead of aluminum for additional corrosion protection, however it is not suitable for areas that are subject to acid rain or exposed to ammonia.
- **Pre-Coated Condenser Fins** – Black fin coating (yellow fin for evaporator fins) is pre-coated application epoxy on aluminum fin stock to guard from corrosive agents and insulate against galvanic potential. It is used for mild seashore or industrial locations. This can provide corrosion resistance comparable to copper fin coils in typical seashore locations.
- **Post-Coated Condenser Fins** – Technicoat (a post-coated application of epoxy) can be used for seashore and other corrosive applications with the exception of strong alkaloids, oxidizers, wet bromide, chlorine and fluorine in concentrations greater than 100 ppm.

Any of the above suitable options should be selected based on the particular project design parameters and related environmental factors. The application should be further reviewed and approved by the consulting engineer or owner based on their knowledge of the job site conditions.

BUILDING PRESSURE CONTROL SYSTEMS

Building pressure control systems are often necessary when economizers are used to bring in outdoor air. Without proper building exhaust, the building may become over pressurized. The pressure control system maintains the proper building pressure by expelling the

appropriate amount of air from the building.

Return fans – For high return static applications, such as buildings with ducted return systems, a powered return fan may be necessary to maintain building pressure control. York offers a powered return fan that is located in the return plenum. This fan operates coincidentally with the supply fan and draws return air back through the return ductwork and into a pressurized plenum. A control damper modulates to exhaust air out of the building and maintain the building pressure. A second control damper modulates to provide return air from the ductwork to the unit to the rooftop air mixing section.

The return fan configuration is available in two forms: with and without an exhaust damper. The option with the exhaust damper provides a means of building exhaust at the unit. In some applications, the exhaust system is located elsewhere and the rooftop unit is not required to provide building exhaust. In these situations, the Eco2 can be offered without the exhaust damper to help reduce installed costs.

Exhaust/relief fans – In this application, a powered exhaust fan may be suitable, however careful consideration of the fan type is necessary. York offers a centrifugal powered exhaust fan to perform this function. Some manufacturers use a propeller exhaust fan, which cannot handle the static pressure requirements.

For systems with moderate to low return static pressure, an exhaust fan is recommended. The benefit of the exhaust fan is that it does not run all of the time, and may facilitate compliance with the ASHRAE 90.1 fan motor horsepower requirement.

The exhaust fan operates in parallel with the supply fan. In this arrangement, the supply fan handles the full static pressure requirements of the system. For normal building pressure control, the exhaust fan operates to draw air from the return plenum and exhaust it out of the building.

The exhaust fan configuration is available in two forms, modulating and non-modulating. Modulating is the most common and recommended for the majority of applications, while non-modulating should be used with in only certain circumstances.

In the modulating exhaust system, the volume of airflow exhausted from the building is proportional to the entering volume of outside air. Control is accomplished via either a discharge damper or a variable-frequency-drive (VFD). York recommends the use of a VFD to reduce energy consumption, sound levels and improved reliability due to fewer moving parts.

In the non-modulating exhaust system, the exhaust airflow is constant whenever the exhaust fan is operating. This type of control should only be used to either assist

Application Data (continued)

a smoke purge system or when a system requires a constant volume of exhaust airflow.

ACOUSTICAL CONSIDERATIONS

The eco² unit is designed for lower sound levels than competitive units by using flexible fan connections, fan spring isolators, double-wall construction, multiple fan options, and lower speed and horsepower fans. For VAV applications, VFDs are used instead of inlet guide vanes. Additional sound attenuation can be obtained using compressor sound blankets and field-supplied sound attenuators when necessary.

Even with these equipment design features, the acoustical characteristics of the entire installation must never be overlooked. Additional steps for the acoustical characteristics of a rooftop installation should be addressed during the design phase of a project to avoid costly alterations after the installation of the equipment. During the design phase of a project, the designing engineer should consider, at a minimum, the impact of the equipment location, rooftop installation, building structure, and duct work. For sound sensitive projects, refer to the YORK sound application guide, Form 100.00-AG1.

This page intentionally left blank

Physical Data

TABLE 3 – PHYSICAL DATA – MODELS 50-70

MODEL SIZE	50	55	60	65	70
GENERAL DATA					
Standard cabinet length without hoods (inches)	344	344	344	344	454
Extended cabinet length without hoods (inches)	389	389	389	389	517
Width (Inches)	92	92	92	92	92
Height (Inches)	82	82	82	82	82
Weights (Lbs.) (base unit, no option)					
Base cabinet, cooling only with economizer	8282	8394	8607	8703	11,951
Extended cabinet, cooling only with economizer	9126	9238	9451	9547	13,161
Option Weights (Lbs.)					
Power Exhaust (Blower, mtr, mtr base, fan skid, mod damper & hood)	685	685	685	685	1045
Power Exhaust (Blower, mtr, mtr base, fan skid, VFD, baro damper & hood)	692	692	692	692	1044
100% AMS (Measurement Station & Mounting)	110	110	110	110	125
25/75% AMS (Measurement Station & Mounting)	130	130	130	130	146
Min. AMS (Measurement Station & Mounting)	40	40	40	40	45
Barometric only	36	36	36	36	45
375 MBH Gas Heat	162	162	162	162	162
750 MBH Gas Heat	324	324	324	324	324
1050 MBH Gas Heat	n/a	n/a	n/a	n/a	486
40 kW/415/3/60 or 40 kW/480/3/60 2 Steps Electric Heat	410	410	410	410	430
80 kW/208/3/60 or 108 kW/240/3/60 5 Steps Electric Heat	490	490	490	490	510
108 kW/415/3/60 4 steps Electric Heat	450	450	450	450	470
150 kW/415/3/60 5 Steps Electric Heat	470	470	470	470	490
200 kW/415/3/60 or 200 kW/480/3/60 6 Steps Electric Heat	490	490	490	490	510
250 kW/480/3/60 7 Steps Electric Heat	510	510	510	510	530
Condenser Wire Guard	32	32	32	32	40
Copper Condenser Coils (additional)	617	617	793	793	617
Copper Evaporator Coils (additional)	262	320	400	500	280
Hot water coil	281	281	281	281	318
Steam heating coil	202	202	202	202	236
Diffuser ³	44	44	44	44	53
Final filters ³	344	344	344	344	535
Final filters, racks only ³	224	224	224	224	297
Roof Curb Weights (Lbs.)					
14" Full Perimeter Roof Curb	825	825	825	825	1,020
14" Open Condenser Roof Curb	555	555	555	555	577
Compressor Data					
Quantity/Size (Nominal HP)	4x13	4x13	4x15	4x15	4x10, 2x13
Type	Scroll	Scroll	Scroll	Scroll	Scroll
Capacity Steps (Qty x %)	4x25	4x25	4x25	4x25	4x15, 2x20
Supply Fan and Drive					
Quantity	1	1	1	1	1
Type	FC	FC	FC	FC	FC
Size	25-22	25-22	25-22	25-22	28-25
Motor Size Range (min. to max. HP)	7.5-40	7.5-40	7.5-40	7.5-40	7.5-60
Air Flow Range (min. to max. cfm)	10000-22500	10000-24000	14000-27000	14000-27000	14000-32000
Static Pressure Range (min. to max. ESP)	0-4"	0-4"	0-4"	0-4"	0-4"
Optional Airfoil Supply Fan					
Quantity	1 / 1	1 / 1	1 / 1	1 / 1	1 / 1
Type	AF	AF	AF	AF	AF
Size	25	25	25	25	32
Motor Size Range (min. to max. HP)	7.5-40	7.5-40	7.5-40	7.5-40	7.5-50
Air Flow Range (min. to max. cfm)	0-27000	0-27000	0-27000	0-27000	0-32000
Static Pressure Range (min. to max. ESP)	0-6"	0-6"	0-6"	0-6"	0-6"

TABLE 3 – PHYSICAL DATA – MODELS 50-70 (cont'd)

MODEL SIZE	50	55	60	65	70
Exhaust Fan					
Quantity	2	2	2	2	2
Type	FC	FC	FC	FC	FC
Size	15-15	15-15	15-15	15-15	18-18
Motor Size Range (min. to max. HP)	5-20	5-20	5-20	5-20	10-20
Air Flow Range (min. to max. cfm)	0-20000	0-20000	0-20000	0-20000	0-20000
Static Pressure Range (min. to max. ESP)	0-2"	0-2"	0-2"	0-2"	0-2"
Optional Exhaust Fan					
Quantity Fans/Motors	2 / 1	2 / 1	2 / 1	2 / 1	2 / 1
Type	FC	FC	FC	FC	FC
Size	18-18	18-18	18-18	18-18	20-18
Motor Size Range (min. to max. HP)	5-20	5-20	5-20	5-20	5-30
Airflow Range (min. to max. cfm)	0-22500	0-24000	0-27000	0-27000	0-32000
Static pressure range (min. to max., iwg)	0-1"	0-1"	0-1"	0-1"	0-1"
Optional Return Fan					
Quantity Fans/Motors	2 / 2	2 / 2	2 / 2	2 / 2	2 / 2
Type	Plenum	Plenum	Plenum	Plenum	Plenum
Size	245	245	245	245	270
Motor Size Range (min. to max. HP)	5-30	5-30	5-30	5-30	5-30
Airflow Range (min. to max. cfm)	0-22500	0-24000	0-27000	0-27000	0-32000
Static pressure range (min. to max., iwg)	0-3"	0-3"	0-3"	0-3"	0-3"
Evaporator Coil					
Size (square feet)	48.8	48.8	48.8	48.8	56.9
Number of rows/fins per inch	3/8	4/8	4/10	5/8	4/8
Tube Diameter/Surface	1/2"/enhanced	1/2"/enhanced	1/2"/enhanced	1/2"/enhanced	1/2"/enhanced
Condenser Coil (R22, Al & Cu Fin)					
Size (square feet)	121	121	121	121	182
Number of rows/fins per inch	2/14	2/14	2/14	2/14	2/10
Tube diameter	3/8"	3/8"	3/8"	3/8"	3/8"
Condenser Coil (R407C, Al & Cu Fin)					
Size (square feet)	121	121	121	121	182
Number of rows/fins per inch	3/16	3/16	3/16	3/16	2/14
Tube diameter	3/8"	3/8"	3/8"	3/8"	3/8"
Condenser Fans					
Quantity	4	4	4	4	6
Type	Prop.	Prop.	Prop.	Prop.	Prop.
Diameter (inches)	36	36	36	36	36
Power (hp each)	2	2	2	2	2
Filters - 2" throwaway (pre-filter position)					
Quantity	8 / 12	8 / 12	8 / 12	8 / 12	10 / 15
Size (length x width) (in.)	25X16 / 25x20	25X16 / 25x20	25X16 / 25x20	25X16 / 25x20	25X16 / 25x20
Total Filter Face Area (square feet)	61.6	61.6	61.6	61.6	77.1
Filters - 2" cleanable (pre-filter position)					
Quantity	8 / 12	8 / 12	8 / 12	8 / 12	10 / 15
Size (length x width) (in.)	25X16 / 25x20	25X16 / 25x20	25X16 / 25x20	25X16 / 25x20	25X16 / 25x20
Total Filter Face Area (square feet)	63.9	63.9	63.9	63.9	77.1
Filters - 2" pleated, 30% efficient (pre-filter position)					
Quantity	8 / 12	8 / 12	8 / 12	8 / 12	10 / 15
Size (length x width) (in.)	25X16 / 25x20	25X16 / 25x20	25X16 / 25x20	25X16 / 25x20	25X16 / 25x20
Total Filter Face Area (square feet)	63.9	63.9	63.9	63.9	77.1

Physical Data (continued)

TABLE 3 – PHYSICAL DATA – MODELS 50-70 (cont'd)

MODEL SIZE	50	55	60	65	70
Filters -12" rigid 65%, 2" 30% prefilter (pre-filter position)					
Quantity	1 / 4 / 9	1 / 4 / 9	1 / 4 / 9	1 / 4 / 9	2 / 8 / 9
Size (length x width) (in.)	16x20/25x16/25x20	16x20/25x16/25x20	16x20/25x16/25x20	16x20/25x16/25x20	16x20/25x16/25x20
Total Filter Face Area (square feet)	43.0	43.0	43.0	43.0	55.8
Filters -12" rigid 95%, 2" 30% prefilter (pre-filter position)					
Quantity	1 / 4 / 9	1 / 4 / 9	1 / 4 / 9	1 / 4 / 9	2 / 8 / 9
Size (length x width) (in.)	16x20/25x16/25x20	16x20/25x16/25x20	16x20/25x16/25x20	16x20/25x16/25x20	16x20/25x16/25x20
Total Filter Face Area (square feet)	44.6	44.6	44.6	44.6	55.8
Filters - 2" carbon (pre-filter position)					
Quantity	1 / 4 / 9	1 / 4 / 9	1 / 4 / 9	1 / 4 / 9	10 / 15
16x20/25x16/25x20	16x20/25x16/25x20	16x20/25x16/25x20	16x20/25x16/25x20	25X16 / 25x20	
Total Filter Face Area (square feet)	44.6	44.6	44.6	44.6	77.1
Filters - 12" rigid 95% in Post-filter Position					
Quantity	1 / 3 / 9	1 / 3 / 9	1 / 3 / 9	1 / 3 / 9	2 / 7 / 9
Size (length x width) (in.)	16x20/25x16/25x20	16x20/25x16/25x20	16x20/25x16/25x20	16x20/25x16/25x20	16x20/25x16/25x20
Total Filter Face Area (square feet)	41.8	41.8	41.8	41.8	55.1
Gas Furnace					
Staged Furnace Sizes (input/output/stages)	375 mbh / 300 mbh / 2 stages				
	750 mbh / 600 mbh / 4 stages				
Gas Pressure Range (min. to max. iwg)	3-14" w.c.	3-14" w.c.	3-14" w.c.	3-14" w.c.	3-14" w.c.
Airflow Range (min. to max. cfm)	6,950-27,000	6,950-27,000	11,150-27,000	11,150-27,000	6,950-36,000
Modulating Furnace Sizes (input/output/turndown)	375 mbh / 300 mbh / 8:1 turndown				
	750 mbh / 600 mbh / 16:1 turndown				
Gas Pressure Range (min. to max. iwg)	3.5-14" w.c. ²	3.5-14" w.c. ²	3.5-14" w.c. ²	3.5-14" w.c. ²	3.5-14" w.c. ²
Airflow Range (min. to max. cfm)	8,250-27,000	8,250-27,000	11,150-27,000	11,150-27,000	8,250-36,000
Electric Heaters					
Size Range (min. to max. kW)	40-150	40-150	40-150	40-150	80-200
Heating steps ¹	1-7	1-7	1-7	1-7	1-7
Minimum OA Temp. for Mech. Cig.	45	45	45	45	45
Low Ambient Option Min. OA Temp	0	0	0	0	0

NOTES

- Electric heat steps and airflow range depends on voltage and size. Consult the air pressure drop tables for specific number of steps for a given voltage.
- 3.5" is minimum gas pressure for full firing rate. 3.0" is acceptable at reduced firing rate.
- Weights are for components only and need to be added to the extended cabinet weights. The diffuser is required in the extended cabinet for any unit with hot water or final filter option.

TABLE 4 – PHYSICAL DATA – MODELS 75-95

MODEL SIZE	75	80	85	90	95	105
GENERAL DATA						
Standard cabinet length without hoods (inches)	454	454	454	488	488	488
Extended cabinet length without hoods (inches)	517	517	517	557	557	557
Width (Inches)	92	92	92	92	92	92
Height (Inches)	82	82	82	92	92	92
Weights (Lbs.) (base unit, no option)						
Base cabinet, cooling only with economizer	12,100	12,466	12,565	12,671	12,771	12,891
Extended cabinet, cooling only with economizer	13,310	13,676	13,775	13,967	14,067	14,187
Option Weights (Lbs.)						
Power Exhaust (Blower, mtr, mtr base, fan skid, mod damper & hood)	1045	1045	1045	1074	1074	1074
Power Exhaust (Blower, mtr, mtr base, fan skid, VFD, baro damper & hood)	1044	1044	1044	1068	1068	1068
100% AMS (Measurement Station & Mounting)	125	125	125	140	140	140
25/75% AMS (Measurement Station & Mounting)	146	146	146	162	162	162
Min. AMS (Measurement Station & Mounting)	45	45	45	50	50	50
Barometric only	45	45	45	55	55	55
375 MBH Gas Heat	162	162	162	162	162	162
750 MBH Gas Heat	324	324	324	324	324	324
1050 MBH Gas Heat	486	486	486	486	486	486
40 kW/415/3/60 or 40 kW/480/3/60 2 Steps Electric Heat	430	430	430	470	470	470
80 kW/208/3/60 or 108 kW/240/3/60 5 Steps Electric Heat	510	510	510	550	550	550
108 kW/415/3/60 4 steps Electric Heat	470	470	470	510	510	510
150 kW/415/3/60 5 Steps Electric Heat	490	490	490	530	530	530
200 kW/415/3/60 or 200 kW/480/3/60 6 Steps Electric Heat	510	510	510	550	550	550
250 kW/480/3/60 7 Steps Electric Heat	530	530	530	570	570	570
Condenser Wire Guard	40	40	40	45	45	45
Copper Condenser Coils (additional)	617	1,058	1,058	1,190	1,190	1,190
Copper Evaporator Coils (additional)	460	280	460	460	580	580
Hot water coil	318	318	318	318	318	318
Steam heating coil	236	236	236	236	236	236
Diffuser ³	53	53	53	53	53	53
Final filters ³	535	535	535	565	565	565
Final filters, racks only ³	297	297	297	327	327	327
Roof Curb Weights (Lbs.)						
14" Full Perimeter Roof Curb	1,020	1,020	1,020	1,040	1,040	1,040
14" Open Condenser Roof Curb	577	577	577	615	615	615
Compressor Data						
Quantity/Size (Nominal HP)	4x10, 2x13	6x13	6x13	2x13, 4x15	2x13, 4x15	6x15
Type	Scroll	Scroll	Scroll	Scroll	Scroll	Scroll
Capacity Steps (Qty x %)	4x15, 2x20	6x16	6x16	4x18, 2x15	4x18, 2x15	6x16
Supply Fan and Drive						
Quantity	1	1	1	1	1	1
Type	FC	FC	FC	FC	FC	FC
Size	28-25	28-25	28-25	28-28	28-28	28-28
Motor Size Range (min. to max. HP)	7.5-60	7.5-60	7.5-60	7.5-60	7.5-60	7.5-60
Air Flow Range (min. to max. cfm)	14000-32000	14000-32000	14000-32000	18000-36000	18000-36000	18000-36000
Static Pressure Range (min. to max. ESP)	0-4"	0-4"	0-4"	0-4"	0-4"	0-4"
Optional Airfoil Supply Fan						
Quantity	1/1	1/1	1/1	1/1	1/1	1/1
Type	AF	AF	AF	AF	AF	AF
Size	32	32	32	32	32	32
Motor Size Range (min. to max. HP)	7.5-50	7.5-50	7.5-50	7.5-60	7.5-60	7.5-60
Air Flow Range (min. to max. cfm)	0-32000	0-32000	0-32000	0-36000	0-36000	0-36000
Static Pressure Range (min. to max. ESP)	0-6"	0-6"	0-6"	0-6"	0-6"	0-6"

Physical Data (continued)

TABLE 4 – PHYSICAL DATA – MODELS 75-95 (cont'd)

MODEL SIZE	75	80	85	90	95	105
Exhaust Fan						
Quantity	2	2	2	2	2	2
Type	FC	FC	FC	FC	FC	FC
Size	18-18	18-18	18-18	18-18	18-18	18-18
Motor Size Range (min. to max. HP)	10-20	10-20	10-20	10-20	10-20	10-20
Air Flow Range (min. to max. cfm)	0-20000	0-20000	0-20000	0-20000	0-20000	0-20000
Static Pressure Range (min. to max. ESP)	0-2"	0-2"	0-2"	0-2"	0-2"	0-2"
Optional Exhaust Fan						
Quantity Fans/Motors	2 / 1	2 / 1	2 / 1	2 / 1	2 / 1	2 / 1
Type	FC	FC	FC	FC	FC	FC
Size	20-18	20-18	20-18	20-18	20-18	20-18
Motor Size Range (min. to max. HP)	5-30	5-30	5-30	5-30	5-30	5-30
Airflow Range (min. to max. cfm)	0-32000	0-32000	0-32000	0-36000	0-36000	0-36000
Static pressure range (min. to max., iwg)	0-1"	0-1"	0-1"	0-1"	0-1"	0-1"
Optional Return Fan						
Quantity Fans/Motors	2 / 2	2 / 2	2 / 2	2 / 2	2 / 2	2 / 2
Type	Plenum	Plenum	Plenum	Plenum	Plenum	Plenum
Size	270	270	270	270	270	270
Motor Size Range (min. to max. HP)	5-30	5-30	5-30	5-40	5-40	5-40
Airflow Range (min. to max. cfm)	0-32000	0-32000	0-32000	0-36000	0-36000	0-36000
Static pressure range (min. to max., iwg)	0-3"	0-3"	0-3"	0-3"	0-3"	0-3"
Evaporator Coil						
Size (square feet)	56.9	56.9	56.9	56.9	56.9	56.9
Number of rows/fins per inch	5/8	4/10	5/8	4/10	Scroll	5/10
Tube Diameter/Surface	1/2"/enhanced	1/2"/enhanced	1/2"/enhanced	1/2"/enhanced	1/2"/enhanced	1/2"/enhanced
Condenser Coil (R22, Al & Cu Fin)						
Size (square feet)	182	182	182	182	182	182
Number of rows/fins per inch	2/10	2/14	2/14	2/14	2/14	2/16
Tube diameter	3/8"	3/8"	3/8"	3/8"	3/8"	3/8"
Condenser Coil (R407C, Al & Cu Fin)						
Size (square feet)	182	182	182	182	182	182
Number of rows/fins per inch	2/14	3/16	3/16	3/16	3/16	3/16
Tube diameter	3/8"	3/8"	3/8"	3/8"	3/8"	3/8"
Condenser Fans						
Quantity	6	6	6	6	6	6
Type	Prop.	Prop.	Prop.	Prop.	Prop.	Prop.
Diameter (inches)	36	36	36	36	36	36
Power (hp each)	2	2	2	2	2	2
Filters - 2" throwaway (pre-filter position)						
Quantity	10 / 15	10 / 15	10 / 15	12 / 18	12 / 18	12 / 18
Size (length x width) (in.)	25X16 / 25x20	25X16 / 25x20	25X16 / 25x20	25X16 / 25x20	25X16 / 25x20	25X16 / 25x20
Total Filter Face Area (square feet)	77.1	77.1	77.1	92.5	92.5	92.5
Filters - 2" cleanable (pre-filter position)						
Quantity	10 / 15	10 / 15	10 / 15	12 / 18	12 / 18	12 / 18
Size (length x width) (in.)	25X16 / 25x20	25X16 / 25x20	25X16 / 25x20	25X16 / 25x20	25X16 / 25x20	25X16 / 25x20
Total Filter Face Area (square feet)	77.1	77.1	77.1	92.5	92.5	92.5
Filters - 2" pleated, 30% efficient (pre-filter position)						
Quantity	10 / 15	10 / 15	10 / 15	12 / 18	12 / 18	12 / 18
Size (length x width) (in.)	25X16 / 25x20	25X16 / 25x20	25X16 / 25x20	25X16 / 25x20	25X16 / 25x20	25X16 / 25x20
Total Filter Face Area (square feet)	77.1	77.1	77.1	92.5	92.5	92.5

TABLE 4 – PHYSICAL DATA – MODELS 75-95 (cont'd)

MODEL SIZE	75	80	85	90	95	105
Filters -12" rigid 65%, 2" 30% prefilter (pre-filter position)						
Quantity	2 / 8 / 9	2 / 8 / 9	2 / 8 / 9	8 / 12	8 / 12	8 / 12
Size (length x width) (in.)	16x20/25x16/25x20	16x20/25x16/25x20	16x20/25x16/25x20	25x16/25x20	25x16/25x20	25x16/25x20
Total Filter Face Area (square feet)	55.8	55.8	55.8	61.6	61.6	61.6
Filters -12" rigid 95%, 2" 30% prefilter (pre-filter position)						
Quantity	2 / 8 / 9	2 / 8 / 9	2 / 8 / 9	8 / 12	8 / 12	8 / 12
Size (length x width) (in.)	16x20/25x16/25x20	16x20/25x16/25x20	16x20/25x16/25x20	25x16/25x20	25x16/25x20	25x16/25x20
Total Filter Face Area (square feet)	55.8	55.8	55.8	61.6	61.6	61.6
Filters - 2" carbon (pre-filter position)						
Quantity	10 / 15	10 / 15	10 / 15	12 / 18	12 / 18	12 / 18
Size (length x width) (in.)	25X16 / 25x20	25X16 / 25x20	25X16 / 25x20	25X16 / 25x20	25X16 / 25x20	25X16 / 25x20
Total Filter Face Area (square feet)	77.1	77.1	77.1	92.5	92.5	92.5
Filters - 12" rigid 95% in Post-filter Position						
Quantity	2 / 7 / 9	2 / 7 / 9	2 / 7 / 9	7 / 12	7 / 12	7 / 12
Size (length x width) (in.)	16x20/25x16/25x20	16x20/25x16/25x20	16x20/25x16/25x20	25x16/25x20	25x16/25x20	25x16/25x20
Total Filter Face Area (square feet)	55.1	55.1	55.1	61.1	61.1	61.1
Gas Furnace						
Staged Furnace Sizes (input/output/stages)	375 mbh / 300 mbh / 2 stages					
	750 mbh / 600 mbh / 4 stages					
	1125 mbh / 600 mbh / 6 stages					
Gas Pressure Range (min. to max. iwg)	3-14" w.c.	3-14" w.c.	3-14" w.c.	3-14" w.c.	3-14" w.c.	3-14" w.c.
Airflow Range (min. to max. cfm)	6,950-36,000	11,150-36,000	11,150-36,000	15,150-36,000	15,150-36,000	15,150-36,000
Modulating Furnace Sizes (input/output/turndown)	375 mbh / 300 mbh / 8:1 turndown					
	750 mbh / 600 mbh / 16:1 turndown					
	1125 mbh / 900 mbh / 24:1 turndown					
Gas Pressure Range (min. to max. iwg)	3.5-14" w.c. ²	3.5-14" w.c. ²	3.5-14" w.c. ²	3.5-14" w.c. ²	3.5-14" w.c. ²	3.5-14" w.c. ²
Airflow Range (min. to max. cfm)	8,250-3600	11,150-36,000	11,150-36,000	15,150-36,000	15,150-36,000	15,150-36,000
Electric Heaters						
Size Range (min. to max. kW)	80-200	80-200	80-200	80-250	80-250	80-251
Heating steps ¹	1-7	1-7	1-7	1-7	1-7	1-8
Minimum OA Temp. for Mech. Cig.	45	45	45	45	45	45
Low Ambient Option Min. OA Temp	0	0	0	0	0	0

NOTES

1. Electric heat steps and airflow range depends on voltage and size. Consult the air pressure drop tables for specific number of steps for a given voltage.
2. 3.5" is minimum gas pressure for full firing rate. 3.0" is acceptable at reduced firing rate.
3. Weights are for components only and need to be added to the extended cabinet weights. The diffuser is required in the extended cabinet for any unit with hot water or final filter option.

Physical Data (continued)

TABLE 5 – PHYSICAL DATA – MODELS 106-130

MODEL SIZE	106	110	115	130
General Data				
Length - standard cabinet without hoods (inches)	378	378	378	378
Base width without hoods (Inches)	135	135	135	135
Base height (Inches)	92	92	92	92
Weights (Lbs.) (base unit, no option)				
Base cabinet, cooling only with economizer	14,254	14,449	14,569	15,444
Option Weights (Lbs.)				
Exhaust Fan, Modulating Damper Control	1825	1825	1825	1825
Exhaust Fan, Modulating VFD Control	2115	2115	2115	2115
Return Fan, (includes VFD)	2449	2449	2449	2449
Barometric only	538	538	538	538
Modulating Economizer	1541	1541	1541	1541
375 MBH Gas Heat	192	192	192	192
750 MBH Gas Heat	334	334	334	334
1125 MBH Gas Heat	474	474	474	474
Electric Heaters	263	263	263	263
Condenser Wire Guard	65	65	65	65
Perforated Panels	357	357	357	357
Copper Condenser Coils (additional)	720	485	485	485
Copper Evaporator Coils (additional)	740	740	740	740
Compressor Data				
Quantity/Size (Nominal HP)	6x15	6x15	4x20 / 2x15	6x20
Type	Scroll	Scroll	Scroll	Scroll
Capacity Steps (Qty x %)	6x16	6x16	2x13, 4x18	6x16
Supply Fan and Drive				
Quantity	1 / 1	1 / 1	1 / 1	1 / 1
Type	DWDI Airfoil	DWDI Airfoil	DWDI Airfoil	DWDI Airfoil
Size	40	40	40	40
Motor Size Range (min. to max. HP)	10-75	10-75	10-75	10-75
Air Flow Range (min. to max. cfm)	24000-46000	24000-46000	24000-46000	24000-46000
Static Pressure Range (min. to max. ESP)	0-6"	0-6"	0-6"	0-6"
Exhaust Fan				
Quantity	1	1	1	1
Type		DWDI Forward-Curved		
Size	32-32	32-32	32-32	32-32
Motor Size Range (min. to max. HP)	7.5-40	7.5-40	7.5-40	7.5-40
Air Flow Range (min. to max. cfm)	0-46000	0-46000	0-46000	0-46000
Static Pressure Range (min. to max. ESP)	0-2"	0-2"	0-2"	0-2"
Return Fan				
Quantity Fans/Motors	1 / 1	1 / 1	1 / 1	1 / 1
Type	SWSI Plenum	SWSI Plenum	SWSI Plenum	SWSI Plenum
Size	445	445	445	445
Motor Size Range (min. to max. HP)	5-40	5-40	5-40	5-40
Airflow Range (min. to max. cfm)	0-46000	0-46000	0-46000	0-46000
Static pressure range (min. to max., iwg)	0-3"	0-3"	0-3"	0-3"
Evaporator Coil				
Size (square feet)	68.9	68.9	68.9	68.9
Number of rows/fins per inch	3 / 10	4 / 10	4 / 10	5 / 10
Tube Diameter/Surface	1/2"/enhanced	1/2"/enhanced	1/2"/enhanced	1/2"/enhanced

TABLE 5 – PHYSICAL DATA – MODELS 106-130

MODEL SIZE	106	110	115	130
Condenser Coil (R22, Al & Cu Fin)				
Size (square feet)	145	145	145	145
Number of rows/fins per inch	2 / 17	2 / 17	2 / 17	3 / 13
Tube diameter	3/8"	3/8"	3/8"	3/8"
Condenser Fans				
Quantity	6	6	6	6
Type	Prop.	Prop.	Prop.	Prop.
Diameter (inches)	36	36	36	36
Power (hp each)	2	2	2	2
Filters - 2" throwaway (pre-filter position)				
Quantity	24 / 8	24 / 8	24 / 8	24 / 8
Size (length x width) (in.)	25x16 / 25x20	25x16 / 25x20	25x16 / 25x20	25x16 / 25x20
Total Filter Face Area (Square feet)	94.4	94.4	94.4	94.4
Filters - 2" cleanable (pre-filter position)				
Quantity	24 / 8	24 / 8	24 / 8	24 / 8
Size (length x width) (in.)	25x16 / 25x20	25x16 / 25x20	25x16 / 25x20	25x16 / 25x20
Total Filter Face Area (Square feet)	94.4	94.4	94.4	94.4
Filters - 2" pleated, 30% efficient (pre-filter position)				
Quantity	24 / 8	24 / 8	24 / 8	24 / 8
Size (length x width) (in.)	25x16 / 25x20	25x16 / 25x20	25x16 / 25x20	25x16 / 25x20
Total Filter Face Area (Square feet)	94.4	94.4	94.4	94.4
Filters -12" rigid 65%, 2" 30% prefilter (pre-filter position)				
Quantity	10 / 15	10 / 15	10 / 15	10 / 15
Size (length x width) (in.)	20X16 / 25x20	20X16 / 25x20	20X16 / 25x20	20X16 / 25x20
Total Filter Face Area (Square feet)	74.3	74.3	74.3	74.3
Filters -12" rigid 95%, 2" 30% prefilter (pre-filter position)				
Quantity	10 / 15	10 / 15	10 / 15	10 / 15
Size (length x width) (in.)	20X16 / 25x20	20X16 / 25x20	20X16 / 25x20	20X16 / 25x20
Total Filter Face Area (Square feet)	74.3	74.3	74.3	74.3
Filters - 2" carbon (pre-filter position)				
Quantity	24 / 8	24 / 8	24 / 8	24 / 8
Size (length x width) (in.)	25x16 / 25x20	25x16 / 25x20	25x16 / 25x20	25x16 / 25x20
Total Filter Face Area (Square feet)	94.4	94.4	94.4	94.4
Gas Furnace				
Staged Furnace Sizes (input/output/stages)	125 mbh / 900 mbh / 6 stages			
Gas Pressure Range (min. to max. iwg)	3.5-14" w.c.	3.5-14" w.c.	3.5-14" w.c.	3.5-14" w.c.
Modulating Furnace Sizes (input/output/turndown)	1125 mbh / 900 mbh / 24:1 turndown			
Gas Pressure Range (min. to max. iwg)	3.5-14" w.c.	3.5-14" w.c.	3.5-14" w.c.	3.5-14" w.c.
Electric Heaters				
Size Range (min. to max. kW)	40-250	40-250	40-250	40-250
Heating steps ¹	1-6	1-6	1-6	1-6
Minimum step ¹	2	2	2	2
Minimum OA Temp. for Mech. Cig.	0	0	0	0
Low Ambient Option Min. OA Temp	0	0	0	0

NOTES

1. Electric heat steps and airflow range depends on voltage and size. Consult the air pressure drop tables for specific number of steps for a given voltage.
2. 3.5" is minimum gas pressure for full firing rate. 3.0" is acceptable at reduced firing rate.
3. Weights are for components only and need to be added to the extended cabinet weights. The diffuser is required in the extended cabinet for any unit with hot water or final filter option.

Cooling Performance Data – 50 Ton Model

TABLE 6 – COOLING PERFORMANCE DATA* – 50 TON MODEL

85° AIR ON CONDENSER COIL

CFM	ENTERING WB (°F)	CAPACITY (mbh) AT ENTERING DRY BULB (°F)															
		90		86		83		80		77		74		71		68	
		CAP	SHC	CAP	SHC	CAP	SHC	CAP	SHC	CAP	SHC	CAP	SHC	CAP	SHC	CAP	SHC
12000	75	722	382	722	347	722	312	722	277	722	242	—	—	—	—	—	—
	73	696	408	696	373	696	338	696	303	696	267	696	232	—	—	—	—
	71	670	433	670	398	670	363	670	328	670	293	670	257	—	—	—	—
	67	619	482	619	447	619	412	619	377	619	342	619	307	619	271	619	236
	62	—	—	558	506	558	470	558	435	558	400	558	365	558	330	558	295
14000	75	747	408	747	368	747	328	747	288	747	248	—	—	—	—	—	—
	73	721	438	721	398	721	357	721	317	721	277	721	237	—	—	—	—
	71	695	467	695	427	695	386	695	346	695	306	695	266	—	—	—	—
	67	645	523	645	483	645	443	645	403	645	363	645	323	645	283	645	243
	62	588	588	583	552	583	511	583	471	583	431	583	391	583	351	583	311
16000	75	768	433	768	388	768	343	768	298	768	253	—	—	—	—	—	—
	73	742	466	742	421	742	376	742	331	742	286	742	241	—	—	—	—
	71	716	498	716	453	716	408	716	363	716	319	716	274	—	—	—	—
	67	665	562	665	517	665	472	665	428	665	383	665	338	665	293	665	248
	62	616	616	598	598	604	550	604	505	604	460	604	415	604	370	604	325
18000	75	784	456	784	407	784	357	784	308	784	258	—	—	—	—	—	—
	73	758	493	758	443	758	393	758	344	758	294	758	245	—	—	—	—
	71	733	528	733	479	733	429	733	380	733	330	733	280	—	—	—	—
	67	682	599	682	550	682	500	682	451	682	401	682	351	682	302	682	252
	62	641	641	622	622	621	586	621	537	621	487	621	437	621	388	621	338
20000	75	798	479	798	425	798	371	798	317	798	262	—	—	—	—	—	—
	73	772	518	772	464	772	410	772	356	772	302	772	248	—	—	—	—
	71	747	557	747	503	747	449	747	395	747	341	747	287	—	—	—	—
	67	696	635	696	581	696	526	696	472	696	418	696	364	696	310	696	256
	62	663	663	643	643	623	623	635	567	635	513	635	459	635	404	635	350
22000	75	809	500	809	442	809	383	809	325	809	266	—	—	—	—	—	—
	73	783	543	783	484	783	426	783	367	783	309	783	250	—	—	—	—
	71	758	585	758	526	758	468	758	409	758	351	758	293	—	—	—	—
	67	708	669	708	610	708	552	708	493	708	435	708	376	708	318	708	259
	62	681	681	661	661	641	641	648	596	648	537	648	479	648	420	648	362
24000	75	819	521	819	458	819	396	819	333	819	270	—	—	—	—	—	—
	73	793	567	793	504	793	441	793	378	793	316	793	253	—	—	—	—
	71	768	612	768	549	768	486	768	423	768	361	768	298	—	—	—	—
	67	698	698	718	639	718	576	718	513	718	450	718	388	718	325	718	262
	62	698	698	677	677	657	657	658	623	658	561	658	498	658	435	658	372

* Rated performance is at sea level. Cooling capacities are gross cooling capacity.

TABLE 6 – COOLING PERFORMANCE DATA* – 50 TON MODEL (cont'd)

95° AIR ON CONDENSER COIL

CFM	ENTERING WB (°F)	CAPACITY (mbh) AT ENTERING DRY BULB (°F)															
		90		86		83		80		77		74		71		68	
		CAP	SHC	CAP	SHC	CAP	SHC	CAP	SHC	CAP	SHC	CAP	SHC	CAP	SHC	CAP	SHC
12000	75	699	374	699	339	699	304	699	269	699	233	—	—	—	—	—	—
	73	674	400	674	365	674	329	674	294	674	259	674	224	—	—	—	—
	71	650	425	650	390	650	355	650	320	650	285	650	249	—	—	—	—
	67	602	475	602	440	602	404	602	369	602	334	602	299	602	264	602	229
	62	543	543	544	499	544	464	544	429	544	394	544	358	544	323	544	288
14000	75	721	400	721	359	721	319	721	279	721	239	—	—	—	—	—	—
	73	697	429	697	389	697	349	697	309	697	268	697	228	—	—	—	—
	71	673	458	673	418	673	378	673	338	673	298	673	257	—	—	—	—
	67	625	515	625	475	625	435	625	395	625	355	625	315	625	275	625	234
	62	574	574	557	557	567	504	567	464	567	424	567	384	567	344	567	303
16000	75	740	424	740	379	740	334	740	289	740	244	—	—	—	—	—	—
	73	715	457	715	412	715	367	715	322	715	277	715	232	—	—	—	—
	71	691	489	691	444	691	399	691	354	691	310	691	265	—	—	—	—
	67	644	554	644	509	644	464	644	419	644	374	644	329	644	284	644	239
	62	601	601	583	583	586	542	586	497	586	452	586	407	586	362	586	317
18000	75	755	447	755	397	755	348	755	298	755	248	—	—	—	—	—	—
	73	730	483	730	433	730	384	730	334	730	285	730	235	—	—	—	—
	71	706	519	706	469	706	420	706	370	706	321	706	271	—	—	—	—
	67	659	590	659	541	659	491	659	441	659	392	659	342	659	293	659	243
	62	624	624	606	606	588	588	602	528	602	479	602	429	602	380	602	330
20000	75	767	469	767	415	767	361	767	307	767	253	—	—	—	—	—	—
	73	743	508	743	454	743	400	743	346	743	292	743	238	—	—	—	—
	71	719	548	719	494	719	439	719	385	719	331	719	277	—	—	—	—
	67	672	625	672	571	672	517	672	463	672	409	672	355	672	301	672	247
	62	645	645	626	626	607	607	615	558	615	504	615	450	615	396	615	342
22000	75	777	490	777	432	777	373	777	315	777	257	—	—	—	—	—	—
	73	753	533	753	474	753	416	753	357	753	299	753	240	—	—	—	—
	71	729	575	729	517	729	458	729	400	729	341	729	283	—	—	—	—
	67	662	662	683	600	683	542	683	484	683	425	683	367	683	308	683	250
	62	662	662	643	643	624	624	626	586	626	528	626	470	626	411	626	353
24000	75	786	511	786	448	786	386	786	323	786	260	—	—	—	—	—	—
	73	762	556	762	494	762	431	762	368	762	305	762	243	—	—	—	—
	71	738	602	738	539	738	476	738	413	738	351	738	288	—	—	—	—
	67	678	678	692	629	692	566	692	503	692	441	692	378	692	315	692	252
	62	678	678	658	658	638	638	618	618	635	551	635	488	635	426	635	363

* Rated performance is at sea level. Cooling capacities are gross cooling capacity.

Cooling Performance Data – 50 Ton Model (cont'd.)

TABLE 6 – COOLING PERFORMANCE DATA* – 50 TON MODEL (cont'd)

105° AIR ON CONDENSER COIL

CFM	ENTERING WB (°F)	CAPACITY (mbh) AT ENTERING DRY BULB (°F)															
		90		86		83		80		77		74		71		68	
		CAP	SHC	CAP	SHC	CAP	SHC	CAP	SHC	CAP	SHC	CAP	SHC	CAP	SHC	CAP	SHC
12000	75	671.8	364.4	671.8	329.3	671.8	294.2	671.8	259.0	671.8	223.9	—	—	—	—	—	—
	73	649.0	390.3	649.0	355.2	649.0	320.1	649.0	285.0	649.0	249.8	649.0	214.7	—	—	—	—
	71	626.4	416.0	626.4	380.9	626.4	345.7	626.4	310.6	626.4	275.5	626.4	240.3	0.0	0.0	0.0	0.0
	67	581.9	466.3	581.9	431.1	581.9	396.0	581.9	360.9	581.9	325.7	581.9	290.6	581.9	255.5	581.9	220.4
	62	529.6	529.6	527.7	491.5	527.7	456.3	527.7	421.2	527.7	386.1	527.7	350.9	527.7	315.8	527.7	280.7
14000	75	692.0	389.5	692.0	349.4	692.0	309.3	692.0	269.1	692.0	229.0	—	—	—	—	—	—
	73	669.4	419.1	669.4	379.0	669.4	338.8	669.4	298.7	669.4	258.6	669.4	218.4	0.0	0.0	0.0	0.0
	71	647.0	448.4	647.0	408.3	647.0	368.2	647.0	328.0	647.0	287.9	647.0	247.8	0.0	0.0	0.0	0.0
	67	602.7	506.2	602.7	466.1	602.7	426.0	602.7	385.8	602.7	345.7	602.7	305.6	602.7	265.4	602.7	225.3
	62	558.9	558.9	542.6	542.6	548.8	495.9	548.8	455.8	548.8	415.6	548.8	375.5	548.8	335.4	548.8	295.2
16000	75	708.2	413.4	708.2	368.5	708.2	323.5	708.2	278.6	708.2	233.6	—	—	—	—	—	—
	73	685.7	446.4	685.7	401.5	685.7	356.5	685.7	311.6	685.7	266.6	685.7	221.7	—	—	—	—
	71	663.4	479.3	663.4	434.3	663.4	389.4	663.4	344.4	663.4	299.5	663.4	254.5	—	—	—	—
	67	619.5	544.1	619.5	499.2	619.5	454.2	619.5	409.3	619.5	364.3	619.5	319.4	619.5	274.4	619.5	229.5
	62	584.0	584.0	567.0	567.0	565.9	533.2	565.9	488.2	565.9	443.3	565.9	398.3	565.9	353.4	565.9	308.4
18000	75	721.4	436.3	721.4	386.7	721.4	337.1	721.4	287.5	721.4	237.9	—	—	—	—	—	—
	73	699.0	472.6	699.0	423.0	699.0	373.4	699.0	323.8	699.0	274.2	699.0	224.6	—	—	—	—
	71	676.8	508.7	676.8	459.1	676.8	409.5	676.8	359.9	676.8	310.3	676.8	260.7	—	—	—	—
	67	633.2	580.2	633.2	530.6	633.2	481.0	633.2	431.4	633.2	381.8	633.2	332.2	633.2	282.6	633.2	233.0
	62	605.6	605.6	588.0	588.0	570.4	570.4	579.9	519.0	579.9	469.4	579.9	419.8	579.9	370.2	579.9	320.6
20000	75	732.3	458.2	732.3	404.1	732.3	350.0	732.3	295.9	732.3	241.8	—	—	—	—	—	—
	73	710.0	497.7	710.0	443.6	710.0	389.5	710.0	335.4	710.0	281.2	710.0	227.1	—	—	—	—
	71	687.9	536.9	687.9	482.8	687.9	428.7	687.9	374.6	687.9	320.5	687.9	266.4	—	—	—	—
	67	624.4	624.4	644.4	560.8	644.4	506.7	644.4	452.6	644.4	398.5	644.4	344.4	644.4	290.3	644.4	236.2
	62	624.4	624.4	606.3	606.3	588.2	588.2	591.5	548.3	591.5	494.2	591.5	440.1	591.5	386.0	591.5	331.9
22000	75	741.4	479.4	741.4	421.0	741.4	362.5	741.4	304.0	741.4	245.5	—	—	—	—	—	—
	73	719.2	521.9	719.2	463.4	719.2	404.9	719.2	346.5	719.2	288.0	719.2	229.5	—	—	—	—
	71	697.1	564.2	697.1	505.7	697.1	447.2	697.1	388.8	697.1	330.3	697.1	271.8	—	—	—	—
	67	640.8	640.8	653.9	589.8	653.9	531.3	653.9	472.9	653.9	414.4	653.9	355.9	653.9	297.4	653.9	238.9
	62	640.8	640.8	622.2	622.2	603.6	603.6	585.0	585.0	601.2	517.9	601.2	459.4	601.2	400.9	601.2	342.5
24000	75	749.2	500.0	749.2	437.3	749.2	374.5	749.2	311.8	749.2	249.0	—	—	—	—	—	—
	73	726.9	545.4	726.9	482.7	726.9	419.9	726.9	357.1	726.9	294.4	726.9	231.6	—	—	—	—
	71	705.0	590.7	705.0	527.9	705.0	465.2	705.0	402.4	705.0	339.7	705.0	276.9	—	—	—	—
	67	655.1	655.1	661.8	617.9	661.8	555.2	661.8	492.4	661.8	429.7	661.8	366.9	661.8	304.2	661.8	241.4
	62	655.1	655.1	636.1	636.1	617.1	617.1	598.1	598.1	609.4	540.7	609.4	478.0	609.4	415.2	609.4	352.5

* Rated performance is at sea level. Cooling capacities are gross cooling capacity.

TABLE 6 – COOLING PERFORMANCE DATA* – 50 TON MODEL (cont'd)

115° AIR ON CONDENSER COIL

CFM	ENTERING WB (°F)	CAPACITY (mbh) AT ENTERING DRY BULB (°F)															
		90		86		83		80		77		74		71		68	
		CAP	SHC	CAP	SHC	CAP	SHC	CAP	SHC	CAP	SHC	CAP	SHC	CAP	SHC	CAP	SHC
12000	75	672	364	672	329	672	294	672	259	672	224	—	—	—	—	—	—
	73	649	390	649	355	649	320	649	285	649	250	649	215	—	—	—	—
	71	626	416	626	381	626	346	626	311	626	275	626	240	—	—	—	—
	67	582	466	582	431	582	396	582	361	582	326	582	291	582	255	582	220
	62	530	530	528	491	528	456	528	421	528	386	528	351	528	316	528	281
14000	75	692	390	692	349	692	309	692	269	692	229	—	—	—	—	—	—
	73	669	419	669	379	669	339	669	299	669	259	669	218	—	—	—	—
	71	647	448	647	408	647	368	647	328	647	288	647	248	—	—	—	—
	67	603	506	603	466	603	426	603	386	603	346	603	306	603	265	603	225
	62	559	559	543	543	549	496	549	456	549	416	549	375	549	335	549	295
16000	75	708	413	708	368	708	324	708	279	708	234	—	—	—	—	—	—
	73	686	446	686	401	686	357	686	312	686	267	686	222	—	—	—	—
	71	663	479	663	434	663	389	663	344	663	299	663	255	—	—	—	—
	67	619	544	619	499	619	454	619	409	619	364	619	319	619	274	619	229
	62	584	584	567	567	566	533	566	488	566	443	566	398	566	353	566	308
18000	75	721	436	721	387	721	337	721	287	721	238	—	—	—	—	—	—
	73	699	473	699	423	699	373	699	324	699	274	699	225	—	—	—	—
	71	677	509	677	459	677	409	677	360	677	310	677	261	—	—	—	—
	67	633	580	633	531	633	481	633	431	633	382	633	332	633	283	633	233
	62	606	606	588	588	570	570	580	519	580	469	580	420	580	370	580	321
20000	75	732	458	732	404	732	350	732	296	732	242	—	—	—	—	—	—
	73	710	498	710	444	710	389	710	335	710	281	710	227	—	—	—	—
	71	688	537	688	483	688	429	688	375	688	321	688	266	—	—	—	—
	67	624	624	644	561	644	507	644	453	644	398	644	344	644	290	644	236
	62	624	624	606	606	588	588	592	548	592	494	592	440	592	386	592	332
22000	75	741	479	741	421	741	362	741	304	741	246	—	—	—	—	—	—
	73	719	522	719	463	719	405	719	346	719	288	719	229	—	—	—	—
	71	697	564	697	506	697	447	697	389	697	330	697	272	—	—	—	—
	67	641	641	654	590	654	531	654	473	654	414	654	356	654	297	654	239
	62	641	641	622	622	604	604	585	585	601	518	601	459	601	401	601	342
24000	75	749	500	749	437	749	375	749	312	749	249	—	—	—	—	—	—
	73	727	545	727	483	727	420	727	357	727	294	727	232	—	—	—	—
	71	705	591	705	528	705	465	705	402	705	340	705	277	—	—	—	—
	67	655	655	662	618	662	555	662	492	662	430	662	367	662	304	662	241
	62	655	655	636	636	617	617	598	598	609	541	609	478	609	415	609	352

* Rated performance is at sea level. Cooling capacities are gross cooling capacity.

Cooling Performance Data – 55 Ton Model

TABLE 7 – COOLING PERFORMANCE DATA* – 55 TON MODEL

85° AIR ON CONDENSER COIL

CFM	ENTERING WB (°F)	CAPACITY (mbh) AT ENTERING DRY BULB (°F)															
		90		86		83		80		77		74		71		68	
		CAP	SHC	CAP	SHC	CAP	SHC	CAP	SHC	CAP	SHC	CAP	SHC	CAP	SHC	CAP	SHC
12000	75	740	393	740	357	740	321	740	285	740	249	—	—	—	—	—	—
	73	714	420	714	384	714	348	714	312	714	276	714	240	—	—	—	—
	71	688	446	688	410	688	374	688	338	688	302	688	266	—	—	—	—
	67	638	497	638	461	638	425	638	389	638	353	638	317	638	281	638	245
	62	571	571	576	521	576	485	576	449	576	413	576	377	576	341	576	305
14000	75	766	420	766	379	766	338	766	296	766	255	—	—	—	—	—	—
	73	740	451	740	409	740	368	740	327	740	285	740	244	—	—	—	—
	71	714	481	714	439	714	398	714	357	714	316	714	274	—	—	—	—
	67	664	540	664	498	664	457	664	416	664	374	664	333	664	292	664	251
	62	606	606	602	569	602	528	602	487	602	445	602	404	602	363	602	322
16000	75	786	446	786	399	786	353	786	307	786	260	—	—	—	—	—	—
	73	760	480	760	433	760	387	760	341	760	294	760	248	—	—	—	—
	71	735	513	735	467	735	421	735	374	735	328	735	282	—	—	—	—
	67	684	580	684	534	684	487	684	441	684	395	684	348	684	302	684	256
	62	636	636	617	617	623	568	623	522	623	475	623	429	623	383	623	336
18000	75	803	470	803	419	803	367	803	316	803	265	—	—	—	—	—	—
	73	777	507	777	456	777	405	777	354	777	303	777	252	—	—	—	—
	71	752	545	752	493	752	442	752	391	752	340	752	289	—	—	—	—
	67	701	618	701	567	701	516	701	465	701	414	701	362	701	311	701	260
	62	662	662	643	643	640	606	640	555	640	503	640	452	640	401	640	350
20000	75	816	493	816	437	816	381	816	325	816	270	—	—	—	—	—	—
	73	791	534	791	478	791	422	791	366	791	310	791	254	—	—	—	—
	71	765	575	765	519	765	463	765	407	765	351	765	295	—	—	—	—
	67	716	655	716	599	716	543	716	487	716	432	716	376	716	320	716	264
	62	685	685	665	665	644	644	655	586	655	530	655	474	655	418	655	362
22000	75	828	516	828	455	828	395	828	334	828	274	—	—	—	—	—	—
	73	802	560	802	499	802	439	802	378	802	318	802	257	—	—	—	—
	71	777	604	777	543	777	483	777	422	777	362	777	301	—	—	—	—
	67	727	691	727	630	727	570	727	509	727	449	727	388	727	328	727	267
	62	705	705	684	684	663	663	667	616	667	555	667	495	667	434	667	374
24000	75	837	537	837	472	837	407	837	342	837	277	—	—	—	—	—	—
	73	812	585	812	520	812	455	812	390	812	325	812	260	—	—	—	—
	71	787	632	787	567	787	502	787	437	787	372	787	307	—	—	—	—
	67	722	722	737	660	737	595	737	530	737	465	737	400	737	335	737	270
	62	722	722	701	701	679	679	658	658	677	580	677	515	677	450	677	385

* Rated performance is at sea level. Cooling capacities are gross cooling capacity.

TABLE 7 – COOLING PERFORMANCE DATA* – 55 TON MODEL (cont'd)

95° AIR ON CONDENSER COIL

CFM	ENTERING WB (°F)	CAPACITY (mbh) AT ENTERING DRY BULB (°F)															
		90		86		83		80		77		74		71		68	
		CAP	SHC	CAP	SHC	CAP	SHC	CAP	SHC	CAP	SHC	CAP	SHC	CAP	SHC	CAP	SHC
12000	75	715	384	715	348	715	312	715	276	715	240	—	—	—	—	—	—
	73	691	411	691	375	691	339	691	303	691	267	691	231	—	—	—	—
	71	666	437	666	401	666	365	666	329	666	293	666	257	—	—	—	—
	67	619	489	619	453	619	416	619	380	619	344	619	308	619	272	619	236
	62	559	559	560	514	560	478	560	442	560	406	560	370	560	334	560	298
14000	75	738	411	738	369	738	328	738	287	738	246	—	—	—	—	—	—
	73	714	441	714	400	714	359	714	317	714	276	714	235	—	—	—	—
	71	690	471	690	430	690	389	690	347	690	306	690	265	—	—	—	—
	67	642	531	642	489	642	448	642	407	642	366	642	324	642	283	642	242
	62	592	592	574	574	584	520	584	479	584	437	584	396	584	355	584	314
16000	75	757	436	757	389	757	343	757	297	757	250	—	—	—	—	—	—
	73	732	470	732	423	732	377	732	331	732	285	732	238	—	—	—	—
	71	708	504	708	457	708	411	708	365	708	318	708	272	—	—	—	—
	67	661	570	661	524	661	478	661	432	661	385	661	339	661	293	661	246
	62	620	620	602	602	604	559	604	513	604	467	604	420	604	374	604	328
18000	75	771	460	771	409	771	357	771	306	771	255	—	—	—	—	—	—
	73	747	497	747	446	747	395	747	344	747	293	747	241	—	—	—	—
	71	724	535	724	483	724	432	724	381	724	330	724	279	—	—	—	—
	67	677	609	677	557	677	506	677	455	677	404	677	353	677	302	677	250
	62	644	644	626	626	607	607	619	545	619	494	619	443	619	392	619	341
20000	75	784	483	784	427	784	371	784	315	784	259	—	—	—	—	—	—
	73	760	524	760	468	760	412	760	356	760	300	760	244	—	—	—	—
	71	736	564	736	508	736	453	736	397	736	341	736	285	—	—	—	—
	67	689	645	689	589	689	533	689	477	689	421	689	366	689	310	689	254
	62	666	666	646	646	627	627	632	576	632	520	632	464	632	409	632	353
22000	75	794	505	794	445	794	384	794	324	794	263	—	—	—	—	—	—
	73	770	549	770	489	770	428	770	368	770	307	770	247	—	—	—	—
	71	746	593	746	533	746	472	746	412	746	351	746	291	—	—	—	—
	67	684	684	700	620	700	559	700	499	700	438	700	378	700	317	700	257
	62	684	684	664	664	644	644	643	606	643	545	643	485	643	424	643	364
24000	75	803	527	803	462	803	397	803	332	803	267	—	—	—	—	—	—
	73	779	574	779	509	779	444	779	379	779	314	779	249	—	—	—	—
	71	755	621	755	556	755	491	755	426	755	361	755	296	—	—	—	—
	67	700	700	709	649	709	584	709	519	709	454	709	389	709	324	709	259
	62	700	700	680	680	659	659	639	639	652	570	652	505	652	440	652	375

* Rated performance is at sea level. Cooling capacities are gross cooling capacity.

Cooling Performance Data – 55 Ton Model (cont'd.)

TABLE 7 – COOLING PERFORMANCE DATA* – 55 TON MODEL (cont'd)

105° AIR ON CONDENSER COIL

CFM	ENTERING WB (°F)	CAPACITY (mbh) AT ENTERING DRY BULB (°F)															
		90		86		83		80		77		74		71		68	
		CAP	SHC	CAP	SHC	CAP	SHC	CAP	SHC	CAP	SHC	CAP	SHC	CAP	SHC	CAP	SHC
12000	75	687	374	687	338	687	302	687	266	687	230	—	—	—	—	—	—
	73	664	401	664	365	664	329	664	293	664	257	664	221	—	—	—	—
	71	641	427	641	391	641	355	641	319	641	283	641	247	—	—	—	—
	67	597	479	597	443	597	407	597	371	597	335	597	299	597	263	597	227
	62	544	544	543	506	543	470	543	434	543	398	543	362	543	326	543	290
14000	75	707	400	707	359	707	317	707	276	707	235	—	—	—	—	—	—
	73	685	430	685	389	685	348	685	307	685	265	685	224	—	—	—	—
	71	662	461	662	420	662	378	662	337	662	296	662	255	—	—	—	—
	67	618	521	618	479	618	438	618	397	618	356	618	314	618	273	618	232
	62	575	575	559	559	564	511	564	470	564	428	564	387	564	346	564	304
16000	75	723	425	723	378	723	332	723	286	723	239	—	—	—	—	—	—
	73	701	459	701	413	701	366	701	320	701	274	701	227	—	—	—	—
	71	679	493	679	447	679	400	679	354	679	308	679	261	—	—	—	—
	67	635	560	635	514	635	467	635	421	635	375	635	329	635	282	635	236
	62	602	602	584	584	582	549	582	503	582	457	582	411	582	364	582	318
18000	75	737	448	737	397	737	346	737	295	737	244	—	—	—	—	—	—
	73	714	486	714	435	714	384	714	333	714	281	714	230	—	—	—	—
	71	692	523	692	472	692	421	692	370	692	319	692	268	—	—	—	—
	67	649	598	649	547	649	495	649	444	649	393	649	342	649	291	649	240
	62	624	624	606	606	588	588	596	535	596	484	596	433	596	382	596	330
20000	75	747	471	747	415	747	360	747	304	747	248	—	—	—	—	—	—
	73	725	512	725	456	725	400	725	345	725	289	725	233	—	—	—	—
	71	703	553	703	497	703	441	703	385	703	329	703	273	—	—	—	—
	67	644	644	660	578	660	522	660	466	660	410	660	354	660	298	660	243
	62	644	644	625	625	606	606	607	566	607	510	607	454	607	398	607	342
22000	75	757	494	757	433	757	373	757	312	757	252	—	—	—	—	—	—
	73	734	538	734	477	734	417	734	356	734	296	734	235	—	—	—	—
	71	712	582	712	521	712	461	712	400	712	339	712	279	—	—	—	—
	67	661	661	669	608	669	548	669	487	669	427	669	366	669	306	669	245
	62	661	661	642	642	623	623	603	603	617	535	617	474	617	414	617	353
24000	75	765	515	765	450	765	385	765	320	765	255	—	—	—	—	—	—
	73	742	562	742	497	742	432	742	367	742	302	742	237	—	—	—	—
	71	720	609	720	544	720	479	720	414	720	349	720	284	—	—	—	—
	67	676	676	677	638	677	573	677	508	677	443	677	378	677	313	677	248
	62	676	676	656	656	637	637	617	617	625	558	625	493	625	428	625	363

* Rated performance is at sea level. Cooling capacities are gross cooling capacity.

TABLE 7 – COOLING PERFORMANCE DATA* – 55 TON MODEL (cont'd)

115° AIR ON CONDENSER COIL

CFM	ENTERING WB (°F)	CAPACITY (mbh) AT ENTERING DRY BULB (°F)															
		90		86		83		80		77		74		71		68	
		CAP	SHC	CAP	SHC	CAP	SHC	CAP	SHC	CAP	SHC	CAP	SHC	CAP	SHC	CAP	SHC
12000	75	654	362	654	326	654	290	654	254	654	218	—	—	—	—	—	—
	73	633	389	633	353	633	317	633	281	633	245	633	209	—	—	—	—
	71	613	416	613	380	613	344	613	308	613	272	613	236	—	—	—	—
	67	572	469	572	433	572	397	572	361	572	325	572	289	572	253	572	216
	62	528	528	522	496	522	460	522	424	522	388	522	352	522	316	522	280
14000	75	672	388	672	347	672	305	672	264	672	223	—	—	—	—	—	—
	73	651	419	651	377	651	336	651	295	651	254	651	212	—	—	—	—
	71	631	449	631	408	631	367	631	325	631	284	631	243	—	—	—	—
	67	590	509	590	468	590	427	590	386	590	344	590	303	590	262	590	221
	62	556	556	540	540	541	500	541	459	541	418	541	377	541	335	541	294
16000	75	686	412	686	366	686	320	686	273	686	227	—	—	—	—	—	—
	73	665	447	665	400	665	354	665	308	665	261	665	215	—	—	—	—
	71	645	481	645	434	645	388	645	342	645	296	645	249	—	—	—	—
	67	605	548	605	502	605	456	605	409	605	363	605	317	605	271	605	224
	62	580	580	564	564	547	547	556	492	556	446	556	400	556	353	556	307
18000	75	697	436	697	385	697	334	697	282	697	231	—	—	—	—	—	—
	73	677	474	677	422	677	371	677	320	677	269	677	218	—	—	—	—
	71	657	511	657	460	657	409	657	358	657	306	657	255	—	—	—	—
	67	617	585	617	534	617	483	617	432	617	381	617	330	617	278	617	227
	62	601	601	584	584	566	566	569	524	569	472	569	421	569	370	569	319
20000	75	707	459	707	403	707	347	707	291	707	235	—	—	—	—	—	—
	73	686	500	686	444	686	388	686	332	686	276	686	220	—	—	—	—
	71	666	540	666	484	666	429	666	373	666	317	666	261	—	—	—	—
	67	619	619	627	565	627	510	627	454	627	398	627	342	627	286	627	230
	62	619	619	601	601	583	583	566	566	579	498	579	442	579	386	579	330
22000	75	715	481	715	420	715	360	715	299	715	239	—	—	—	—	—	—
	73	694	525	694	464	694	404	694	343	694	283	694	222	—	—	—	—
	71	674	569	674	508	674	448	674	387	674	327	674	266	—	—	—	—
	67	634	634	635	596	635	535	635	475	635	414	635	354	635	293	635	233
	62	634	634	616	616	598	598	580	580	587	522	587	462	587	401	587	341
24000	75	722	502	722	437	722	372	722	307	722	242	—	—	—	—	—	—
	73	701	549	701	484	701	419	701	354	701	289	701	224	—	—	—	—
	71	681	596	681	531	681	466	681	401	681	336	681	271	—	—	—	—
	67	648	648	629	629	642	560	642	495	642	430	642	365	642	300	642	235
	62	648	648	629	629	611	611	592	592	594	546	594	481	594	416	594	351

* Rated performance is at sea level. Cooling capacities are gross cooling capacity.

Cooling Performance Data – 60 Ton Model

TABLE 8 – COOLING PERFORMANCE DATA* – 60 TON MODEL

85° AIR ON CONDENSER COIL

CFM	ENTERING WB (°F)	CAPACITY (mbh) AT ENTERING DRY BULB (°F)															
		90		86		83		80		77		74		71		68	
		CAP	SHC	CAP	SHC	CAP	SHC	CAP	SHC	CAP	SHC	CAP	SHC	CAP	SHC	CAP	SHC
12000	75	852	450	852	411	852	372	852	332	852	293	—	—	—	—	—	—
	73	822	479	822	440	822	401	822	362	822	322	822	283	—	—	—	—
	71	793	508	793	469	793	429	793	390	793	351	793	312	—	—	—	—
	67	735	564	735	524	735	485	735	446	735	407	735	367	735	328	735	289
	62	665	629	665	590	665	551	665	512	665	472	665	433	665	394	665	355
14000	75	884	481	884	436	884	390	884	345	884	300	—	—	—	—	—	—
	73	854	515	854	470	854	424	854	379	854	334	854	288	—	—	—	—
	71	825	548	825	503	825	458	825	412	825	367	825	322	—	—	—	—
	67	768	613	768	568	768	523	768	478	768	432	768	387	768	342	768	297
	62	699	699	697	646	697	601	697	556	697	510	697	465	697	420	697	374
16000	75	909	511	909	459	909	408	909	357	909	306	—	—	—	—	—	—
	73	880	549	880	498	880	446	880	395	880	344	880	293	—	—	—	—
	71	851	587	851	535	851	484	851	433	851	382	851	331	—	—	—	—
	67	793	661	793	610	793	558	793	507	793	456	793	405	793	354	793	302
	62	736	736	715	714	724	648	724	597	724	546	724	494	724	443	724	392
18000	75	929	539	929	482	929	425	929	368	929	311	—	—	—	—	—	—
	73	900	582	900	525	900	467	900	410	900	353	900	296	—	—	—	—
	71	871	624	871	567	871	510	871	452	871	395	871	338	—	—	—	—
	67	814	706	814	649	814	592	814	535	814	478	814	421	814	364	814	307
	62	768	768	746	745	745	693	745	636	745	579	745	522	745	465	745	408
20000	75	946	567	946	504	946	442	946	379	946	316	—	—	—	—	—	—
	73	917	613	917	551	917	488	917	425	917	362	917	300	—	—	—	—
	71	888	659	888	597	888	534	888	471	888	408	888	346	—	—	—	—
	67	831	751	831	688	831	625	831	562	831	500	831	437	831	374	831	311
	62	796	795	773	772	750	749	763	674	763	611	763	548	763	485	763	423
22000	75	959	594	959	526	959	457	959	389	959	321	—	—	—	—	—	—
	73	930	644	930	576	930	508	930	439	930	371	930	302	—	—	—	—
	71	902	694	902	626	902	558	902	489	902	421	902	352	—	—	—	—
	67	846	794	846	725	846	657	846	588	846	520	846	452	846	383	846	315
	62	820	820	797	796	773	772	777	710	777	642	777	573	777	505	777	437
24000	75	971	621	971	547	971	473	971	399	971	325	—	—	—	—	—	—
	73	942	675	942	601	942	527	942	453	942	379	942	305	—	—	—	—
	71	913	728	913	655	913	581	913	507	913	433	913	359	—	—	—	—
	67	842	841	857	762	857	688	857	614	857	540	857	466	857	392	857	318
	62	842	841	817	816	793	792	789	745	789	671	789	597	789	524	789	450
26000	75	981	646	981	567	981	488	981	408	981	329	—	—	—	—	—	—
	73	952	704	952	625	952	546	952	466	952	387	952	307	—	—	—	—
	71	923	762	923	683	923	603	923	524	923	444	923	365	—	—	—	—
	67	860	859	867	797	867	718	867	638	867	559	867	480	867	400	867	321
	62	860	859	835	835	811	810	786	785	800	700	800	621	800	541	800	462
28000	75	989	672	989	587	989	502	989	418	989	333	—	—	—	—	—	—
	73	960	733	960	649	960	564	960	479	960	394	960	310	—	—	—	—
	71	932	795	932	710	932	625	932	540	932	456	932	371	—	—	—	—
	67	877	876	851	851	876	747	876	662	876	578	876	493	876	408	876	324
	62	877	876	851	851	826	825	801	800	808	728	808	644	808	559	808	474

* Rated performance is at sea level. Cooling capacities are gross cooling capacity.

TABLE 8 – COOLING PERFORMANCE DATA* – 60 TON MODEL (cont'd)

95° AIR ON CONDENSER COIL

CFM	ENTERING WB (°F)	CAPACITY (mbh) AT ENTERING DRY BULB (°F)															
		90		86		83		80		77		74		71		68	
		CAP	SHC	CAP	SHC	CAP	SHC	CAP	SHC	CAP	SHC	CAP	SHC	CAP	SHC	CAP	SHC
12000	75	822	438	822	399	822	360	822	321	822	282	—	—	—	—	—	—
	73	794	468	794	428	794	389	794	350	794	311	794	272	—	—	—	—
	71	766	496	766	457	766	418	766	379	766	340	766	300	—	—	—	—
	67	711	552	711	513	711	474	711	435	711	396	711	356	711	317	711	278
	62	639	638	644	580	644	540	644	501	644	462	644	423	644	384	644	344
14000	75	851	469	851	424	851	378	851	333	851	288	—	—	—	—	—	—
	73	823	503	823	457	823	412	823	367	823	322	823	276	—	—	—	—
	71	795	536	795	491	795	446	795	400	795	355	795	310	—	—	—	—
	67	741	601	741	556	741	511	741	466	741	420	741	375	741	330	741	285
	62	680	679	674	635	674	589	674	544	674	499	674	454	674	408	674	363
16000	75	874	498	874	447	874	396	874	345	874	293	—	—	—	—	—	—
	73	846	536	846	485	846	434	846	383	846	332	846	280	—	—	—	—
	71	818	574	818	523	818	472	818	421	818	369	818	318	—	—	—	—
	67	764	648	764	597	764	546	764	495	764	444	764	392	764	341	764	290
	62	715	715	694	694	698	636	698	585	698	534	698	482	698	431	698	380
18000	75	892	527	892	470	892	413	892	356	892	299	—	—	—	—	—	—
	73	864	569	864	512	864	455	864	398	864	341	864	284	—	—	—	—
	71	837	611	837	554	837	497	837	440	837	383	837	326	—	—	—	—
	67	783	694	783	637	783	580	783	523	783	466	783	409	783	352	783	295
	62	746	745	724	723	718	681	718	624	718	567	718	510	718	453	718	396
20000	75	907	554	907	492	907	429	907	366	907	303	—	—	—	—	—	—
	73	880	601	880	538	880	475	880	412	880	350	880	287	—	—	—	—
	71	852	646	852	584	852	521	852	458	852	396	852	333	—	—	—	—
	67	799	738	799	675	799	612	799	549	799	487	799	424	799	361	799	298
	62	772	771	749	749	727	726	734	661	734	598	734	535	734	473	734	410
22000	75	920	581	920	513	920	445	920	376	920	308	—	—	—	—	—	—
	73	892	631	892	563	892	495	892	426	892	358	892	290	—	—	—	—
	71	865	681	865	613	865	545	865	476	865	408	865	339	—	—	—	—
	67	795	794	812	712	812	644	812	575	812	507	812	438	812	370	812	302
	62	795	794	772	771	748	748	747	697	747	628	747	560	747	492	747	423
24000	75	930	608	930	534	930	460	930	386	930	312	—	—	—	—	—	—
	73	903	662	903	588	903	514	903	440	903	366	903	292	—	—	—	—
	71	876	715	876	641	876	567	876	494	876	420	876	346	—	—	—	—
	67	815	814	823	748	823	674	823	600	823	526	823	453	823	379	823	305
	62	815	814	791	790	767	767	744	743	758	658	758	584	758	510	758	436
26000	75	939	634	939	554	939	475	939	396	939	316	—	—	—	—	—	—
	73	912	691	912	612	912	532	912	453	912	374	912	294	—	—	—	—
	71	885	749	885	669	885	590	885	511	885	431	885	352	—	—	—	—
	67	832	831	832	784	832	704	832	625	832	546	832	466	832	387	832	307
	62	832	831	808	807	784	783	760	759	767	687	767	607	767	528	767	448
28000	75	947	659	947	574	947	490	947	405	947	320	—	—	—	—	—	—
	73	920	720	920	636	920	551	920	466	920	381	920	297	—	—	—	—
	71	893	781	893	697	893	612	893	527	893	442	893	358	—	—	—	—
	67	848	847	823	822	839	734	839	649	839	564	839	479	839	395	839	310
	62	848	847	823	822	798	798	774	773	775	714	775	630	775	545	775	460

* Rated performance is at sea level. Cooling capacities are gross cooling capacity.

Cooling Performance Data – 60 Ton Model (cont'd.)

TABLE 8 – COOLING PERFORMANCE DATA* – 60 TON MODEL (cont'd)

105° AIR ON CONDENSER COIL

CFM	ENTERING WB (°F)	CAPACITY (mbh) AT ENTERING DRY BULB (°F)															
		90		86		83		80		77		74		71		68	
		CAP	SHC	CAP	SHC	CAP	SHC	CAP	SHC	CAP	SHC	CAP	SHC	CAP	SHC	CAP	SHC
12000	75	790	426	790	387	790	348	790	309	790	269	—	—	—	—	—	—
	73	763	455	763	416	763	377	763	338	763	299	763	259	—	—	—	—
	71	736	484	736	445	736	406	736	367	736	327	736	288	—	—	—	—
	67	684	540	684	501	684	462	684	423	684	383	684	344	684	305	684	266
	62	620	619	620	568	620	529	620	490	620	450	620	411	620	372	620	333
14000	75	816	456	816	411	816	366	816	321	816	275	—	—	—	—	—	—
	73	790	490	790	445	790	400	790	354	790	309	790	264	—	—	—	—
	71	763	523	763	478	763	433	763	388	763	342	763	297	—	—	—	—
	67	711	589	711	544	711	498	711	453	711	408	711	363	711	317	711	272
	62	659	659	640	639	648	577	648	532	648	487	648	441	648	396	648	351
16000	75	837	485	837	434	837	383	837	332	837	281	—	—	—	—	—	—
	73	810	523	810	472	810	421	810	370	810	319	810	267	—	—	—	—
	71	784	561	784	510	784	459	784	407	784	356	784	305	—	—	—	—
	67	733	635	733	584	733	533	733	482	733	431	733	379	733	328	733	277
	62	692	692	672	671	670	623	670	572	670	521	670	470	670	418	670	367
18000	75	854	514	854	457	854	400	854	343	854	286	—	—	—	—	—	—
	73	827	556	827	499	827	442	827	385	827	328	827	271	—	—	—	—
	71	801	598	801	541	801	484	801	427	801	369	801	312	—	—	—	—
	67	750	680	750	623	750	566	750	509	750	452	750	395	750	338	750	281
	62	721	720	700	699	679	678	688	610	688	553	688	496	688	439	688	382
20000	75	867	541	867	479	867	416	867	353	867	290	—	—	—	—	—	—
	73	841	587	841	525	841	462	841	399	841	336	841	274	—	—	—	—
	71	815	633	815	570	815	508	815	445	815	382	815	319	—	—	—	—
	67	764	724	764	661	764	598	764	536	764	473	764	410	764	348	764	285
	62	746	745	724	723	702	701	702	647	702	584	702	522	702	459	702	396
22000	75	879	568	879	500	879	431	879	363	879	295	—	—	—	—	—	—
	73	853	618	853	550	853	481	853	413	853	345	853	276	—	—	—	—
	71	827	668	827	599	827	531	827	463	827	394	827	326	—	—	—	—
	67	767	766	776	698	776	630	776	561	776	493	776	425	776	356	776	288
	62	767	766	745	744	722	721	700	699	714	615	714	546	714	478	714	409
24000	75	889	595	889	521	889	447	889	373	889	299	—	—	—	—	—	—
	73	862	648	862	574	862	500	862	427	862	353	862	279	—	—	—	—
	71	836	702	836	628	836	554	836	480	836	406	836	332	—	—	—	—
	67	786	785	786	734	786	660	786	586	786	513	786	439	786	365	786	291
	62	786	785	763	762	740	739	717	716	724	644	724	570	724	496	724	422
26000	75	897	620	897	541	897	462	897	382	897	303	—	—	—	—	—	—
	73	871	678	871	598	871	519	871	440	871	360	871	281	—	—	—	—
	71	845	735	845	656	845	576	845	497	845	418	845	338	—	—	—	—
	67	802	801	779	778	794	690	794	611	794	531	794	452	794	373	794	293
	62	802	801	779	778	755	755	732	731	733	672	733	593	733	514	733	434
28000	75	904	646	904	561	904	476	904	392	904	307	—	—	—	—	—	—
	73	878	707	878	622	878	537	878	453	878	368	878	283	—	—	—	—
	71	852	768	852	683	852	598	852	514	852	429	852	344	—	—	—	—
	67	817	816	793	792	801	719	801	635	801	550	801	465	801	381	801	296
	62	817	816	793	792	769	768	745	744	740	700	740	615	740	531	740	446

* Rated performance is at sea level. Cooling capacities are gross cooling capacity.

TABLE 8 – COOLING PERFORMANCE DATA* – 60 TON MODEL (cont'd)

115° AIR ON CONDENSER COIL

CFM	ENTERING WB (°F)	CAPACITY (mbh) AT ENTERING DRY BULB (°F)															
		90		86		83		80		77		74		71		68	
		CAP	SHC	CAP	SHC	CAP	SHC	CAP	SHC	CAP	SHC	CAP	SHC	CAP	SHC	CAP	SHC
12000	75	756	413	756	374	756	335	756	296	756	257	—	—	—	—	—	—
	73	730	443	730	403	730	364	730	325	730	286	730	247	—	—	—	—
	71	705	471	705	432	705	393	705	354	705	315	705	275	—	—	—	—
	67	655	528	655	488	655	449	655	410	655	371	655	332	655	292	655	253
	62	599	599	595	556	595	516	595	477	595	438	595	399	595	360	595	320
14000	75	780	443	780	398	780	353	780	308	780	262	—	—	—	—	—	—
	73	754	477	754	432	754	386	754	341	754	296	754	251	—	—	—	—
	71	729	510	729	465	729	420	729	374	729	329	729	284	—	—	—	—
	67	680	576	680	530	680	485	680	440	680	395	680	349	680	304	680	259
	62	636	636	618	617	620	564	620	519	620	474	620	428	620	383	620	338
16000	75	798	472	798	421	798	370	798	319	798	268	—	—	—	—	—	—
	73	773	510	773	459	773	408	773	356	773	305	773	254	—	—	—	—
	71	748	548	748	496	748	445	748	394	748	343	748	292	—	—	—	—
	67	699	622	699	571	699	519	699	468	699	417	699	366	699	315	699	263
	62	668	667	648	647	628	628	640	558	640	507	640	456	640	405	640	354
18000	75	—	—	—	—	—	—	—	—	—	—	—	—	—	—	—	—
	73	789	542	789	485	789	428	789	371	789	314	789	257	—	—	—	—
	71	764	584	764	527	764	470	764	413	764	356	764	299	—	—	—	—
	67	715	666	715	609	715	552	715	495	715	438	715	381	715	324	715	267
	62	695	694	674	673	653	653	656	596	656	539	656	482	656	425	656	368
20000	75	—	—	—	—	—	—	—	—	—	—	—	—	—	—	—	—
	73	801	574	801	511	801	448	801	386	801	323	801	260	—	—	—	—
	71	776	619	776	557	776	494	776	431	776	368	776	306	—	—	—	—
	67	718	717	728	647	728	584	728	522	728	459	728	396	728	333	728	271
	62	718	717	696	696	675	675	669	633	669	570	669	507	669	445	669	382
22000	75	—	—	—	—	—	—	—	—	—	—	—	—	—	—	—	—
	73	—	—	—	—	—	—	—	—	—	—	—	—	—	—	—	—
	71	787	654	787	586	787	517	787	449	787	380	787	312	—	—	—	—
	67	738	737	738	684	738	616	738	547	738	479	738	410	738	342	738	274
	62	738	737	716	715	694	693	672	672	680	600	680	532	680	463	680	395
24000	75	—	—	—	—	—	—	—	—	—	—	—	—	—	—	—	—
	73	—	—	—	—	—	—	—	—	—	—	—	—	—	—	—	—
	71	796	688	796	614	796	540	796	466	796	392	796	318	—	—	—	—
	67	755	755	733	732	747	646	747	572	747	498	747	424	747	350	747	276
	62	755	755	733	732	711	710	688	688	689	629	689	555	689	481	689	407
26000	75	—	—	—	—	—	—	—	—	—	—	—	—	—	—	—	—
	73	—	—	—	—	—	—	—	—	—	—	—	—	—	—	—	—
	71	803	721	803	642	803	562	803	483	803	404	803	324	—	—	—	—
	67	771	770	748	747	755	676	755	596	755	517	755	438	755	358	755	279
	62	771	770	748	747	725	724	702	702	697	657	697	578	697	499	697	419
28000	75	—	—	—	—	—	—	—	—	—	—	—	—	—	—	—	—
	73	—	—	—	—	—	—	—	—	—	—	—	—	—	—	—	—
	71	—	—	—	—	—	—	—	—	—	—	—	—	—	—	—	—
	67	784	783	761	760	761	705	761	620	761	536	761	451	761	366	761	281
	62	784	783	761	760	738	737	715	714	691	691	703	600	703	516	703	431

* Rated performance is at sea level. Cooling capacities are gross cooling capacity.

Cooling Performance Data – 65 Ton Model

TABLE 9 – COOLING PERFORMANCE DATA* – 65 TON MODEL

85° AIR ON CONDENSER COIL

CFM	ENTERING WB (°F)	CAPACITY (mbh) AT ENTERING DRY BULB (°F)															
		90		86		83		80		77		74		71		68	
		CAP	SHC	CAP	SHC	CAP	SHC	CAP	SHC	CAP	SHC	CAP	SHC	CAP	SHC	CAP	SHC
14000	75	912	497	1012	587	912	450	912	404	912	357	912	310	—	—	—	—
	73	882	532	982	647	882	485	882	439	882	392	882	345	882	299	—	—
	71	852	566	953	706	852	520	852	473	852	427	852	380	852	333	—	—
	67	794	634	897	825	794	587	794	541	794	494	794	448	794	401	794	354
	62	724	724	867	867	723	668	723	622	723	575	723	528	723	482	723	435
16000	75	938	528	938	475	938	422	938	369	938	316	—	—	—	—	—	—
	73	908	567	908	514	908	461	908	409	908	356	908	303	—	—	—	—
	71	879	606	879	553	879	501	879	448	879	395	879	342	—	—	—	—
	67	821	683	821	630	821	578	821	525	821	472	821	419	821	367	821	314
	62	763	763	741	741	750	671	750	618	750	565	750	512	750	460	750	407
18000	75	959	557	959	498	959	440	959	381	959	322	—	—	—	—	—	—
	73	929	601	929	542	929	483	929	425	929	366	929	307	—	—	—	—
	71	900	645	900	586	900	527	900	468	900	409	900	350	—	—	—	—
	67	842	731	842	672	842	613	842	554	842	495	842	436	842	378	842	319
	62	796	796	773	773	772	717	772	659	772	600	772	541	772	482	772	423
20000	75	976	586	976	521	976	456	976	392	976	327	—	—	—	—	—	—
	73	946	634	946	569	946	504	946	440	946	375	946	310	—	—	—	—
	71	917	682	917	617	917	552	917	487	917	423	917	358	—	—	—	—
	67	860	776	860	712	860	647	860	582	860	517	860	452	860	388	860	323
	62	826	826	802	802	778	778	790	698	790	633	790	568	790	503	790	438
22000	75	990	614	990	544	990	473	990	402	990	332	—	—	—	—	—	—
	73	960	666	960	596	960	525	960	454	960	384	960	313	—	—	—	—
	71	931	718	931	647	931	577	931	506	931	436	931	365	—	—	—	—
	67	874	821	874	750	874	680	874	609	874	538	874	468	874	397	874	326
	62	851	851	827	827	802	802	805	735	805	665	805	594	805	523	805	453
24000	75	1002	642	1002	565	1002	489	1002	413	1002	336	—	—	—	—	—	—
	73	972	698	972	621	972	545	972	469	972	392	972	316	—	—	—	—
	71	943	754	943	677	943	601	943	524	943	448	943	372	—	—	—	—
	67	873	873	886	788	886	712	886	635	886	559	886	483	886	406	886	330
	62	873	873	848	848	823	823	817	772	817	696	817	619	817	543	817	466
26000	75	1012	669	1012	587	1012	505	1012	423	1012	340	—	—	—	—	—	—
	73	982	729	982	647	982	565	982	482	982	400	982	318	—	—	—	—
	71	953	789	953	706	953	624	953	542	953	460	953	378	—	—	—	—
	67	893	893	897	825	897	743	897	661	897	579	897	497	897	415	897	333
	62	893	893	867	867	842	842	816	816	828	726	828	643	828	561	828	479
28000	75	1021	696	1021	608	1021	520	1021	432	1021	345	—	—	—	—	—	—
	73	991	759	991	672	991	584	991	496	991	408	991	321	—	—	—	—
	71	962	823	962	735	962	647	962	560	962	472	962	384	—	—	—	—
	67	911	911	884	884	906	774	906	686	906	598	906	511	906	423	906	335
	62	911	911	884	884	858	858	832	832	837	755	837	667	837	579	837	492

* Rated performance is at sea level. Cooling capacities are gross cooling capacity.

TABLE 9 – COOLING PERFORMANCE DATA* – 65 TON MODEL (cont'd)

95° AIR ON CONDENSER COIL

CFM	ENTERING WB (°F)	CAPACITY (mbh) AT ENTERING DRY BULB (°F)															
		90		86		83		80		77		74		71		68	
		CAP	SHC	CAP	SHC	CAP	SHC	CAP	SHC	CAP	SHC	CAP	SHC	CAP	SHC	CAP	SHC
14000	75	878	484	878	438	878	391	878	344	878	298	—	—	—	—	—	—
	73	849	519	849	472	849	426	849	379	849	333	849	286	—	—	—	—
	71	821	554	821	507	821	460	821	414	821	367	821	321	—	—	—	—
	67	765	621	765	575	765	528	765	482	765	435	765	388	765	342	765	295
	62	704	704	698	656	698	610	698	563	698	516	698	470	698	423	698	377
16000	75	901	514	901	462	901	409	901	356	901	303	—	—	—	—	—	—
	73	873	554	873	501	873	448	873	396	873	343	873	290	—	—	—	—
	71	845	593	845	540	845	487	845	435	845	382	845	329	—	—	—	—
	67	790	670	790	617	790	565	790	512	790	459	790	406	790	353	790	301
	62	741	741	719	719	723	658	723	605	723	552	723	500	723	447	723	394
18000	75	920	544	920	485	920	426	920	367	920	309	—	—	—	—	—	—
	73	892	588	892	529	892	470	892	411	892	352	892	294	—	—	—	—
	71	864	631	864	572	864	513	864	455	864	396	864	337	—	—	—	—
	67	809	717	809	658	809	599	809	541	809	482	809	423	809	364	809	305
	62	772	772	750	750	743	704	743	645	743	586	743	528	743	469	743	410
20000	75	935	573	935	508	935	443	935	378	935	314	—	—	—	—	—	—
	73	907	621	907	556	907	491	907	426	907	361	907	297	—	—	—	—
	71	880	668	880	603	880	539	880	474	880	409	880	344	—	—	—	—
	67	825	763	825	698	825	633	825	568	825	503	825	439	825	374	825	309
	62	800	800	777	777	753	753	759	684	759	619	759	554	759	490	759	425
22000	75	948	601	948	530	948	460	948	389	948	318	—	—	—	—	—	—
	73	920	653	920	582	920	511	920	441	920	370	920	299	—	—	—	—
	71	893	704	893	634	893	563	893	492	893	422	893	351	—	—	—	—
	67	824	824	839	736	839	666	839	595	839	524	839	454	839	383	839	313
	62	824	824	800	800	776	776	773	721	773	651	773	580	773	509	773	439
24000	75	959	628	959	552	959	476	959	399	959	323	—	—	—	—	—	—
	73	931	684	931	608	931	531	931	455	931	378	931	302	—	—	—	—
	71	904	740	904	663	904	587	904	511	904	434	904	358	—	—	—	—
	67	845	845	850	774	850	698	850	621	850	545	850	468	850	392	850	316
	62	845	845	820	820	796	796	771	771	784	681	784	605	784	528	784	452
26000	75	969	655	969	573	969	491	969	409	969	327	—	—	—	—	—	—
	73	941	715	941	633	941	551	941	469	941	387	941	304	—	—	—	—
	71	913	775	913	693	913	610	913	528	913	446	913	364	—	—	—	—
	67	863	863	859	811	859	729	859	647	859	565	859	483	859	400	859	318
	62	863	863	838	838	813	813	788	788	794	711	794	629	794	547	794	465
28000	75	977	682	977	594	977	507	977	419	977	331	—	—	—	—	—	—
	73	949	746	949	658	949	570	949	482	949	395	949	307	—	—	—	—
	71	921	809	921	721	921	633	921	546	921	458	921	370	—	—	—	—
	67	880	880	854	854	867	760	867	672	867	584	867	496	867	409	867	321
	62	880	880	854	854	829	829	803	803	802	740	802	653	802	565	802	477

* Rated performance is at sea level. Cooling capacities are gross cooling capacity.

Cooling Performance Data – 65 Ton Model (cont'd.)

TABLE 9 – COOLING PERFORMANCE DATA* – 65 TON MODEL (cont'd)

105° AIR ON CONDENSER COIL

CFM	ENTERING WB (°F)	CAPACITY (mbh) AT ENTERING DRY BULB (°F)															
		90		86		83		80		77		74		71		68	
		CAP	SHC	CAP	SHC	CAP	SHC	CAP	SHC	CAP	SHC	CAP	SHC	CAP	SHC	CAP	SHC
14000	75	841	471	841	424	841	378	841	331	841	285	—	—	—	—	—	—
	73	814	506	814	459	814	413	814	366	814	319	814	273	—	—	—	—
	71	787	540	787	494	787	447	787	400	787	354	787	307	—	—	—	—
	67	735	608	735	561	735	515	735	468	735	422	735	375	735	328	735	282
	62	682	682	662	662	670	596	670	550	670	503	670	457	670	410	670	364
16000	75	863	501	863	448	863	396	863	343	863	290	—	—	—	—	—	—
	73	836	540	836	488	836	435	836	382	836	329	836	276	—	—	—	—
	71	809	579	809	527	809	474	809	421	809	368	809	315	—	—	—	—
	67	757	656	757	603	757	551	757	498	757	445	757	392	757	340	757	287
	62	717	717	696	696	693	644	693	591	693	539	693	486	693	433	693	380
18000	75	880	530	880	472	880	413	880	354	880	295	—	—	—	—	—	—
	73	853	574	853	515	853	456	853	397	853	339	853	280	—	—	—	—
	71	827	617	827	558	827	500	827	441	827	382	827	323	—	—	—	—
	67	775	703	775	644	775	585	775	526	775	468	775	409	775	350	775	291
	62	747	747	725	725	703	703	711	631	711	572	711	513	711	455	711	396
20000	75	894	559	894	494	894	429	894	365	894	300	—	—	—	—	—	—
	73	867	607	867	542	867	477	867	412	867	348	867	283	—	—	—	—
	71	841	654	841	589	841	525	841	460	841	395	841	330	—	—	—	—
	67	789	748	789	683	789	619	789	554	789	489	789	424	789	360	789	295
	62	772	772	750	750	727	727	726	669	726	605	726	540	726	475	726	410
22000	75	906	587	906	516	906	446	906	375	906	305	—	—	—	—	—	—
	73	879	639	879	568	879	497	879	427	879	356	879	285	—	—	—	—
	71	853	690	853	620	853	549	853	478	853	408	853	337	—	—	—	—
	67	795	795	801	722	801	651	801	581	801	510	801	439	801	369	801	298
	62	795	795	772	772	748	748	725	725	739	636	739	565	739	495	739	424
24000	75	916	615	916	538	916	462	916	385	916	309	—	—	—	—	—	—
	73	889	670	889	594	889	517	889	441	889	364	889	288	—	—	—	—
	71	863	726	863	649	863	573	863	496	863	420	863	343	—	—	—	—
	67	815	815	811	760	811	683	811	607	811	530	811	454	811	377	811	301
	62	815	815	791	791	767	767	743	743	749	666	749	590	749	514	749	437
26000	75	925	642	925	560	925	477	925	395	925	313	—	—	—	—	—	—
	73	898	701	898	619	898	537	898	455	898	373	898	290	—	—	—	—
	71	871	760	871	678	871	596	871	514	871	432	871	350	—	—	—	—
	67	832	832	808	808	820	714	820	632	820	550	820	468	820	386	820	304
	62	832	832	808	808	783	783	759	759	758	696	758	614	758	532	758	450
28000	75	932	668	932	581	932	493	932	405	932	317	—	—	—	—	—	—
	73	905	732	905	644	905	556	905	468	905	381	905	293	—	—	—	—
	71	879	795	879	707	879	619	879	531	879	444	879	356	—	—	—	—
	67	847	847	822	822	827	745	827	657	827	569	827	482	827	394	827	306
	62	847	847	822	822	798	798	773	773	765	725	765	637	765	550	765	462

* Rated performance is at sea level. Cooling capacities are gross cooling capacity.

TABLE 9 – COOLING PERFORMANCE DATA* – 65 TON MODEL (cont'd)

115° AIR ON CONDENSER COIL

CFM	ENTERING WB (°F)	CAPACITY (mbh) AT ENTERING DRY BULB (°F)															
		90		86		83		80		77		74		71		68	
		CAP	SHC	CAP	SHC	CAP	SHC	CAP	SHC	CAP	SHC	CAP	SHC	CAP	SHC	CAP	SHC
14000	75	803	457	803	411	803	364	803	318	803	271	—	—	—	—	—	—
	73	777	492	777	445	777	399	777	352	777	306	777	259	—	—	—	—
	71	752	526	752	480	752	433	752	387	752	340	752	293	—	—	—	—
	67	702	594	702	547	702	501	702	454	702	408	702	361	702	314	702	268
	62	658	658	638	638	641	583	641	536	641	489	641	443	641	396	641	350
16000	75	822	487	822	435	822	382	822	329	822	276	—	—	—	—	—	—
	73	797	526	797	474	797	421	797	368	797	315	797	263	—	—	—	—
	71	772	565	772	512	772	460	772	407	772	354	772	301	—	—	—	—
	67	722	642	722	589	722	536	722	484	722	431	722	378	722	325	722	272
	62	691	691	670	670	650	650	661	577	661	524	661	471	661	419	661	366
18000	75	—	—	—	—	—	—	—	—	—	—	—	—	—	—	—	—
	73	813	560	813	501	813	442	813	383	813	324	813	266	—	—	—	—
	71	787	603	787	544	787	485	787	426	787	368	787	309	—	—	—	—
	67	738	688	738	629	738	571	738	512	738	453	738	394	738	335	738	276
	62	719	719	698	698	676	676	678	616	678	557	678	499	678	440	678	381
20000	75	—	—	—	—	—	—	—	—	—	—	—	—	—	—	—	—
	73	—	—	—	—	—	—	—	—	—	—	—	—	—	—	—	—
	71	800	640	800	575	800	510	800	445	800	381	800	316	—	—	—	—
	67	743	743	751	669	751	604	751	539	751	474	751	409	751	345	751	280
	62	743	743	721	721	699	699	691	654	691	589	691	525	691	460	691	395
22000	75	—	—	—	—	—	—	—	—	—	—	—	—	—	—	—	—
	73	—	—	—	—	—	—	—	—	—	—	—	—	—	—	—	—
	71	811	676	811	605	811	534	811	464	811	393	811	322	—	—	—	—
	67	764	764	762	707	762	636	762	566	762	495	762	424	762	354	762	283
	62	764	764	742	742	719	719	696	696	702	621	702	550	702	479	702	409
24000	75	—	—	—	—	—	—	—	—	—	—	—	—	—	—	—	—
	73	—	—	—	—	—	—	—	—	—	—	—	—	—	—	—	—
	71	820	711	820	635	820	558	820	482	820	405	820	329	—	—	—	—
	67	783	783	760	760	771	668	771	592	771	515	771	439	771	362	771	286
	62	783	783	760	760	736	736	713	713	712	651	712	574	712	498	712	422
26000	75	—	—	—	—	—	—	—	—	—	—	—	—	—	—	—	—
	73	—	—	—	—	—	—	—	—	—	—	—	—	—	—	—	—
	71	—	—	—	—	—	—	—	—	—	—	—	—	—	—	—	—
	67	799	799	775	775	779	699	779	617	779	535	779	453	779	371	779	289
	62	799	799	775	775	752	752	728	728	720	680	720	598	720	516	720	434
28000	75	—	—	—	—	—	—	—	—	—	—	—	—	—	—	—	—
	73	—	—	—	—	—	—	—	—	—	—	—	—	—	—	—	—
	71	—	—	—	—	—	—	—	—	—	—	—	—	—	—	—	—
	67	813	813	789	789	786	730	786	642	786	554	786	467	786	379	786	291
	62	813	813	789	789	765	765	741	741	717	717	726	622	726	534	726	446

* Rated performance is at sea level. Cooling capacities are gross cooling capacity.

Cooling Performance Data – 70 Ton Model

TABLE 10 – COOLING PERFORMANCE DATA* – 70 TON MODEL

85° AIR ON CONDENSER COIL

CFM	ENTERING WB (°F)	CAPACITY (mbh) AT ENTERING DRY BULB (°F)															
		90		86		83		80		77		74		71		68	
		CAP	SHC	CAP	SHC	CAP	SHC	CAP	SHC	CAP	SHC	CAP	SHC	CAP	SHC	CAP	SHC
16000	75	1000	547	1000	495	1000	443	1000	461	1000	409	—	—	—	—	—	—
	73	966	585	966	534	966	482	966	499	966	447	966	395	—	—	—	—
	71	933	623	933	572	933	520	933	537	933	485	933	433	—	—	—	—
	67	867	698	867	646	867	594	867	611	867	560	867	508	867	456	867	404
	62	791	791	778	751	787	683	778	717	787	648	787	597	787	545	787	493
18000	75	1025	577	1025	519	1025	461	1025	403	1025	346	—	—	—	—	—	—
	73	991	620	991	562	991	504	991	446	991	388	991	331	—	—	—	—
	71	958	662	958	604	958	547	958	489	958	431	958	373	—	—	—	—
	67	893	746	893	688	893	630	893	572	893	514	893	456	893	399	893	341
	62	829	829	811	792	813	730	813	673	813	615	813	557	813	499	813	441
20000	75	1046	606	1046	542	1046	478	1046	415	1046	351	—	—	—	—	—	—
	73	1012	653	1012	589	1012	526	1012	462	1012	398	1012	334	—	—	—	—
	71	979	700	979	636	979	572	979	509	979	445	979	381	—	—	—	—
	67	914	792	914	728	914	664	914	601	914	537	914	473	914	410	914	346
	62	861	861	836	836	835	776	835	712	835	649	835	585	835	521	835	458
22000	75	1063	634	1063	565	1063	495	1063	426	1063	356	—	—	—	—	—	—
	73	1030	685	1030	616	1030	546	1030	477	1030	407	1030	338	—	—	—	—
	71	997	736	997	667	997	597	997	528	997	458	997	389	—	—	—	—
	67	932	837	932	767	932	698	932	628	932	559	932	489	932	420	932	350
	62	890	890	864	864	848	824	853	751	853	681	853	612	853	542	853	473
24000	75	1078	662	1078	586	1078	511	1078	436	1078	361	—	—	—	—	—	—
	73	1045	717	1045	642	1045	566	1045	491	1045	416	1045	341	—	—	—	—
	71	1012	772	1012	696	1012	621	1012	546	1012	471	1012	396	—	—	—	—
	67	933	895	948	805	948	730	948	655	948	580	948	504	948	429	948	354
	62	916	916	889	889	862	862	869	788	869	713	869	637	869	562	869	487
26000	75	1091	689	1091	608	1091	527	1091	446	1091	365	—	—	—	—	—	—
	73	1058	748	1058	667	1058	586	1058	505	1058	424	1058	344	—	—	—	—
	71	1025	806	1025	726	1025	645	1025	564	1025	483	1025	403	—	—	—	—
	67	953	923	961	842	961	761	961	681	961	600	961	519	961	438	961	358
	62	939	939	911	911	884	884	870	837	882	743	882	662	882	581	882	501
28000	75	1102	715	1102	629	1102	542	1102	456	1102	370	—	—	—	—	—	—
	73	1069	778	1069	692	1069	605	1069	519	1069	433	1069	346	—	—	—	—
	71	1036	840	1036	754	1036	668	1036	582	1036	495	1036	409	—	—	—	—
	67	970	950	972	879	972	792	972	706	972	620	972	533	972	447	972	361
	62	959	959	931	931	903	903	887	860	894	773	894	686	894	600	894	514
30000	75	1111	741	1111	649	1111	558	1111	466	1111	374	—	—	—	—	—	—
	73	1078	808	1078	716	1078	624	1078	532	1078	441	1078	349	—	—	—	—
	71	1046	874	1046	782	1046	690	1046	599	1046	507	1046	415	—	—	—	—
	67	977	977	967	926	982	822	982	731	982	639	982	547	982	455	982	364
	62	977	977	949	949	920	920	901	882	904	801	904	710	904	618	904	526

* Rated performance is at sea level. Cooling capacities are gross cooling capacity.

TABLE 10 – COOLING PERFORMANCE DATA* – 70 TON MODEL (cont'd)

95° AIR ON CONDENSER COIL

CFM	ENTERING WB (°F)	CAPACITY (mbh) AT ENTERING DRY BULB (°F)															
		90		86		83		80		77		74		71		68	
		CAP	SHC	CAP	SHC	CAP	SHC	CAP	SHC	CAP	SHC	CAP	SHC	CAP	SHC	CAP	SHC
16000	75	963	534	963	482	963	430	963	378	963	326	—	—	—	—	—	—
	73	931	572	931	520	931	468	931	417	931	365	931	313	—	—	—	—
	71	900	610	900	559	900	507	900	455	900	403	900	351	—	—	—	—
	67	838	685	838	633	838	581	838	530	838	478	838	426	838	374	838	322
	62	771	771	757	734	762	671	762	619	762	568	762	516	762	464	762	412
18000	75	986	563	986	505	986	447	986	390	986	332	—	—	—	—	—	—
	73	954	606	954	548	954	490	954	433	954	375	954	317	—	—	—	—
	71	923	649	923	591	923	533	923	475	923	417	923	359	—	—	—	—
	67	861	732	861	675	861	617	861	559	861	501	861	443	861	385	861	328
	62	807	807	788	774	786	718	786	660	786	602	786	545	786	487	786	429
20000	75	1005	592	1005	528	1005	464	1005	401	1005	337	—	—	—	—	—	—
	73	973	639	973	575	973	512	973	448	973	384	973	320	—	—	—	—
	71	942	686	942	622	942	558	942	495	942	431	942	367	—	—	—	—
	67	881	778	881	714	881	651	881	587	881	523	881	460	881	396	881	332
	62	837	837	813	813	799	773	806	699	806	636	806	572	806	508	806	445
22000	75	1021	620	1021	550	1021	481	1021	411	1021	342	—	—	—	—	—	—
	73	989	671	989	601	989	532	989	463	989	393	989	324	—	—	—	—
	71	958	722	958	652	958	583	958	513	958	444	958	374	—	—	—	—
	67	897	823	897	753	897	684	897	614	897	545	897	475	897	406	897	336
	62	865	865	839	839	822	804	823	737	823	668	823	598	823	529	823	459
24000	75	1034	647	1034	572	1034	497	1034	422	1034	347	—	—	—	—	—	—
	73	1003	702	1003	627	1003	552	1003	477	1003	402	1003	326	—	—	—	—
	71	972	757	972	682	972	607	972	532	972	456	972	381	—	—	—	—
	67	903	871	911	791	911	716	911	640	911	565	911	490	911	415	911	340
	62	889	889	863	863	837	837	837	774	837	699	837	624	837	548	837	473
26000	75	1046	674	1046	593	1046	513	1046	432	1046	351	—	—	—	—	—	—
	73	1014	733	1014	652	1014	571	1014	491	1014	410	1014	329	—	—	—	—
	71	983	792	983	711	983	630	983	549	983	469	983	388	—	—	—	—
	67	921	899	923	828	923	747	923	666	923	585	923	505	923	424	923	343
	62	910	910	883	883	857	857	842	814	849	729	849	648	849	567	849	486
28000	75	1056	700	1056	614	1056	528	1056	442	1056	355	—	—	—	—	—	—
	73	1024	763	1024	677	1024	591	1024	504	1024	418	1024	332	—	—	—	—
	71	993	826	993	739	993	653	993	567	993	480	993	394	—	—	—	—
	67	929	929	919	879	933	777	933	691	933	605	933	519	933	432	933	346
	62	929	929	902	902	875	875	857	837	860	758	860	672	860	585	860	499
30000	75	1064	726	1064	635	1064	543	1064	451	1064	359	—	—	—	—	—	—
	73	1033	793	1033	701	1033	609	1033	518	1033	426	1033	334	—	—	—	—
	71	1002	859	1002	767	1002	676	1002	584	1002	492	1002	400	—	—	—	—
	67	946	946	933	901	942	807	942	716	942	624	942	532	942	440	942	349
	62	946	946	918	918	891	891	863	863	869	787	869	695	869	603	869	511

* Rated performance is at sea level. Cooling capacities are gross cooling capacity.

Cooling Performance Data – 70 Ton Model (cont'd.)

TABLE 10 – COOLING PERFORMANCE DATA* – 70 TON MODEL (cont'd)

105° AIR ON CONDENSER COIL

CFM	ENTERING WB (°F)	CAPACITY (mbh) AT ENTERING DRY BULB (°F)															
		90		86		83		80		77		74		71		68	
		CAP	SHC	CAP	SHC	CAP	SHC	CAP	SHC	CAP	SHC	CAP	SHC	CAP	SHC	CAP	SHC
16000	75	923	519	923	467	923	415	923	364	923	312	—	—	—	—	—	—
	73	893	558	893	506	893	454	893	402	893	350	893	299	—	—	—	—
	71	864	596	864	544	864	492	864	441	864	389	864	337	—	—	—	—
	67	806	671	806	620	806	568	806	516	806	464	806	412	806	360	806	308
	62	749	749	734	715	735	658	735	607	735	555	735	503	735	451	735	399
18000	75	943	548	943	491	943	433	943	375	943	317	—	—	—	—	—	—
	73	914	591	914	533	914	476	914	418	914	360	914	302	—	—	—	—
	71	885	634	885	576	885	518	885	460	885	403	885	345	—	—	—	—
	67	827	718	827	660	827	602	827	545	827	487	827	429	827	371	827	313
	62	782	782	759	759	748	719	757	647	757	589	757	531	757	473	757	415
20000	75	960	577	960	513	960	449	960	386	960	322	—	—	—	—	—	—
	73	931	624	931	560	931	496	931	433	931	369	931	305	—	—	—	—
	71	902	671	902	607	902	543	902	480	902	416	902	352	—	—	—	—
	67	845	763	845	700	845	636	845	572	845	509	845	445	845	381	845	317
	62	811	811	787	787	772	751	775	685	775	622	775	558	775	494	775	430
22000	75	975	605	975	535	975	466	975	396	975	327	—	—	—	—	—	—
	73	945	656	945	586	945	517	945	447	945	378	945	308	—	—	—	—
	71	916	707	916	637	916	568	916	498	916	429	916	359	—	—	—	—
	67	850	818	859	738	859	668	859	599	859	530	859	460	859	391	859	321
	62	836	836	812	812	787	787	790	723	790	653	790	584	790	514	790	445
24000	75	987	632	987	557	987	482	987	406	987	331	—	—	—	—	—	—
	73	957	687	957	612	957	537	957	461	957	386	957	311	—	—	—	—
	71	928	742	928	666	928	591	928	516	928	441	928	366	—	—	—	—
	67	869	846	871	775	871	700	871	625	871	550	871	475	871	400	871	324
	62	859	859	834	834	809	809	795	767	802	684	802	608	802	533	802	458
26000	75	997	659	997	578	997	497	997	416	997	336	—	—	—	—	—	—
	73	968	717	968	637	968	556	968	475	968	394	968	314	—	—	—	—
	71	939	776	939	695	939	615	939	534	939	453	939	372	—	—	—	—
	67	878	878	882	812	882	731	882	650	882	570	882	489	882	408	882	327
	62	878	878	853	853	827	827	810	790	813	713	813	633	813	552	813	471
28000	75	1006	685	1006	599	1006	512	1006	426	1006	340	—	—	—	—	—	—
	73	977	748	977	661	977	575	977	489	977	402	977	316	—	—	—	—
	71	948	810	948	724	948	637	948	551	948	465	948	378	—	—	—	—
	67	896	896	883	852	891	762	891	675	891	589	891	503	891	416	891	330
	62	896	896	870	870	844	844	818	818	823	742	823	656	823	570	823	484
30000	75	1014	711	1014	619	1014	527	1014	436	1014	344	—	—	—	—	—	—
	73	985	777	985	685	985	594	985	502	985	410	985	318	—	—	—	—
	71	956	843	956	752	956	660	956	568	956	476	956	384	—	—	—	—
	67	912	912	896	873	899	791	899	700	899	608	899	516	899	424	899	333
	62	912	912	885	885	859	859	832	832	819	785	831	679	831	587	831	496

* Rated performance is at sea level. Cooling capacities are gross cooling capacity.

TABLE 10 – COOLING PERFORMANCE DATA* – 70 TON MODEL (cont'd)

115° AIR ON CONDENSER COIL

CFM	ENTERING WB (°F)	CAPACITY (mbh) AT ENTERING DRY BULB (°F)															
		90		86		83		80		77		74		71		68	
		CAP	SHC	CAP	SHC	CAP	SHC	CAP	SHC	CAP	SHC	CAP	SHC	CAP	SHC	CAP	SHC
16000	75	879	504	879	452	879	400	879	348	879	296	—	—	—	—	—	—
	73	852	542	852	490	852	439	852	387	852	335	852	283	—	—	—	—
	71	824	581	824	529	824	477	824	425	824	373	824	321	—	—	—	—
	67	771	656	771	605	771	553	771	501	771	449	771	397	771	345	771	293
	62	724	724	708	695	705	644	705	593	705	541	705	489	705	437	705	385
18000	75	897	533	897	475	897	417	897	359	897	301	—	—	—	—	—	—
	73	870	575	870	518	870	460	870	402	870	344	870	286	—	—	—	—
	71	843	618	843	560	843	502	843	445	843	387	843	329	—	—	—	—
	67	789	702	789	645	789	587	789	529	789	471	789	413	789	356	789	298
	62	755	755	733	733	720	697	724	632	724	574	724	516	724	458	724	401
20000	75	912	561	912	497	912	433	912	370	912	306	—	—	—	—	—	—
	73	885	608	885	544	885	480	885	417	885	353	885	289	—	—	—	—
	71	858	655	858	591	858	527	858	463	858	400	858	336	—	—	—	—
	67	794	762	805	684	805	620	805	556	805	493	805	429	805	365	805	301
	62	781	781	759	759	742	728	740	670	740	606	740	542	740	479	740	415
22000	75	925	588	925	519	925	449	925	380	925	311	—	—	—	—	—	—
	73	897	639	897	570	897	500	897	431	897	361	897	292	—	—	—	—
	71	870	690	870	621	870	551	870	482	870	412	870	343	—	—	—	—
	67	814	791	817	722	817	652	817	583	817	513	817	444	817	374	817	305
	62	805	805	781	781	758	758	745	718	753	637	753	568	753	498	753	429
24000	75	935	616	935	540	935	465	935	390	935	315	—	—	—	—	—	—
	73	908	670	908	595	908	520	908	445	908	370	908	295	—	—	—	—
	71	881	725	881	650	881	575	881	500	881	424	881	349	—	—	—	—
	67	825	825	828	759	828	684	828	608	828	533	828	458	828	383	828	308
	62	825	825	801	801	777	777	761	742	764	667	764	592	764	517	764	442
26000	75	945	642	945	562	945	481	945	400	945	319	—	—	—	—	—	—
	73	917	701	917	620	917	539	917	459	917	378	917	297	—	—	—	—
	71	890	759	890	679	890	598	890	517	890	436	890	356	—	—	—	—
	67	844	844	830	801	838	714	838	634	838	553	838	472	838	391	838	311
	62	844	844	819	819	795	795	770	770	774	697	774	616	774	535	774	454
28000	75	953	669	953	582	953	496	953	410	953	323	—	—	—	—	—	—
	73	926	731	926	645	926	558	926	472	926	386	926	299	—	—	—	—
	71	899	793	899	707	899	621	899	534	899	448	899	362	—	—	—	—
	67	860	860	843	823	846	745	846	658	846	572	846	486	846	399	846	313
	62	860	860	835	835	810	810	785	785	772	740	782	639	782	553	782	467
30000	75	—	—	—	—	—	—	—	—	—	—	—	—	—	—	—	—
	73	933	760	933	669	933	577	933	485	933	393	933	302	—	—	—	—
	71	906	826	906	735	906	643	906	551	906	459	906	368	—	—	—	—
	67	874	874	849	849	853	774	853	683	853	591	853	499	853	407	853	316
	62	874	874	849	849	824	824	798	798	783	757	789	662	789	570	789	479

* Rated performance is at sea level. Cooling capacities are gross cooling capacity.

Cooling Performance Data – 75 Ton Model

TABLE 11 – COOLING PERFORMANCE DATA* – 75 TON MODEL

85° AIR ON CONDENSER COIL

CFM	ENTERING WB (°F)	CAPACITY (mbh) AT ENTERING DRY BULB (°F)															
		90		86		83		80		77		74		71		68	
		CAP	SHC	CAP	SHC	CAP	SHC	CAP	SHC	CAP	SHC	CAP	SHC	CAP	SHC	CAP	SHC
16000	73	978	593	978	541	978	488	978	436	978	384	978	331	—	—	—	—
	71	945	631	945	579	945	527	945	474	945	422	945	370	—	—	—	—
	67	880	707	880	655	880	602	880	550	880	498	880	445	880	393	880	341
	62	804	804	800	745	800	693	800	640	800	588	800	536	800	483	800	431
18000	75	1038	584	1038	526	1038	467	1038	409	1038	351	—	—	—	—	—	—
	73	1004	628	1004	569	1004	511	1004	452	1004	394	1004	336	—	—	—	—
	71	971	671	971	612	971	554	971	496	971	437	971	379	—	—	—	—
	67	906	755	906	697	906	639	906	580	906	522	906	463	906	405	906	347
20000	62	842	842	825	805	826	741	826	682	826	624	826	566	826	507	826	449
	75	1059	614	1059	549	1059	485	1059	420	1059	356	—	—	—	—	—	—
	73	1025	661	1025	597	1025	533	1025	468	1025	404	1025	339	—	—	—	—
	71	992	709	992	644	992	580	992	516	992	451	992	387	—	—	—	—
22000	67	928	802	928	738	928	674	928	609	928	545	928	481	928	416	928	352
	62	876	876	850	850	849	787	849	723	849	658	849	594	849	530	849	465
	75	1076	642	1076	572	1076	502	1076	431	1076	361	—	—	—	—	—	—
	73	1043	694	1043	624	1043	554	1043	483	1043	413	1043	343	—	—	—	—
24000	71	1010	746	1010	676	1010	605	1010	535	1010	465	1010	394	—	—	—	—
	67	946	848	946	778	946	707	946	637	946	567	946	497	946	426	946	356
	62	906	906	879	879	863	838	867	762	867	692	867	621	867	551	867	481
	75	1091	670	1091	594	1091	518	1091	442	1091	366	—	—	—	—	—	—
26000	73	1058	726	1058	650	1058	574	1058	498	1058	422	1058	346	—	—	—	—
	71	1025	782	1025	706	1025	630	1025	554	1025	478	1025	402	—	—	—	—
	67	949	909	961	816	961	740	961	664	961	588	961	512	961	436	961	360
	62	932	932	905	905	884	868	883	800	883	723	883	647	883	571	883	495
28000	75	1104	698	1104	616	1104	534	1104	452	1104	371	—	—	—	—	—	—
	73	1071	758	1071	676	1071	594	1071	512	1071	430	1071	349	—	—	—	—
	71	1038	818	1038	736	1038	654	1038	572	1038	490	1038	408	—	—	—	—
	67	969	939	974	854	974	773	974	691	974	609	974	527	974	445	974	363
30000	62	956	956	928	928	900	900	886	851	896	754	896	673	896	591	896	509
	75	1115	725	1115	637	1115	550	1115	462	1115	375	—	—	—	—	—	—
	73	1082	789	1082	701	1082	614	1082	526	1082	439	1082	351	—	—	—	—
	71	1050	852	1050	765	1050	677	1050	590	1050	502	1050	415	—	—	—	—
30000	67	987	966	986	891	986	804	986	716	986	629	986	541	986	454	986	366
	62	977	977	948	948	919	919	902	875	908	785	908	697	908	610	908	522
	75	1125	752	1125	659	1125	565	1125	472	1125	379	—	—	—	—	—	—
	73	1092	819	1092	726	1092	633	1092	540	1092	447	1092	354	—	—	—	—
30000	71	1059	887	1059	794	1059	701	1059	607	1059	514	1059	421	—	—	—	—
	67	996	996	983	942	995	835	995	742	995	649	995	555	995	462	995	369
	62	996	996	966	966	937	937	917	898	918	814	918	721	918	628	918	535

* Rated performance is at sea level. Cooling capacities are gross cooling capacity.

TABLE 11 – COOLING PERFORMANCE DATA* – 75 TON MODEL (cont'd)

95° AIR ON CONDENSER COIL

CFM	ENTERING WB (°F)	CAPACITY (mbh) AT ENTERING DRY BULB (°F)															
		90		86		83		80		77		74		71		68	
		CAP	SHC	CAP	SHC	CAP	SHC	CAP	SHC	CAP	SHC	CAP	SHC	CAP	SHC	CAP	SHC
16000	73	943	579	943	527	943	474	943	422	943	370	943	317	—	—	—	—
	71	911	618	911	565	911	513	911	461	911	408	911	356	—	—	—	—
	67	849	694	849	641	849	589	849	537	849	484	849	432	849	380	849	327
	62	783	783	769	745	774	680	774	628	774	576	774	523	774	471	774	419
18000	75	997	570	997	511	997	453	997	395	997	336	—	—	—	—	—	—
	73	966	613	966	555	966	497	966	438	966	380	966	321	—	—	—	—
	71	935	657	935	598	935	540	935	481	935	423	935	365	—	—	—	—
	67	873	742	873	683	873	625	873	566	873	508	873	450	873	391	873	333
20000	62	819	819	801	785	798	728	798	669	798	611	798	553	798	494	798	436
	75	1017	599	1017	535	1017	470	1017	406	1017	342	—	—	—	—	—	—
	73	985	647	985	582	985	518	985	454	985	389	985	325	—	—	—	—
	71	954	694	954	630	954	566	954	501	954	437	954	372	—	—	—	—
22000	67	893	788	893	724	893	659	893	595	893	531	893	466	893	402	893	337
	62	851	851	826	826	812	785	819	709	819	645	819	580	819	516	819	452
	75	1033	628	1033	557	1033	487	1033	417	1033	346	—	—	—	—	—	—
	73	1001	679	1001	609	1001	539	1001	469	1001	398	1001	328	—	—	—	—
24000	71	970	731	970	661	970	591	970	520	970	450	970	380	—	—	—	—
	67	909	833	909	763	909	693	909	623	909	552	909	482	909	412	909	341
	62	879	879	853	853	835	816	836	748	836	677	836	607	836	537	836	467
	75	1046	656	1046	579	1046	503	1046	427	1046	351	—	—	—	—	—	—
26000	73	1015	711	1015	635	1015	559	1015	483	1015	407	1015	331	—	—	—	—
	71	984	767	984	691	984	615	984	539	984	463	984	387	—	—	—	—
	67	917	885	923	802	923	725	923	649	923	573	923	497	923	421	923	345
	62	904	904	877	877	851	851	850	785	850	709	850	633	850	557	850	481
28000	75	1058	683	1058	601	1058	519	1058	437	1058	356	—	—	—	—	—	—
	73	1027	743	1027	661	1027	579	1027	497	1027	415	1027	334	—	—	—	—
	71	996	802	996	721	996	639	996	557	996	475	996	393	—	—	—	—
	67	935	913	935	839	935	757	935	676	935	594	935	512	935	430	935	348
30000	62	926	926	899	899	872	872	856	828	862	740	862	658	862	576	862	494
	75	1068	710	1068	622	1068	535	1068	447	1068	360	—	—	—	—	—	—
	73	1037	774	1037	686	1037	599	1037	511	1037	424	1037	336	—	—	—	—
	71	1006	837	1006	750	1006	662	1006	575	1006	487	1006	400	—	—	—	—
30000	67	945	945	934	893	946	789	946	701	946	614	946	526	946	439	946	351
	62	945	945	918	918	890	890	871	851	872	769	872	682	872	594	872	507
	75	1077	737	1077	643	1077	550	1077	457	1077	364	—	—	—	—	—	—
	73	1046	804	1046	711	1046	618	1046	525	1046	432	1046	339	—	—	—	—
30000	71	1015	871	1015	778	1015	685	1015	592	1015	499	1015	406	—	—	—	—
	67	963	963	948	916	954	819	954	726	954	633	954	540	954	447	954	354
	62	963	963	935	935	907	907	879	879	882	799	882	706	882	613	882	519

* Rated performance is at sea level. Cooling capacities are gross cooling capacity.

Cooling Performance Data – 75 Ton Model (cont'd.)

TABLE 11 – COOLING PERFORMANCE DATA* – 75 TON MODEL (cont'd)

105° AIR ON CONDENSER COIL

CFM	ENTERING WB (°F)	CAPACITY (mbh) AT ENTERING DRY BULB (°F)															
		90		86		83		80		77		74		71		68	
		CAP	SHC	CAP	SHC	CAP	SHC	CAP	SHC	CAP	SHC	CAP	SHC	CAP	SHC	CAP	SHC
16000	73	903	564	903	512	903	460	903	407	903	355	903	303	—	—	—	—
	71	874	603	874	551	874	498	874	446	874	394	874	341	—	—	—	—
	67	816	679	816	627	816	575	816	522	816	470	816	418	816	365	816	313
	62	760	760	745	725	746	667	746	615	746	562	746	510	746	458	746	405
18000	75	954	555	954	496	954	438	954	379	954	321	—	—	—	—	—	—
	73	924	598	924	540	924	481	924	423	924	365	924	306	—	—	—	—
	71	895	641	895	583	895	525	895	466	895	408	895	349	—	—	—	—
	67	838	727	838	668	838	610	838	552	838	493	838	435	838	376	838	318
20000	62	794	794	771	771	768	714	768	655	768	597	768	538	768	480	768	422
	75	971	584	971	519	971	455	971	390	971	326	—	—	—	—	—	—
	73	941	631	941	567	941	502	941	438	941	374	941	309	—	—	—	—
	71	912	679	912	614	912	550	912	486	912	421	912	357	—	—	—	—
22000	67	855	773	855	708	855	644	855	580	855	515	855	451	855	386	855	322
	62	824	824	800	800	784	763	786	694	786	630	786	566	786	501	786	437
	75	985	612	985	542	985	471	985	401	985	331	—	—	—	—	—	—
	73	956	664	956	593	956	523	956	453	956	383	956	312	—	—	—	—
24000	71	927	715	927	645	927	575	927	504	927	434	927	364	—	—	—	—
	67	863	830	870	747	870	677	870	607	870	537	870	466	870	396	870	326
	62	850	850	825	825	800	800	801	732	801	662	801	592	801	522	801	451
	75	997	640	997	564	997	488	997	411	997	335	—	—	—	—	—	—
26000	73	968	696	968	619	968	543	968	467	968	391	968	315	—	—	—	—
	71	939	751	939	675	939	599	939	523	939	447	939	371	—	—	—	—
	67	882	859	882	786	882	709	882	633	882	557	882	481	882	405	882	329
	62	873	873	847	847	822	822	807	779	814	693	814	617	814	541	814	465
28000	75	1008	667	1008	585	1008	503	1008	422	1008	340	—	—	—	—	—	—
	73	979	727	979	645	979	563	979	481	979	399	979	318	—	—	—	—
	71	950	786	950	705	950	623	950	541	950	459	950	377	—	—	—	—
	67	893	893	893	823	893	741	893	659	893	577	893	496	893	414	893	332
30000	62	893	893	867	867	841	841	823	803	825	724	825	642	825	560	825	478
	75	1017	694	1017	607	1017	519	1017	432	1017	344	—	—	—	—	—	—
	73	988	758	988	670	988	583	988	495	988	408	988	320	—	—	—	—
	71	959	821	959	734	959	646	959	559	959	471	959	384	—	—	—	—
30000	67	911	911	897	865	902	772	902	685	902	597	902	510	902	422	902	335
	62	911	911	885	885	858	858	832	832	834	753	834	666	834	578	834	491
	75	—	—	—	—	—	—	—	—	—	—	—	—	—	—	—	—
	73	996	788	996	695	996	602	996	509	996	416	996	322	—	—	—	—
30000	71	967	855	967	762	967	669	967	576	967	483	967	390	—	—	—	—
	67	928	928	910	887	910	803	910	710	910	617	910	524	910	430	910	337
	62	928	928	901	901	874	874	847	847	832	797	842	689	842	596	842	503

* Rated performance is at sea level. Cooling capacities are gross cooling capacity.

TABLE 11 – COOLING PERFORMANCE DATA* – 75 TON MODEL (cont'd)

115° AIR ON CONDENSER COIL

CFM	ENTERING WB (°F)	CAPACITY (mbh) AT ENTERING DRY BULB (°F)															
		90		86		83		80		77		74		71		68	
		CAP	SHC	CAP	SHC	CAP	SHC	CAP	SHC	CAP	SHC	CAP	SHC	CAP	SHC	CAP	SHC
16000	73	861	548	861	496	861	443	861	391	861	339	861	287	—	—	—	—
	71	833	587	833	535	833	482	833	430	833	378	833	325	—	—	—	—
	67	780	664	780	611	780	559	780	507	780	454	780	402	780	350	780	297
	62	734	734	717	704	715	652	715	600	715	547	715	495	715	443	715	390
18000	75	906	538	906	480	906	422	906	363	906	305	—	—	—	—	—	—
	73	879	582	879	523	879	465	879	407	879	348	879	290	—	—	—	—
	71	852	625	852	567	852	508	852	450	852	391	852	333	—	—	—	—
	67	799	711	799	652	799	594	799	535	799	477	799	419	799	360	799	302
20000	62	766	766	743	743	730	707	734	640	734	581	734	523	734	465	734	406
	75	921	567	921	503	921	438	921	374	921	310	—	—	—	—	—	—
	73	894	615	894	550	894	486	894	422	894	357	894	293	—	—	—	—
	71	867	662	867	598	867	533	867	469	867	405	867	340	—	—	—	—
22000	67	805	773	814	692	814	627	814	563	814	499	814	434	814	370	814	305
	62	793	793	770	770	752	738	750	678	750	614	750	550	750	485	750	421
	75	934	595	934	525	934	455	934	384	934	314	—	—	—	—	—	—
	73	907	647	907	577	907	506	907	436	907	366	907	296	—	—	—	—
24000	71	880	698	880	628	880	558	880	488	880	417	880	347	—	—	—	—
	67	826	803	827	731	827	660	827	590	827	520	827	449	827	379	827	309
	62	817	817	793	793	770	770	756	728	763	646	763	575	763	505	763	435
	75	945	623	945	547	945	471	945	395	945	319	—	—	—	—	—	—
26000	73	918	679	918	603	918	526	918	450	918	374	918	298	—	—	—	—
	71	891	734	891	658	891	582	891	506	891	430	891	354	—	—	—	—
	67	838	838	838	768	838	692	838	616	838	540	838	464	838	388	838	312
	62	838	838	814	814	790	790	773	753	774	676	774	600	774	524	774	448
28000	75	955	650	955	569	955	487	955	405	955	323	—	—	—	—	—	—
	73	927	710	927	628	927	546	927	464	927	382	927	301	—	—	—	—
	71	900	769	900	687	900	606	900	524	900	442	900	360	—	—	—	—
	67	857	857	842	813	848	724	848	642	848	560	848	478	848	397	848	315
30000	62	857	857	832	832	807	807	782	782	784	706	784	625	784	543	784	461
	75	—	—	—	—	—	—	—	—	—	—	—	—	—	—	—	—
	73	936	741	936	653	936	566	936	478	936	391	936	303	—	—	—	—
	71	909	804	909	716	909	629	909	541	909	454	909	366	—	—	—	—
30000	67	874	874	856	836	856	755	856	667	856	580	856	492	856	405	856	317
	62	874	874	848	848	823	823	798	798	783	751	792	648	792	561	792	473
	75	—	—	—	—	—	—	—	—	—	—	—	—	—	—	—	—
	73	943	771	943	678	943	585	943	492	943	398	943	305	—	—	—	—
30000	71	916	838	916	745	916	652	916	559	916	465	916	372	—	—	—	—
	67	889	889	863	863	863	785	863	692	863	599	863	506	863	413	863	320
	62	889	889	863	863	837	837	811	811	795	769	799	672	799	578	799	485

* Rated performance is at sea level. Cooling capacities are gross cooling capacity.

Cooling Performance Data – 80 Ton Model

TABLE 12 – COOLING PERFORMANCE DATA* – 80 TON MODEL

85° AIR ON CONDENSER COIL

CFM	ENTERING WB (°F)	CAPACITY (mbh) AT ENTERING DRY BULB (°F)															
		90		86		83		80		77		74		71		68	
		CAP	SHC	CAP	SHC	CAP	SHC	CAP	SHC	CAP	SHC	CAP	SHC	CAP	SHC	CAP	SHC
16000	75	1065	566	1065	516	1065	466	1065	415	1065	365	—	—	—	—	—	—
	73	1027	603	1027	553	1027	503	1027	452	1027	402	1027	351	—	—	—	—
	71	989	640	989	589	989	539	989	488	989	438	989	388	—	—	—	—
	67	915	710	915	660	915	609	915	559	915	509	915	458	915	408	915	358
	62	0	0	825	743	825	693	825	643	825	592	825	542	825	491	825	441
18000	75	1096	597	1096	540	1096	484	1096	428	1096	372	—	—	—	—	—	—
	73	1058	638	1058	582	1058	526	1058	469	1058	413	1058	357	—	—	—	—
	71	1021	679	1021	623	1021	566	1021	510	1021	454	1021	398	—	—	—	—
	67	947	758	947	702	947	646	947	590	947	534	947	478	947	421	947	365
	62	860	860	857	797	857	741	857	685	857	629	857	573	857	517	857	460
20000	75	1122	626	1122	564	1122	502	1122	440	1122	378	—	—	—	—	—	—
	73	1084	671	1084	609	1084	547	1084	485	1084	424	1084	362	—	—	—	—
	71	1047	716	1047	654	1047	592	1047	531	1047	469	1047	407	—	—	—	—
	67	973	805	973	743	973	681	973	619	973	557	973	495	973	433	973	372
	62	897	897	871	871	883	787	883	725	883	664	883	602	883	540	883	478
22000	75	1144	654	1144	586	1144	519	1144	451	1144	384	—	—	—	—	—	—
	73	1106	703	1106	636	1106	568	1106	501	1106	433	1106	366	—	—	—	—
	71	1069	752	1069	685	1069	618	1069	550	1069	483	1069	415	—	—	—	—
	67	996	849	996	782	996	714	996	647	996	579	996	512	996	444	996	377
	62	930	930	902	902	906	832	906	764	906	697	906	629	906	562	906	494
24000	75	1162	681	1162	608	1162	535	1162	462	1162	389	—	—	—	—	—	—
	73	1125	734	1125	661	1125	588	1125	515	1125	442	1125	369	—	—	—	—
	71	1088	788	1088	715	1088	642	1088	569	1088	496	1088	423	—	—	—	—
	67	1015	893	1015	820	1015	747	1015	674	1015	601	1015	528	1015	455	1015	382
	62	959	959	931	931	925	874	925	801	925	728	925	655	925	582	925	509
26000	75	1178	707	1178	629	1178	550	1178	472	1178	394	—	—	—	—	—	—
	73	1141	765	1141	686	1141	608	1141	529	1141	451	1141	373	—	—	—	—
	71	1104	822	1104	744	1104	665	1104	587	1104	508	1104	430	—	—	—	—
	67	1031	935	1031	856	1031	778	1031	700	1031	621	1031	543	1031	464	1031	386
	62	985	985	956	956	927	927	942	837	942	759	942	680	942	602	942	523
28000	75	1191	733	1191	650	1191	566	1191	482	1191	398	—	—	—	—	—	—
	73	1154	795	1154	711	1154	627	1154	543	1154	459	1154	375	—	—	—	—
	71	1117	855	1117	772	1117	688	1117	604	1117	520	1117	436	—	—	—	—
	67	1045	976	1045	892	1045	808	1045	725	1045	641	1045	557	1045	473	1045	389
	62	1008	1008	979	979	949	949	956	872	956	788	956	704	956	621	956	537
30000	75	1203	759	1203	670	1203	581	1203	491	1203	402	—	—	—	—	—	—
	73	1166	824	1166	735	1166	645	1166	556	1166	467	1166	378	—	—	—	—
	71	1129	888	1129	799	1129	710	1129	621	1129	532	1129	443	—	—	—	—
	67	1029	1029	1057	927	1057	838	1057	749	1057	660	1057	571	1057	482	1057	392
	62	1029	1029	999	999	969	969	969	906	969	817	969	728	969	639	969	550
32000	75	1213	784	1213	689	1213	595	1213	499	1213	402	—	—	—	—	—	—
	73	1176	852	1176	758	1176	664	1176	568	1176	472	1176	375	1176	278	1176	181
	71	1140	921	1140	826	1140	732	1140	636	1140	540	1140	443	1140	346	1140	249
	67	1048	1048	1067	962	1067	867	1067	771	1067	675	1067	579	1067	483	1067	387
	62	1048	1048	1017	1017	986	986	1017	1017	986	986	955	955	980	845	980	751
34000	75	1222	808	1222	709	1222	609	1222	510	1222	410	—	—	—	—	—	—
	73	1185	881	1185	781	1185	681	1185	582	1185	482	1185	383	—	—	—	—
	71	1149	952	1149	853	1149	753	1149	654	1149	554	1149	455	—	—	—	—
	67	1065	1065	1077	995	1077	896	1077	796	1077	697	1077	597	1077	498	1077	398
	62	1065	1065	1034	1034	1002	1002	971	971	989	872	989	773	989	673	989	574

* Rated performance is at sea level. Cooling capacities are gross cooling capacity.

TABLE 12 – COOLING PERFORMANCE DATA* – 80 TON MODEL (cont'd)

95° AIR ON CONDENSER COIL

CFM	ENTERING WB (°F)	CAPACITY (mbh) AT ENTERING DRY BULB (°F)															
		90		86		83		80		77		74		71		68	
		CAP	SHC	CAP	SHC	CAP	SHC	CAP	SHC	CAP	SHC	CAP	SHC	CAP	SHC	CAP	SHC
16000	75	1029	553	1029	503	1029	452	1029	402	1029	351	—	—	—	—	—	—
	73	994	590	994	540	994	489	994	439	994	389	994	338	—	—	—	—
	71	958	627	958	576	958	526	958	476	958	425	958	375	—	—	—	—
	67	888	698	888	648	888	597	888	547	888	497	888	446	888	396	888	346
	62	801	801	803	733	803	682	803	632	803	582	803	531	803	481	803	431
18000	75	1058	583	1058	526	1058	470	1058	414	1058	358	—	—	—	—	—	—
	73	1022	624	1022	568	1022	512	1022	456	1022	399	1022	343	—	—	—	—
	71	987	665	987	609	987	553	987	497	987	440	987	384	—	—	—	—
	67	917	746	917	689	917	633	917	577	917	521	917	465	917	409	917	352
	62	840	840	833	786	833	730	833	674	833	617	833	561	833	505	833	449
20000	75	1081	611	1081	549	1081	487	1081	425	1081	364	—	—	—	—	—	—
	73	1046	657	1046	595	1046	533	1046	471	1046	409	1046	347	—	—	—	—
	71	1011	702	1011	640	1011	578	1011	517	1011	455	1011	393	—	—	—	—
	67	941	791	941	729	941	668	941	606	941	544	941	482	941	420	941	358
	62	875	875	849	849	857	775	857	713	857	651	857	589	857	528	857	466
22000	75	1101	639	1101	571	1101	504	1101	436	1101	369	—	—	—	—	—	—
	73	1066	689	1066	621	1066	554	1066	486	1066	419	1066	351	—	—	—	—
	71	1031	738	1031	670	1031	603	1031	536	1031	468	1031	401	—	—	—	—
	67	962	835	962	768	962	700	962	633	962	565	962	498	962	430	962	363
	62	906	906	879	879	878	819	878	751	878	684	878	616	878	549	878	481
24000	75	1117	666	1117	593	1117	520	1117	447	1117	374	—	—	—	—	—	—
	73	1082	719	1082	646	1082	573	1082	500	1082	427	1082	354	—	—	—	—
	71	1048	773	1048	700	1048	627	1048	554	1048	481	1048	408	—	—	—	—
	67	979	878	979	805	979	732	979	659	979	586	979	513	979	440	979	367
	62	933	933	906	906	879	879	895	788	895	715	895	642	895	569	895	496
26000	75	1132	692	1132	614	1132	535	1132	457	1132	378	—	—	—	—	—	—
	73	1097	750	1097	671	1097	593	1097	514	1097	436	1097	357	—	—	—	—
	71	1062	807	1062	728	1062	650	1062	571	1062	493	1062	415	—	—	—	—
	67	994	920	994	842	994	763	994	685	994	606	994	528	994	449	994	371
	62	958	958	930	930	902	902	910	823	910	745	910	666	910	588	910	509
28000	75	1144	718	1144	634	1144	550	1144	466	1144	383	—	—	—	—	—	—
	73	1109	779	1109	695	1109	612	1109	528	1109	444	1109	360	—	—	—	—
	71	1074	840	1074	756	1074	672	1074	589	1074	505	1074	421	—	—	—	—
	67	980	980	1006	877	1006	793	1006	710	1006	626	1006	542	1006	458	1006	374
	62	980	980	951	951	922	922	923	858	923	774	923	690	923	606	923	522
30000	75	1155	743	1155	654	1155	565	1155	476	1155	387	—	—	—	—	—	—
	73	1120	808	1120	719	1120	630	1120	541	1120	452	1120	362	—	—	—	—
	71	1085	873	1085	784	1085	695	1085	605	1085	516	1085	427	—	—	—	—
	67	999	999	1017	912	1017	823	1017	734	1017	645	1017	555	1017	466	1017	377
	62	999	999	970	970	941	941	911	911	935	802	935	713	935	624	935	535
32000	75	1164	768	1164	674	1164	580	1164	485	1164	391	—	—	—	—	—	—
	73	1129	837	1129	742	1129	648	1129	554	1129	459	1129	365	—	—	—	—
	71	1094	905	1094	811	1094	716	1094	622	1094	527	1094	433	—	—	—	—
	67	1017	1017	1027	946	1027	852	1027	757	1027	663	1027	569	1027	474	1027	380
	62	1017	1017	987	987	957	957	927	927	944	830	944	736	944	641	944	547
34000	75	1172	793	1172	693	1172	594	1172	494	1172	395	—	—	—	—	—	—
	73	1137	865	1137	765	1137	666	1137	566	1137	467	1137	367	—	—	—	—
	71	1103	937	1103	837	1103	737	1103	638	1103	538	1103	439	—	—	—	—
	67	1033	1033	1035	980	1035	880	1035	781	1035	681	1035	582	1035	482	1035	382
	62	1033	1033	1003	1003	972	972	942	942	953	857	953	758	953	658	953	559

* Rated performance is at sea level. Cooling capacities are gross cooling capacity.

Cooling Performance Data – 80 Ton Model (cont'd.)

TABLE 12 – COOLING PERFORMANCE DATA* – 80 TON MODEL (cont'd)

105° AIR ON CONDENSER COIL

CFM	ENTERING WB (°F)	CAPACITY (mbh) AT ENTERING DRY BULB (°F)															
		90		86		83		80		77		74		71		68	
		CAP	SHC	CAP	SHC	CAP	SHC	CAP	SHC	CAP	SHC	CAP	SHC	CAP	SHC	CAP	SHC
16000	75	989	538	989	487	989	437	989	387	989	336	—	—	—	—	—	—
	73	956	575	956	525	956	475	956	424	956	374	956	323	—	—	—	—
	71	923	612	923	562	923	512	923	461	923	411	923	361	—	—	—	—
	67	858	685	858	634	858	584	858	534	858	483	858	433	858	383	858	332
	62	781	781	779	721	779	671	779	620	779	570	779	519	779	469	779	419
18000	75	1014	567	1014	511	1014	455	1014	398	1014	342	—	—	—	—	—	—
	73	981	609	981	552	981	496	981	440	981	384	981	328	—	—	—	—
	71	949	650	949	594	949	538	949	482	949	425	949	369	—	—	—	—
	67	884	731	884	675	884	619	884	563	884	507	884	451	884	394	884	338
	62	818	818	794	794	806	717	806	661	806	605	806	548	806	492	806	436
20000	75	1035	595	1035	533	1035	471	1035	409	1035	347	—	—	—	—	—	—
	73	1002	641	1002	579	1002	517	1002	455	1002	393	1002	332	—	—	—	—
	71	970	686	970	625	970	563	970	501	970	439	970	377	—	—	—	—
	67	906	776	906	714	906	653	906	591	906	529	906	467	906	405	906	343
	62	850	850	826	826	828	761	828	699	828	638	828	576	828	514	828	452
22000	75	1053	622	1053	555	1053	487	1053	420	1053	352	—	—	—	—	—	—
	73	1020	672	1020	605	1020	537	1020	470	1020	402	1020	335	—	—	—	—
	71	988	722	988	654	988	587	988	519	988	452	988	384	—	—	—	—
	67	924	820	924	752	924	685	924	617	924	550	924	482	924	415	924	347
	62	879	879	853	853	828	828	846	737	846	669	846	602	846	534	846	467
24000	75	1067	649	1067	576	1067	503	1067	430	1067	357	—	—	—	—	—	—
	73	1035	703	1035	630	1035	557	1035	484	1035	411	1035	338	—	—	—	—
	71	1002	756	1002	683	1002	610	1002	537	1002	464	1002	391	—	—	—	—
	67	939	862	939	789	939	716	939	643	939	570	939	497	939	424	939	351
	62	904	904	878	878	852	852	862	773	862	700	862	627	862	554	862	481
26000	75	1080	675	1080	597	1080	518	1080	440	1080	361	—	—	—	—	—	—
	73	1047	733	1047	654	1047	576	1047	497	1047	419	1047	340	—	—	—	—
	71	1015	790	1015	712	1015	633	1015	555	1015	476	1015	398	—	—	—	—
	67	952	904	952	825	952	747	952	668	952	590	952	512	952	433	952	355
	62	927	927	900	900	873	873	875	808	875	729	875	651	875	572	875	494
28000	75	1091	701	1091	617	1091	533	1091	449	1091	366	—	—	—	—	—	—
	73	1058	762	1058	678	1058	595	1058	511	1058	427	1058	343	—	—	—	—
	71	1026	823	1026	739	1026	656	1026	572	1026	488	1026	404	—	—	—	—
	67	947	947	963	861	963	777	963	693	963	609	963	525	963	441	963	358
	62	947	947	920	920	892	892	887	842	887	758	887	674	887	590	887	507
30000	75	1100	726	1100	637	1100	548	1100	459	1100	370	—	—	—	—	—	—
	73	1068	791	1068	702	1068	613	1068	524	1068	435	1068	345	—	—	—	—
	71	1036	856	1036	767	1036	677	1036	588	1036	499	1036	410	—	—	—	—
	67	965	965	973	895	973	806	973	717	973	628	973	539	973	449	973	360
	62	965	965	937	937	909	909	881	881	897	786	897	697	897	608	897	519
32000	75	1109	751	1109	657	1109	562	1109	468	1109	374	—	—	—	—	—	—
	73	1076	819	1076	725	1076	631	1076	536	1076	442	1076	348	—	—	—	—
	71	1044	888	1044	793	1044	699	1044	605	1044	510	1044	416	—	—	—	—
	67	981	981	981	929	981	835	981	740	981	646	981	552	981	457	981	363
	62	981	981	953	953	925	925	896	896	905	814	905	719	905	625	905	530
34000	75	1116	776	1116	676	1116	576	1116	477	1116	377	—	—	—	—	—	—
	73	1084	847	1084	748	1084	648	1084	549	1084	449	1084	350	—	—	—	—
	71	1052	919	1052	820	1052	720	1052	621	1052	521	1052	421	—	—	—	—
	67	996	996	967	967	989	863	989	763	989	664	989	564	989	465	989	365
	62	996	996	967	967	938	938	910	910	913	841	913	741	913	641	913	542

* Rated performance is at sea level. Cooling capacities are gross cooling capacity.

TABLE 12 – COOLING PERFORMANCE DATA* – 80 TON MODEL (cont'd)

115° AIR ON CONDENSER COIL

CFM	ENTERING WB (°F)	CAPACITY (mbh) AT ENTERING DRY BULB (°F)															
		90		86		83		80		77		74		71		68	
		CAP	SHC	CAP	SHC	CAP	SHC	CAP	SHC	CAP	SHC	CAP	SHC	CAP	SHC	CAP	SHC
16000	75	943	521	943	470	943	420	943	370	943	319	—	—	—	—	—	—
	73	913	559	913	508	913	458	913	407	913	357	913	307	—	—	—	—
	71	883	596	883	546	883	495	883	445	883	395	883	344	—	—	—	—
	67	823	669	823	619	823	569	823	518	823	468	823	418	823	367	823	317
	62	757	757	751	707	751	657	751	607	751	556	751	506	751	455	751	405
18000	75	965	549	965	493	965	437	965	381	965	325	—	—	—	—	—	—
	73	935	591	935	535	935	479	935	423	935	367	935	310	—	—	—	—
	71	905	633	905	577	905	521	905	464	905	408	905	352	—	—	—	—
	67	846	715	846	659	846	603	846	547	846	490	846	434	846	378	846	322
	62	791	791	769	769	774	702	774	646	774	590	774	534	774	478	774	421
20000	75	983	577	983	515	983	453	983	391	983	329	—	—	—	—	—	—
	73	953	623	953	561	953	499	953	437	953	376	953	314	—	—	—	—
	71	923	669	923	607	923	545	923	483	923	421	923	359	—	—	—	—
	67	865	759	865	697	865	636	865	574	865	512	865	450	865	388	865	326
	62	821	821	798	798	793	746	793	684	793	622	793	560	793	498	793	436
22000	75	998	604	998	537	998	469	998	402	998	334	—	—	—	—	—	—
	73	968	654	968	587	968	519	968	452	968	384	968	317	—	—	—	—
	71	938	704	938	636	938	569	938	501	938	434	938	366	—	—	—	—
	67	880	802	880	735	880	667	880	600	880	532	880	465	880	397	880	330
	62	847	847	823	823	799	799	810	720	810	653	810	585	810	518	810	450
24000	75	1011	631	1011	558	1011	485	1011	412	1011	339	—	—	—	—	—	—
	73	981	684	981	611	981	538	981	465	981	392	981	319	—	—	—	—
	71	951	738	951	665	951	592	951	519	951	446	951	373	—	—	—	—
	67	894	844	894	771	894	698	894	625	894	552	894	479	894	406	894	333
	62	871	871	846	846	821	821	823	756	823	683	823	610	823	537	823	464
26000	75	1022	657	1022	578	1022	500	1022	421	1022	343	—	—	—	—	—	—
	73	992	714	992	636	992	557	992	479	992	400	992	322	—	—	—	—
	71	963	771	963	693	963	615	963	536	963	458	963	379	—	—	—	—
	67	891	891	905	807	905	729	905	650	905	572	905	493	905	415	905	336
	62	891	891	866	866	840	840	835	790	835	712	835	633	835	555	835	477
28000	75	1031	682	1031	598	1031	514	1031	431	1031	347	—	—	—	—	—	—
	73	1002	743	1002	660	1002	576	1002	492	1002	408	1002	324	—	—	—	—
	71	972	804	972	721	972	637	972	553	972	469	972	385	—	—	—	—
	67	910	910	915	842	915	758	915	674	915	591	915	507	915	423	915	339
	62	910	910	884	884	858	858	832	832	845	740	845	656	845	573	845	489
30000	75	1040	707	1040	618	1040	529	1040	440	1040	351	—	—	—	—	—	—
	73	1010	772	1010	683	1010	594	1010	505	1010	416	1010	326	—	—	—	—
	71	981	837	981	748	981	658	981	569	981	480	981	391	—	—	—	—
	67	926	926	923	876	923	787	923	698	923	609	923	520	923	431	923	342
	62	926	926	900	900	873	873	847	847	853	768	853	679	853	590	853	501
32000	75	1047	732	1047	638	1047	543	1047	449	1047	355	—	—	—	—	—	—
	73	1017	800	1017	706	1017	612	1017	517	1017	423	1017	329	—	—	—	—
	71	988	869	988	774	988	680	988	586	988	491	988	397	—	—	—	—
	67	941	941	914	914	930	816	930	721	930	627	930	533	930	438	930	344
	62	941	941	914	914	887	887	860	860	861	795	861	701	861	606	861	512
34000	75	1054	757	1054	657	1054	557	1054	458	1054	358	—	—	—	—	—	—
	73	1024	828	1024	729	1024	629	1024	530	1024	430	1024	331	—	—	—	—
	71	994	900	994	801	994	701	994	601	994	502	994	402	—	—	—	—
	67	954	954	927	927	937	844	937	744	937	645	937	545	937	446	937	346
	62	954	954	927	927	899	899	872	872	867	822	867	722	867	623	867	523

* Rated performance is at sea level. Cooling capacities are gross cooling capacity.

Cooling Performance Data – 85 Ton Model

TABLE 13 – COOLING PERFORMANCE DATA* – 85 TON MODEL

85° AIR ON CONDENSER COIL

CFM	ENTERING WB (°F)	CAPACITY (mbh) AT ENTERING DRY BULB (°F)															
		90		86		83		80		77		74		71		68	
		CAP	SHC	CAP	SHC	CAP	SHC	CAP	SHC	CAP	SHC	CAP	SHC	CAP	SHC	CAP	SHC
16000	75	1112	591	1112	539	1112	487	1112	539	1112	487	1112	434	1112	382	0	0
	73	1073	630	1073	578	1073	525	1073	578	1073	525	1073	473	1073	421	1073	368
	71	1034	668	1034	616	1034	563	1034	616	1034	563	1034	511	1034	459	1034	406
	67	958	742	958	689	958	637	958	689	958	637	958	585	958	533	958	480
	62	857	857	865	777	865	725	865	777	865	725	865	672	865	620	865	568
18000	75	1145	623	1145	564	1145	506	1145	448	1145	389	—	—	—	—	—	—
	73	1106	666	1106	608	1106	549	1106	491	1106	433	1106	374	—	—	—	—
	71	1067	709	1067	650	1067	592	1067	534	1067	475	1067	417	—	—	—	—
	67	991	792	991	734	991	675	991	617	991	559	991	500	991	442	991	384
	62	901	901	899	834	899	775	899	717	899	658	899	600	899	542	899	483
20000	75	1172	653	1172	589	1172	524	1172	460	1172	396	—	—	—	—	—	—
	73	1133	701	1133	636	1133	572	1133	508	1133	443	1133	379	—	—	—	—
	71	1095	748	1095	684	1095	619	1095	555	1095	491	1095	426	—	—	—	—
	67	1019	841	1019	776	1019	712	1019	648	1019	583	1019	519	1019	454	1019	390
	62	940	940	913	913	927	823	927	759	927	695	927	630	927	566	927	502
22000	75	1194	682	1194	612	1194	542	1194	472	1194	401	—	—	—	—	—	—
	73	1156	734	1156	664	1156	594	1156	524	1156	453	1156	383	—	—	—	—
	71	1117	786	1117	716	1117	645	1117	575	1117	505	1117	435	—	—	—	—
	67	1042	888	1042	817	1042	747	1042	677	1042	606	1042	536	1042	466	1042	396
	62	975	975	946	946	950	870	950	800	950	729	950	659	950	589	950	518
24000	75	1213	711	1213	635	1213	559	1213	483	1213	407	—	—	—	—	—	—
	73	1175	767	1175	691	1175	615	1175	539	1175	463	1175	387	—	—	—	—
	71	1137	823	1137	747	1137	671	1137	595	1137	518	1137	442	—	—	—	—
	67	1062	933	1062	857	1062	781	1062	705	1062	629	1062	552	1062	476	1062	400
	62	1006	1006	976	976	971	915	971	839	971	762	971	686	971	610	971	534
26000	75	1230	739	1230	657	1230	575	1230	493	1230	411	—	—	—	—	—	—
	73	1191	799	1191	717	1191	635	1191	553	1191	472	1191	390	—	—	—	—
	71	1153	859	1153	777	1153	695	1153	613	1153	532	1153	450	—	—	—	—
	67	1079	977	1079	895	1079	814	1079	732	1079	650	1079	568	1079	486	1079	404
	62	1034	1034	1003	1003	973	973	988	876	988	794	988	713	988	631	988	549
28000	75	1244	766	1244	679	1244	591	1244	504	1244	416	—	—	—	—	—	—
	73	1205	830	1205	743	1205	655	1205	568	1205	480	1205	393	—	—	—	—
	71	1168	894	1168	807	1168	719	1168	632	1168	544	1168	457	—	—	—	—
	67	1093	1021	1093	933	1093	846	1093	758	1093	671	1093	583	1093	496	1093	408
	62	1059	1059	1027	1027	996	996	1003	913	1003	825	1003	738	1003	650	1003	563
30000	75	1256	793	1256	700	1256	607	1256	514	1256	421	—	—	—	—	—	—
	73	1218	861	1218	768	1218	675	1218	582	1218	489	1218	395	—	—	—	—
	71	1180	929	1180	836	1180	742	1180	649	1180	556	1180	463	—	—	—	—
	67	1081	1081	1106	970	1106	877	1106	784	1106	691	1106	598	1106	504	1106	411
	62	1081	1081	1049	1049	1017	1017	1016	949	1016	856	1016	762	1016	669	1016	576
32000	75	1267	819	1267	721	1267	622	1267	523	1267	425	—	—	—	—	—	—
	73	1229	891	1229	793	1229	694	1229	595	1229	497	1229	398	—	—	—	—
	71	1191	963	1191	864	1191	765	1191	667	1191	568	1191	470	—	—	—	—
	67	1101	1101	1117	1006	1117	908	1117	809	1117	710	1117	612	1117	513	1117	414
	62	1101	1101	1069	1069	1036	1036	1004	1004	1027	885	1027	786	1027	688	1027	589

* Rated performance is at sea level. Cooling capacities are gross cooling capacity.

TABLE 13 – COOLING PERFORMANCE DATA* – 85 TON MODEL (cont'd)

95° AIR ON CONDENSER COIL

CFM	ENTERING WB (°F)	CAPACITY (mbh) AT ENTERING DRY BULB (°F)															
		90		86		83		80		77		74		71		68	
		CAP	SHC	CAP	SHC	CAP	SHC	CAP	SHC	CAP	SHC	CAP	SHC	CAP	SHC	CAP	SHC
16000	75	1074	577	1074	525	1074	472	1074	420	1074	368	—	—	—	—	—	—
	73	1037	616	1037	563	1037	511	1037	459	1037	406	1037	354	—	—	—	—
	71	1001	654	1001	602	1001	549	1001	497	1001	445	1001	392	—	—	—	—
	67	929	729	929	676	929	624	929	572	929	520	929	467	929	415	929	363
	62	838	838	842	765	842	713	842	661	842	608	842	556	842	504	842	451
18000	75	1104	608	1104	549	1104	491	1104	433	1104	374	—	—	—	—	—	—
	73	1067	651	1067	593	1067	534	1067	476	1067	418	1067	359	—	—	—	—
	71	1031	694	1031	636	1031	577	1031	519	1031	461	1031	402	—	—	—	—
	67	960	778	960	720	960	662	960	603	960	545	960	486	960	428	960	370
	62	880	880	872	821	872	763	872	704	872	646	872	587	872	529	872	471
20000	75	1128	638	1128	573	1128	509	1128	444	1128	380	—	—	—	—	—	—
	73	1092	685	1092	621	1092	557	1092	492	1092	428	1092	363	—	—	—	—
	71	1056	733	1056	668	1056	604	1056	540	1056	475	1056	411	—	—	—	—
	67	985	826	985	762	985	697	985	633	985	569	985	504	985	440	985	375
	62	917	917	890	890	898	810	898	746	898	681	898	617	898	553	898	488
22000	75	1148	667	1148	596	1148	526	1148	456	1148	385	—	—	—	—	—	—
	73	1112	719	1112	648	1112	578	1112	508	1112	437	1112	367	—	—	—	—
	71	1076	770	1076	700	1076	630	1076	560	1076	489	1076	419	—	—	—	—
	67	1006	872	1006	802	1006	732	1006	662	1006	591	1006	521	1006	451	1006	380
	62	950	950	922	922	920	856	920	785	920	715	920	645	920	575	920	504
24000	75	1166	695	1166	619	1166	543	1166	467	1166	390	—	—	—	—	—	—
	73	1130	751	1130	675	1130	599	1130	523	1130	447	1130	371	—	—	—	—
	71	1094	807	1094	731	1094	655	1094	579	1094	502	1094	426	—	—	—	—
	67	1024	917	1024	841	1024	765	1024	689	1024	613	1024	537	1024	461	1024	385
	62	979	979	950	950	921	921	938	824	938	748	938	672	938	596	938	519
26000	75	1180	723	1180	641	1180	559	1180	477	1180	395	—	—	—	—	—	—
	73	1144	783	1144	701	1144	619	1144	537	1144	455	1144	374	—	—	—	—
	71	1109	843	1109	761	1109	679	1109	597	1109	515	1109	433	—	—	—	—
	67	1039	961	1039	880	1039	798	1039	716	1039	634	1039	552	1039	470	1039	388
	62	1005	1005	975	975	946	946	954	861	954	779	954	697	954	616	954	534
28000	75	1193	750	1193	662	1193	575	1193	487	1193	400	—	—	—	—	—	—
	73	1157	814	1157	726	1157	639	1157	551	1157	464	1157	376	—	—	—	—
	71	1122	878	1122	790	1122	703	1122	615	1122	528	1122	440	—	—	—	—
	67	1028	1028	1052	917	1052	829	1052	742	1052	654	1052	567	1052	479	1052	392
	62	1028	1028	998	998	968	968	967	897	967	810	967	722	967	635	967	547
30000	75	1204	776	1204	683	1204	590	1204	497	1204	404	—	—	—	—	—	—
	73	1168	844	1168	751	1168	658	1168	565	1168	472	1168	379	—	—	—	—
	71	1133	912	1133	819	1133	726	1133	633	1133	540	1133	447	—	—	—	—
	67	1049	1049	1063	954	1063	860	1063	767	1063	674	1063	581	1063	488	1063	395
	62	1049	1049	1018	1018	987	987	957	957	979	840	979	747	979	653	979	560
32000	75	1214	803	1214	704	1214	605	1214	507	1214	408	—	—	—	—	—	—
	73	1178	874	1178	776	1178	677	1178	579	1178	480	1178	381	—	—	—	—
	71	1143	946	1143	847	1143	749	1143	650	1143	551	1143	453	—	—	—	—
	67	1068	1068	1073	990	1073	891	1073	792	1073	694	1073	595	1073	496	1073	398
	62	1068	1068	1036	1036	1005	1005	974	974	989	869	989	770	989	672	989	573

* Rated performance is at sea level. Cooling capacities are gross cooling capacity.

Cooling Performance Data – 85 Ton Model (cont'd.)

TABLE 13 – COOLING PERFORMANCE DATA* – 85 TON MODEL (cont'd)

105° AIR ON CONDENSER COIL

CFM	ENTERING WB (°F)	CAPACITY (mbh) AT ENTERING DRY BULB (°F)															
		90		86		83		80		77		74		71		68	
		CAP	SHC	CAP	SHC	CAP	SHC	CAP	SHC	CAP	SHC	CAP	SHC	CAP	SHC	CAP	SHC
16000	75	1031	561	1031	508	1031	456	1031	404	1031	351	—	—	—	—	—	—
	73	997	600	997	548	997	495	997	443	997	391	997	338	—	—	—	—
	71	963	639	963	586	963	534	963	482	963	429	963	377	—	—	—	—
	67	897	714	897	662	897	610	897	557	897	505	897	453	897	400	897	348
	62	816	816	815	752	815	700	815	648	815	595	815	543	815	491	815	438
18000	75	1057	591	1057	533	1057	474	1057	416	1057	357	—	—	—	—	—	—
	73	1024	635	1024	576	1024	518	1024	459	1024	401	1024	343	—	—	—	—
	71	990	678	990	620	990	561	990	503	990	444	990	386	—	—	—	—
	67	924	763	924	705	924	646	924	588	924	529	924	471	924	413	924	354
	62	856	856	831	831	843	749	843	690	843	632	843	573	843	515	843	457
20000	75	1079	620	1079	556	1079	492	1079	427	1079	363	—	—	—	—	—	—
	73	1045	668	1045	604	1045	540	1045	475	1045	411	1045	346	—	—	—	—
	71	1012	716	1012	652	1012	587	1012	523	1012	458	1012	394	—	—	—	—
	67	946	810	946	746	946	681	946	617	946	552	946	488	946	424	946	359
	62	890	890	864	864	866	795	866	731	866	666	866	602	866	538	866	473
22000	75	1097	649	1097	579	1097	508	1097	438	1097	368	—	—	—	—	—	—
	73	1063	701	1063	631	1063	561	1063	490	1063	420	1063	350	—	—	—	—
	71	1030	753	1030	683	1030	612	1030	542	1030	472	1030	402	—	—	—	—
	67	965	856	965	785	965	715	965	645	965	574	965	504	965	434	965	364
	62	920	920	894	894	885	840	885	770	885	699	885	629	885	559	885	489
24000	75	1112	677	1112	601	1112	525	1112	449	1112	373	—	—	—	—	—	—
	73	1079	733	1079	657	1079	581	1079	505	1079	429	1079	353	—	—	—	—
	71	1046	789	1046	713	1046	637	1046	561	1046	485	1046	409	—	—	—	—
	67	981	900	981	824	981	748	981	672	981	596	981	520	981	444	981	367
	62	947	947	920	920	892	892	901	808	901	731	901	655	901	579	901	503
26000	75	1125	705	1125	623	1125	541	1125	459	1125	377	—	—	—	—	—	—
	73	1092	765	1092	683	1092	601	1092	519	1092	437	1092	356	—	—	—	—
	71	1059	825	1059	743	1059	661	1059	579	1059	497	1059	416	—	—	—	—
	67	994	944	994	862	994	780	994	698	994	616	994	535	994	453	994	371
	62	971	971	943	943	915	915	915	844	915	762	915	681	915	599	915	517
28000	75	1137	732	1137	644	1137	557	1137	469	1137	382	—	—	—	—	—	—
	73	1103	796	1103	708	1103	621	1103	533	1103	446	1103	358	—	—	—	—
	71	1070	860	1070	772	1070	685	1070	597	1070	510	1070	422	—	—	—	—
	67	993	993	1006	899	1006	811	1006	724	1006	636	1006	549	1006	461	1006	374
	62	993	993	964	964	935	935	927	880	927	793	927	705	927	618	927	530
30000	75	1147	758	1147	665	1147	572	1147	479	1147	386	—	—	—	—	—	—
	73	1113	826	1113	733	1113	640	1113	547	1113	454	1113	361	—	—	—	—
	71	1080	894	1080	801	1080	708	1080	615	1080	521	1080	428	—	—	—	—
	67	1012	1012	1016	935	1016	842	1016	749	1016	656	1016	563	1016	470	1016	377
	62	1012	1012	983	983	954	954	924	924	938	822	938	729	938	636	938	543
32000	75	1156	785	1156	686	1156	587	1156	489	1156	390	—	—	—	—	—	—
	73	1122	856	1122	757	1122	659	1122	560	1122	462	1122	363	—	—	—	—
	71	1089	928	1089	829	1089	730	1089	632	1089	533	1089	434	—	—	—	—
	67	1030	1030	1025	971	1025	873	1025	774	1025	675	1025	577	1025	478	1025	379
	62	1030	1030	1000	1000	970	970	940	940	947	851	947	752	947	654	947	555

* Rated performance is at sea level. Cooling capacities are gross cooling capacity.

TABLE 13 – COOLING PERFORMANCE DATA* – 85 TON MODEL (cont'd)

115° AIR ON CONDENSER COIL

CFM	ENTERING WB (°F)	CAPACITY (mbh) AT ENTERING DRY BULB (°F)															
		90		86		83		80		77		74		71		68	
		CAP	SHC	CAP	SHC	CAP	SHC	CAP	SHC	CAP	SHC	CAP	SHC	CAP	SHC	CAP	SHC
16000	75	982	542	982	490	982	438	982	385	982	333	—	—	—	—	—	—
	73	951	582	951	530	951	477	951	425	951	373	951	320	—	—	—	—
	71	920	621	920	569	920	516	920	464	920	412	920	359	—	—	—	—
	67	859	698	859	645	859	593	859	541	859	488	859	436	859	384	859	331
	62	791	791	785	738	785	685	785	633	785	581	785	528	785	476	785	424
18000	75	1004	572	1004	514	1004	455	1004	397	1004	339	—	—	—	—	—	—
	73	974	616	974	558	974	499	974	441	974	382	974	324	—	—	—	—
	71	943	660	943	601	943	543	943	484	943	426	943	368	—	—	—	—
	67	883	745	883	687	883	629	883	570	883	512	883	453	883	395	883	337
	62	827	827	804	804	809	733	809	674	809	616	809	557	809	499	809	441
20000	75	1023	601	1023	537	1023	472	1023	408	1023	344	—	—	—	—	—	—
	73	992	649	992	585	992	520	992	456	992	392	992	327	—	—	—	—
	71	962	697	962	633	962	568	962	504	962	440	962	375	—	—	—	—
	67	902	792	902	727	902	663	902	598	902	534	902	470	902	405	902	341
	62	859	859	834	834	829	778	829	714	829	649	829	585	829	521	829	456
22000	75	1039	630	1039	559	1039	489	1039	419	1039	348	—	—	—	—	—	—
	73	1008	682	1008	611	1008	541	1008	471	1008	401	1008	330	—	—	—	—
	71	978	734	978	663	978	593	978	523	978	453	978	382	—	—	—	—
	67	918	837	918	766	918	696	918	626	918	556	918	485	918	415	918	345
	62	887	887	861	861	836	836	846	752	846	682	846	611	846	541	846	471
24000	75	1052	657	1052	581	1052	505	1052	429	1052	353	—	—	—	—	—	—
	73	1022	714	1022	637	1022	561	1022	485	1022	409	1022	333	—	—	—	—
	71	991	770	991	693	991	617	991	541	991	465	991	389	—	—	—	—
	67	932	881	932	805	932	729	932	653	932	576	932	500	932	424	932	348
	62	911	911	885	885	859	859	860	789	860	713	860	637	860	561	860	485
26000	75	1064	685	1064	603	1064	521	1064	439	1064	357	—	—	—	—	—	—
	73	1033	745	1033	663	1033	581	1033	499	1033	418	1033	336	—	—	—	—
	71	1003	805	1003	723	1003	641	1003	559	1003	477	1003	396	—	—	—	—
	67	933	933	944	842	944	760	944	679	944	597	944	515	944	433	944	351
	62	933	933	906	906	880	880	872	825	872	744	872	662	872	580	872	498
28000	75	1074	712	1074	624	1074	537	1074	449	1074	362	—	—	—	—	—	—
	73	1043	776	1043	688	1043	601	1043	513	1043	426	1043	338	—	—	—	—
	71	1013	840	1013	752	1013	665	1013	577	1013	489	1013	402	—	—	—	—
	67	953	953	954	879	954	792	954	704	954	617	954	529	954	442	954	354
	62	953	953	925	925	898	898	871	871	882	773	882	686	882	598	882	511
30000	75	1083	738	1083	645	1083	552	1083	459	1083	366	—	—	—	—	—	—
	73	1052	806	1052	713	1052	620	1052	527	1052	434	1052	340	—	—	—	—
	71	1022	874	1022	781	1022	687	1022	594	1022	501	1022	408	—	—	—	—
	67	970	970	942	942	963	822	963	729	963	636	963	543	963	450	963	357
	62	970	970	942	942	915	915	887	887	891	803	891	710	891	616	891	523
32000	75	1091	764	1091	666	1091	567	1091	468	1091	370	—	—	—	—	—	—
	73	1060	836	1060	737	1060	639	1060	540	1060	441	1060	343	—	—	—	—
	71	1030	907	1030	809	1030	710	1030	611	1030	513	1030	414	—	—	—	—
	67	986	986	958	958	970	852	970	754	970	655	970	556	970	458	970	359
	62	986	986	958	958	929	929	901	901	899	831	899	733	899	634	899	535

* Rated performance is at sea level. Cooling capacities are gross cooling capacity.

Cooling Performance Data – 90 Ton Model

TABLE 14 – COOLING PERFORMANCE DATA* – 90 TON MODEL

85° AIR ON CONDENSER COIL

CFM	ENTERING WB (°F)	CAPACITY (mbh) AT ENTERING DRY BULB (°F)															
		90		86		83		80		77		74		71		68	
		CAP	SHC	CAP	SHC	CAP	SHC	CAP	SHC	CAP	SHC	CAP	SHC	CAP	SHC	CAP	SHC
20000	75	1239	674	1239	611	1239	547	1239	483	1239	420	—	—	—	—	—	—
	73	1196	721	1196	658	1196	594	1196	530	1196	467	1196	403	—	—	—	—
	71	1154	768	1154	704	1154	640	1154	577	1154	513	1154	449	—	—	—	—
	67	1071	858	1071	795	1071	731	1071	667	1071	603	1071	540	1071	476	1071	412
	62	—	—	—	965	910	969	839	969	775	969	712	969	648	969	584	969
22000	75	1265	704	1265	634	1265	565	1265	495	1265	426	—	—	—	—	—	—
	73	1223	755	1223	686	1223	616	1223	547	1223	477	1223	408	—	—	—	—
	71	1181	806	1181	736	1181	667	1181	597	1181	528	1181	458	—	—	—	—
	67	1098	905	1098	836	1098	766	1098	697	1098	627	1098	558	1098	488	1098	419
	62	1010	1010	995	956	997	886	997	816	997	747	997	677	997	608	997	539
24000	75	1288	732	1288	657	1288	582	1288	507	1288	432	—	—	—	—	—	—
	73	1245	788	1245	713	1245	637	1245	562	1245	487	1245	412	—	—	—	—
	71	1203	843	1203	767	1203	692	1203	617	1203	542	1203	467	—	—	—	—
	67	1121	951	1121	875	1121	800	1121	725	1121	650	1121	575	1121	500	1121	425
	62	1043	1043	1013	1013	1020	931	1020	856	1020	780	1020	705	1020	630	1020	555
26000	75	1307	760	1307	679	1307	599	1307	518	1307	437	—	—	—	—	—	—
	73	1265	819	1265	739	1265	658	1265	577	1265	496	1265	416	—	—	—	—
	71	1223	878	1223	798	1223	717	1223	636	1223	555	1223	475	—	—	—	—
	67	1141	995	1141	914	1141	833	1141	752	1141	672	1141	591	1141	510	1141	429
	62	1073	1073	1041	1041	1035	978	1040	894	1040	813	1040	732	1040	651	1040	570
28000	75	1323	787	1323	701	1323	614	1323	528	1323	442	—	—	—	—	—	—
	73	1281	850	1281	764	1281	678	1281	591	1281	505	1281	419	—	—	—	—
	71	1240	913	1240	827	1240	741	1240	654	1240	568	1240	482	—	—	—	—
	67	1158	1038	1158	951	1158	865	1158	779	1158	692	1158	606	1158	520	1158	434
	62	1099	1099	1067	1067	1055	1014	1058	930	1058	844	1058	758	1058	671	1058	585
30000	75	1338	813	1338	722	1338	630	1338	538	1338	446	—	—	—	—	—	—
	73	1296	881	1296	789	1296	697	1296	605	1296	514	1296	422	—	—	—	—
	71	1254	947	1254	856	1254	764	1254	672	1254	580	1254	489	—	—	—	—
	67	1163	1084	1173	988	1173	896	1173	804	1173	713	1173	621	1173	529	1173	437
	62	1123	1123	1091	1091	1058	1058	1073	966	1073	874	1073	782	1073	690	1073	599
32000	75	1350	839	1350	742	1350	645	1350	548	1350	451	—	—	—	—	—	—
	73	1308	910	1308	813	1308	716	1308	619	1308	522	1308	425	—	—	—	—
	71	1267	981	1267	884	1267	787	1267	689	1267	592	1267	495	—	—	—	—
	67	1179	1118	1186	1024	1186	926	1186	829	1186	732	1186	635	1186	538	1186	441
	62	1145	1145	1112	1112	1078	1078	1078	1006	1086	903	1086	806	1086	709	1086	612
34000	75	1361	865	1361	762	1361	660	1361	557	1361	455	—	—	—	—	—	—
	73	1319	939	1319	837	1319	734	1319	632	1319	529	1319	427	—	—	—	—
	71	1278	1014	1278	911	1278	809	1278	706	1278	604	1278	501	—	—	—	—
	67	1193	1151	1197	1059	1197	956	1197	854	1197	751	1197	649	1197	546	1197	444
	62	1165	1165	1131	1131	1097	1097	1092	1034	1098	932	1098	829	1098	727	1098	624
36000	75	1371	890	1371	782	1371	674	1371	567	1371	459	—	—	—	—	—	—
	73	1329	968	1329	860	1329	753	1329	645	1329	537	1329	429	—	—	—	—
	71	1288	1046	1288	938	1288	830	1288	723	1288	615	1288	507	—	—	—	—
	67	1182	1182	1207	1093	1207	985	1207	877	1207	770	1207	662	1207	554	1207	446
	62	1182	1182	1148	1148	1113	1113	1104	1061	1108	960	1108	852	1108	744	1108	636

* Rated performance is at sea level. Cooling capacities are gross cooling capacity.

TABLE 14 – COOLING PERFORMANCE DATA* – 90 TON MODEL (cont'd)

95° AIR ON CONDENSER COIL

CFM	ENTERING WB (°F)	CAPACITY (mbh) AT ENTERING DRY BULB (°F)															
		90		86		83		80		77		74		71		68	
		CAP	SHC	CAP	SHC	CAP	SHC	CAP	SHC	CAP	SHC	CAP	SHC	CAP	SHC	CAP	SHC
20000	75	1194	658	1194	595	1194	531	1194	467	1194	403	—	—	—	—	—	—
	73	1154	705	1154	642	1154	578	1154	514	1154	450	1154	387	—	—	—	—
	71	1114	752	1114	688	1114	624	1114	561	1114	497	1114	433	—	—	—	—
	67	1035	843	1035	779	1035	715	1035	652	1035	588	1035	524	1035	461	1035	397
	62	948	948	937	893	939	825	939	761	939	697	939	634	939	570	939	506
22000	75	1218	687	1218	618	1218	548	1218	479	1218	409	—	—	—	—	—	—
	73	1178	739	1178	669	1178	600	1178	530	1178	461	1178	391	—	—	—	—
	71	1139	789	1139	720	1139	650	1139	581	1139	512	1139	442	—	—	—	—
	67	1060	889	1060	820	1060	750	1060	681	1060	611	1060	542	1060	472	1060	403
	62	983	983	954	954	964	871	964	801	964	732	964	662	964	593	964	523
24000	75	1239	716	1239	640	1239	565	1239	490	1239	415	—	—	—	—	—	—
	73	1199	771	1199	696	1199	621	1199	545	1199	470	1199	395	—	—	—	—
	71	1159	826	1159	751	1159	676	1159	600	1159	525	1159	450	—	—	—	—
	67	1081	934	1081	859	1081	784	1081	709	1081	634	1081	558	1081	483	1081	408
	62	1014	1014	985	985	980	921	986	840	986	765	986	690	986	615	986	539
26000	75	1256	743	1256	662	1256	581	1256	501	1256	420	—	—	—	—	—	—
	73	1217	802	1217	722	1217	641	1217	560	1217	479	1217	399	—	—	—	—
	71	1177	861	1177	781	1177	700	1177	619	1177	538	1177	458	—	—	—	—
	67	1099	978	1099	897	1099	816	1099	736	1099	655	1099	574	1099	493	1099	413
	62	1042	1042	1012	1012	1001	958	1004	877	1004	797	1004	716	1004	635	1004	554
28000	75	1272	770	1272	684	1272	597	1272	511	1272	425	—	—	—	—	—	—
	73	1232	833	1232	747	1232	660	1232	574	1232	488	1232	402	—	—	—	—
	71	1192	896	1192	810	1192	723	1192	637	1192	551	1192	465	—	—	—	—
	67	1106	1027	1115	934	1115	848	1115	762	1115	675	1115	589	1115	503	1115	416
	62	1068	1068	1036	1036	1005	1005	1020	914	1020	827	1020	741	1020	655	1020	568
30000	75	1285	796	1285	704	1285	613	1285	521	1285	429	—	—	—	—	—	—
	73	1245	863	1245	771	1245	680	1245	588	1245	496	1245	404	—	—	—	—
	71	1206	930	1206	838	1206	746	1206	655	1206	563	1206	471	—	—	—	—
	67	1122	1062	1128	970	1128	879	1128	787	1128	695	1128	603	1128	512	1128	420
	62	1090	1090	1058	1058	1027	1027	1026	956	1034	857	1034	765	1034	674	1034	582
32000	75	1296	822	1296	725	1296	628	1296	530	1296	433	—	—	—	—	—	—
	73	1256	893	1256	796	1256	698	1256	601	1256	504	1256	407	—	—	—	—
	71	1217	963	1217	866	1217	769	1217	672	1217	575	1217	477	—	—	—	—
	67	1137	1095	1140	1006	1140	909	1140	812	1140	714	1140	617	1140	520	1140	423
	62	1111	1111	1078	1078	1046	1046	1040	984	1046	886	1046	789	1046	692	1046	595
34000	75	1306	847	1306	745	1306	642	1306	540	1306	437	—	—	—	—	—	—
	73	1266	922	1266	819	1266	717	1266	614	1266	512	1266	409	—	—	—	—
	71	1227	996	1227	893	1227	791	1227	688	1227	586	1227	483	—	—	—	—
	67	1129	1129	1150	1041	1150	938	1150	836	1150	733	1150	631	1150	528	1150	426
	62	1129	1129	1096	1096	1063	1063	1053	1012	1057	914	1057	812	1057	709	1057	607
36000	75	1315	872	1315	765	1315	657	1315	549	1315	441	—	—	—	—	—	—
	73	1275	950	1275	843	1275	735	1275	627	1275	519	1275	412	—	—	—	—
	71	1236	1028	1236	920	1236	813	1236	705	1236	597	1236	489	—	—	—	—
	67	1145	1145	1150	1076	1159	967	1159	859	1159	752	1159	644	1159	536	1159	428
	62	1145	1145	1112	1112	1079	1079	1045	1045	1066	942	1066	834	1066	727	1066	619

* Rated performance is at sea level. Cooling capacities are gross cooling capacity.

Cooling Performance Data – 90 Ton Model (cont'd.)

TABLE 14 – COOLING PERFORMANCE DATA* – 90 TON MODEL (cont'd)

105° AIR ON CONDENSER COIL

CFM	ENTERING WB (°F)	CAPACITY (mbh) AT ENTERING DRY BULB (°F)															
		90		86		83		80		77		74		71		68	
		CAP	SHC	CAP	SHC	CAP	SHC	CAP	SHC	CAP	SHC	CAP	SHC	CAP	SHC	CAP	SHC
20000	75	1146	641	1146	577	1146	514	1146	450	1146	386	—	—	—	—	—	—
	73	1108	688	1108	624	1108	561	1108	497	1108	433	1108	370	—	—	—	—
	71	1070	735	1070	671	1070	607	1070	544	1070	480	1070	416	—	—	—	—
	67	996	826	996	762	996	699	996	635	996	571	996	508	996	444	996	380
	62	920	920	905	873	906	809	906	745	906	682	906	618	906	554	906	490
22000	75	1168	670	1168	600	1168	531	1168	461	1168	392	—	—	—	—	—	—
	73	1130	721	1130	651	1130	582	1130	513	1130	443	1130	374	—	—	—	—
	71	1093	772	1093	702	1093	633	1093	563	1093	494	1093	424	—	—	—	—
	67	1019	872	1019	803	1019	733	1019	664	1019	594	1019	525	1019	455	1019	386
	62	953	953	925	925	922	862	929	785	929	715	929	646	929	576	929	507
24000	75	1187	698	1187	623	1187	547	1187	472	1187	397	—	—	—	—	—	—
	73	1149	753	1149	678	1149	603	1149	527	1149	452	1149	377	—	—	—	—
	71	1111	808	1111	733	1111	658	1111	582	1111	507	1111	432	—	—	—	—
	67	1038	916	1038	841	1038	766	1038	691	1038	616	1038	541	1038	465	1038	390
	62	983	983	954	954	945	900	948	823	948	748	948	673	948	597	948	522
26000	75	1202	725	1202	644	1202	563	1202	483	1202	402	—	—	—	—	—	—
	73	1165	784	1165	703	1165	623	1165	542	1165	461	1165	380	—	—	—	—
	71	1127	843	1127	762	1127	682	1127	601	1127	520	1127	439	—	—	—	—
	67	1054	960	1054	879	1054	798	1054	717	1054	637	1054	556	1054	475	1054	394
	62	1009	1009	980	980	950	950	965	860	965	779	965	698	965	617	965	537
28000	75	1216	752	1216	665	1216	579	1216	493	1216	406	—	—	—	—	—	—
	73	1178	815	1178	728	1178	642	1178	556	1178	470	1178	383	—	—	—	—
	71	1141	878	1141	791	1141	705	1141	619	1141	532	1141	446	—	—	—	—
	67	1063	1003	1068	916	1068	830	1068	743	1068	657	1068	571	1068	484	1068	398
	62	1033	1033	1002	1002	972	972	979	896	979	809	979	723	979	637	979	550
30000	75	1228	778	1228	686	1228	594	1228	503	1228	411	—	—	—	—	—	—
	73	1190	845	1190	753	1190	661	1190	569	1190	478	1190	386	—	—	—	—
	71	1153	911	1153	820	1153	728	1153	636	1153	544	1153	453	—	—	—	—
	67	1078	1037	1080	952	1080	860	1080	768	1080	677	1080	585	1080	493	1080	401
	62	1054	1054	1023	1023	992	992	987	933	992	839	992	747	992	655	992	563
32000	75	1238	804	1238	706	1238	609	1238	512	1238	415	—	—	—	—	—	—
	73	1201	874	1201	777	1201	680	1201	583	1201	486	1201	388	—	—	—	—
	71	1164	945	1164	847	1164	750	1164	653	1164	556	1164	459	—	—	—	—
	67	1073	1073	1091	987	1091	890	1091	793	1091	696	1091	598	1091	501	1091	404
	62	1073	1073	1041	1041	1010	1010	1000	961	1003	867	1003	770	1003	673	1003	576
34000	75	1247	829	1247	726	1247	624	1247	521	1247	419	—	—	—	—	—	—
	73	1210	903	1210	801	1210	698	1210	596	1210	493	1210	391	—	—	—	—
	71	1173	977	1173	875	1173	772	1173	670	1173	567	1173	465	—	—	—	—
	67	1090	1090	1093	1023	1100	919	1100	817	1100	714	1100	612	1100	509	1100	407
	62	1090	1090	1058	1058	1026	1026	994	994	1012	896	1012	793	1012	691	1012	588
36000	75	1255	854	1255	746	1255	638	1255	531	1255	423	—	—	—	—	—	—
	73	1218	932	1218	824	1218	716	1218	608	1218	501	1218	393	—	—	—	—
	71	1181	1009	1181	901	1181	794	1181	686	1181	578	1181	470	—	—	—	—
	67	1105	1105	1103	1051	1108	948	1108	840	1108	733	1108	625	1108	517	1108	409
	62	1105	1105	1073	1073	1041	1041	1009	1009	1020	923	1020	815	1020	708	1020	600

* Rated performance is at sea level. Cooling capacities are gross cooling capacity.

TABLE 14 – COOLING PERFORMANCE DATA* – 90 TON MODEL (cont'd)

115° AIR ON CONDENSER COIL

CFM	ENTERING WB (°F)	CAPACITY (mbh) AT ENTERING DRY BULB (°F)															
		90		86		83		80		77		74		71		68	
		CAP	SHC	CAP	SHC	CAP	SHC	CAP	SHC	CAP	SHC	CAP	SHC	CAP	SHC	CAP	SHC
20000	75	1094	623	1094	559	1094	495	1094	431	1094	368	—	—	—	—	—	—
	73	1058	670	1058	606	1058	542	1058	479	1058	415	1058	351	—	—	—	—
	71	1023	716	1023	653	1023	589	1023	525	1023	461	1023	398	—	—	—	—
	67	953	808	953	744	953	681	953	617	953	553	953	490	953	426	953	362
	62	889	889	863	863	868	791	868	728	868	664	868	600	868	537	868	473
22000	75	1114	651	1114	582	1114	512	1114	443	1114	373	—	—	—	—	—	—
	73	1078	702	1078	633	1078	563	1078	494	1078	424	1078	355	—	—	—	—
	71	1043	753	1043	684	1043	614	1043	545	1043	475	1043	406	—	—	—	—
	67	973	853	973	784	973	714	973	645	973	575	973	506	973	436	973	367
	62	920	920	893	893	885	840	889	767	889	697	889	628	889	558	889	489
24000	75	1130	679	1130	604	1130	528	1130	453	1130	378	—	—	—	—	—	—
	73	1095	734	1095	659	1095	584	1095	508	1095	433	1095	358	—	—	—	—
	71	1060	789	1060	714	1060	639	1060	563	1060	488	1060	413	—	—	—	—
	67	991	897	991	822	991	747	991	672	991	597	991	522	991	446	991	371
	62	948	948	920	920	892	892	906	804	906	729	906	654	906	579	906	504
26000	75	1144	706	1144	625	1144	544	1144	464	1144	383	—	—	—	—	—	—
	73	1109	765	1109	684	1109	603	1109	523	1109	442	1109	361	—	—	—	—
	71	1074	824	1074	743	1074	662	1074	582	1074	501	1074	420	—	—	—	—
	67	1000	942	1005	860	1005	779	1005	698	1005	617	1005	537	1005	456	1005	375
	62	972	972	944	944	915	915	921	841	921	760	921	679	921	598	921	518
28000	75	1157	732	1157	646	1157	560	1157	474	1157	387	—	—	—	—	—	—
	73	1121	795	1121	709	1121	623	1121	537	1121	450	1121	364	—	—	—	—
	71	1086	858	1086	772	1086	685	1086	599	1086	513	1086	427	—	—	—	—
	67	1016	977	1018	896	1018	810	1018	724	1018	637	1018	551	1018	465	1018	378
	62	994	994	965	965	936	936	930	879	934	790	934	704	934	617	934	531
30000	75	—	—	—	—	—	—	—	—	—	—	—	—	—	—	—	—
	73	1132	825	1132	734	1132	642	1132	550	1132	458	1132	366	—	—	—	—
	71	1097	892	1097	800	1097	708	1097	616	1097	525	1097	433	—	—	—	—
	67	1014	1014	1029	932	1029	840	1029	748	1029	657	1029	565	1029	473	1029	381
	62	1014	1014	984	984	954	954	943	907	946	819	946	727	946	635	946	544
32000	75	—	—	—	—	—	—	—	—	—	—	—	—	—	—	—	—
	73	1141	855	1141	757	1141	660	1141	563	1141	466	1141	369	—	—	—	—
	71	1106	925	1106	828	1106	730	1106	633	1106	536	1106	439	—	—	—	—
	67	1032	1032	1032	968	1038	870	1038	773	1038	676	1038	578	1038	481	1038	384
	62	1032	1032	1001	1001	971	971	941	941	955	847	955	750	955	653	955	556
34000	75	—	—	—	—	—	—	—	—	—	—	—	—	—	—	—	—
	73	1149	884	1149	781	1149	679	1149	576	1149	474	1149	371	—	—	—	—
	71	1115	957	1115	855	1115	752	1115	650	1115	547	1115	445	—	—	—	—
	67	1047	1047	1043	996	1046	899	1046	797	1046	694	1046	592	1046	489	1046	387
	62	1047	1047	1017	1017	986	986	955	955	964	875	964	773	964	670	964	568
36000	75	—	—	—	—	—	—	—	—	—	—	—	—	—	—	—	—
	73	1157	912	1157	804	1157	696	1157	589	1157	481	1157	373	—	—	—	—
	71	1122	989	1122	882	1122	774	1122	666	1122	558	1122	451	—	—	—	—
	67	1062	1062	1031	1031	1054	928	1054	820	1054	712	1054	605	1054	497	1054	389
	62	1062	1062	1031	1031	1000	1000	968	968	965	905	971	795	971	687	971	579

* Rated performance is at sea level. Cooling capacities are gross cooling capacity.

Cooling Performance Data – 95 Ton Model

TABLE 15 – COOLING PERFORMANCE DATA* – 95 TON MODEL

85° AIR ON CONDENSER COIL

CFM	ENTERING WB (°F)	CAPACITY (mbh) AT ENTERING DRY BULB (°F)															
		90		86		83		80		77		74		71		68	
		CAP	SHC	CAP	SHC	CAP	SHC	CAP	SHC	CAP	SHC	CAP	SHC	CAP	SHC	CAP	SHC
20000	75	1282	698	1282	632	1282	567	1282	501	1282	436	—	—	—	—	—	—
	73	1239	747	1239	681	1239	615	1239	550	1239	484	1239	419	—	—	—	—
	71	1196	795	1196	729	1196	664	1196	598	1196	532	1196	467	—	—	—	—
	67	1111	889	1111	823	1111	758	1111	692	1111	626	1111	561	1111	495	1111	430
	62	1010	1010	1004	944	1009	870	1009	804	1009	739	1009	673	1009	608	1009	542
22000	75	1310	728	1310	657	1310	585	1310	514	1310	442	—	—	—	—	—	—
	73	1266	782	1266	710	1266	638	1266	567	1266	495	1266	423	—	—	—	—
	71	1224	834	1224	763	1224	691	1224	619	1224	548	1224	476	—	—	—	—
	67	1140	938	1140	866	1140	794	1140	723	1140	651	1140	579	1140	508	1140	436
	62	1049	1049	1036	992	1037	919	1037	847	1037	775	1037	704	1037	632	1037	560
24000	75	1333	758	1333	680	1333	603	1333	525	1333	448	—	—	—	—	—	—
	73	1290	815	1290	738	1290	660	1290	583	1290	505	1290	428	—	—	—	—
	71	1247	872	1247	795	1247	717	1247	640	1247	562	1247	485	—	—	—	—
	67	1163	985	1163	907	1163	830	1163	752	1163	674	1163	597	1163	519	1163	442
	62	1084	1084	1053	1053	1061	965	1061	888	1061	810	1061	733	1061	655	1061	577
26000	75	1352	787	1352	703	1352	620	1352	536	1352	453	—	—	—	—	—	—
	73	1310	848	1310	765	1310	682	1310	598	1310	515	1310	431	—	—	—	—
	71	1267	910	1267	826	1267	743	1267	659	1267	576	1267	493	—	—	—	—
	67	1184	1030	1184	947	1184	864	1184	780	1184	697	1184	613	1184	530	1184	447
	62	1116	1116	1083	1083	1077	1015	1082	927	1082	844	1082	760	1082	677	1082	593
28000	75	1369	815	1369	726	1369	636	1369	547	1369	458	—	—	—	—	—	—
	73	1327	880	1327	791	1327	702	1327	613	1327	524	1327	435	—	—	—	—
	71	1285	946	1285	857	1285	767	1285	678	1285	589	1285	500	—	—	—	—
	67	1201	1075	1201	986	1201	897	1201	808	1201	718	1201	629	1201	540	1201	451
	62	1144	1144	1111	1111	1098	1053	1100	965	1100	876	1100	787	1100	698	1100	608
30000	75	1384	842	1384	747	1384	652	1384	558	1384	463	—	—	—	—	—	—
	73	1342	912	1342	817	1342	722	1342	627	1342	532	1342	438	—	—	—	—
	71	1300	981	1300	886	1300	792	1300	697	1300	602	1300	507	—	—	—	—
	67	1208	1125	1217	1024	1217	929	1217	834	1217	739	1217	644	1217	550	1217	455
	62	1169	1169	1135	1135	1101	1101	1116	1002	1116	907	1116	812	1116	717	1116	623
32000	75	1397	869	1397	769	1397	668	1397	568	1397	467	—	—	—	—	—	—
	73	1355	943	1355	842	1355	742	1355	641	1355	541	1355	440	—	—	—	—
	71	1313	1016	1313	916	1313	815	1313	715	1313	614	1313	514	—	—	—	—
	67	1225	1160	1230	1061	1230	961	1230	860	1230	760	1230	659	1230	559	1230	458
	62	1192	1192	1158	1158	1123	1123	1122	1045	1129	938	1129	837	1129	737	1129	636
34000	75	1408	896	1408	790	1408	684	1408	578	1408	471	0	0	0	0	0	0
	73	1366	973	1366	867	1366	761	1366	655	1366	549	1366	443	0	0	0	0
	71	1324	1050	1324	944	1324	838	1324	732	1324	626	1324	520	0	0	0	0
	67	1239	1195	1242	1098	1242	991	1242	885	1242	779	1242	673	1242	567	1242	461
	62	1213	1213	1178	1178	1142	1142	1136	1074	1141	967	1141	861	1141	755	1141	649
36000	75	1418	922	1418	810	1418	699	1418	587	1418	476	—	—	—	—	—	—
	73	1376	1003	1376	892	1376	780	1376	668	1376	557	1376	445	—	—	—	—
	71	1334	1084	1334	973	1334	861	1334	749	1334	638	1334	526	—	—	—	—
	67	1232	1232	1252	1133	1252	1022	1252	910	1252	799	1252	687	1252	575	1252	464
	62	1232	1232	1196	1196	1160	1160	1149	1103	1152	997	1152	885	1152	773	1152	662

* Rated performance is at sea level. Cooling capacities are gross cooling capacity.

TABLE 15 – COOLING PERFORMANCE DATA* – 95 TON MODEL (cont'd)

95° AIR ON CONDENSER COIL

CFM	ENTERING WB (°F)	CAPACITY (mbh) AT ENTERING DRY BULB (°F)															
		90		86		83		80		77		74		71		68	
		CAP	SHC	CAP	SHC	CAP	SHC	CAP	SHC	CAP	SHC	CAP	SHC	CAP	SHC	CAP	SHC
20000	75	1235	681	1235	615	1235	550	1235	484	1235	418	—	—	—	—	—	—
	73	1194	729	1194	664	1194	598	1194	533	1194	467	1194	401	—	—	—	—
	71	1154	778	1154	712	1154	647	1154	581	1154	515	1154	450	—	—	—	—
	67	1074	872	1074	807	1074	741	1074	675	1074	610	1074	544	1074	479	1074	413
	62	984	984	973	925	976	854	976	789	976	723	976	658	976	592	976	526
22000	75	1260	711	1260	639	1260	568	1260	496	1260	424	—	—	—	—	—	—
	73	1219	764	1219	692	1219	621	1219	549	1219	477	1219	406	—	—	—	—
	71	1179	817	1179	745	1179	673	1179	602	1179	530	1179	459	—	—	—	—
	67	1099	920	1099	849	1099	777	1099	705	1099	634	1099	562	1099	491	1099	419
	62	1021	1021	991	991	1002	902	1002	831	1002	759	1002	687	1002	616	1002	544
24000	75	1281	740	1281	662	1281	585	1281	507	1281	430	—	—	—	—	—	—
	73	1241	797	1241	720	1241	642	1241	565	1241	487	1241	410	—	—	—	—
	71	1200	855	1200	777	1200	699	1200	622	1200	544	1200	467	—	—	—	—
	67	1121	967	1121	889	1121	812	1121	734	1121	657	1121	579	1121	502	1121	424
	62	1054	1054	1023	1023	1019	955	1024	871	1024	793	1024	716	1024	638	1024	561
26000	75	1299	769	1299	685	1299	602	1299	518	1299	435	—	—	—	—	—	—
	73	1259	830	1259	747	1259	663	1259	580	1259	497	1259	413	—	—	—	—
	71	1219	891	1219	808	1219	725	1219	641	1219	558	1219	474	—	—	—	—
	67	1140	1012	1140	929	1140	846	1140	762	1140	679	1140	595	1140	512	1140	429
	62	1084	1084	1052	1052	1041	994	1043	910	1043	826	1043	743	1043	659	1043	576
28000	75	1315	796	1315	707	1315	618	1315	529	1315	440	—	—	—	—	—	—
	73	1274	862	1274	773	1274	684	1274	595	1274	505	1274	416	—	—	—	—
	71	1234	927	1234	838	1234	749	1234	660	1234	571	1234	482	—	—	—	—
	67	1148	1065	1156	968	1156	878	1156	789	1156	700	1156	611	1156	522	1156	433
	62	1110	1110	1078	1078	1045	1045	1060	947	1060	858	1060	769	1060	680	1060	590
30000	75	1328	824	1328	729	1328	634	1328	539	1328	444	—	—	—	—	—	—
	73	1288	893	1288	799	1288	704	1288	609	1288	514	1288	419	—	—	—	—
	71	1248	963	1248	868	1248	773	1248	678	1248	583	1248	488	—	—	—	—
	67	1165	1101	1170	1005	1170	910	1170	816	1170	721	1170	626	1170	531	1170	436
	62	1134	1134	1101	1101	1068	1068	1067	992	1074	889	1074	794	1074	699	1074	604
32000	75	1340	851	1340	750	1340	650	1340	549	1340	449	—	—	—	—	—	—
	73	1300	924	1300	824	1300	723	1300	623	1300	522	1300	422	—	—	—	—
	71	1260	997	1260	897	1260	796	1260	696	1260	595	1260	495	—	—	—	—
	67	1180	1136	1182	1042	1182	942	1182	841	1182	741	1182	640	1182	540	1182	439
	62	1156	1156	1122	1122	1088	1088	1081	1022	1087	919	1087	819	1087	718	1087	618
34000	75	1350	877	1350	771	1350	665	1350	559	1350	453	—	—	—	—	—	—
	73	1310	955	1310	848	1310	742	1310	636	1310	530	1310	424	—	—	—	—
	71	1270	1032	1270	926	1270	819	1270	713	1270	607	1270	501	—	—	—	—
	67	1175	1175	1192	1079	1192	973	1192	866	1192	760	1192	654	1192	548	1192	442
	62	1175	1175	1141	1141	1107	1107	1095	1051	1097	949	1097	843	1097	737	1097	630
36000	75	1359	903	1359	792	1359	680	1359	569	1359	457	—	—	—	—	—	—
	73	1319	984	1319	873	1319	761	1319	650	1319	538	1319	426	—	—	—	—
	71	1279	1065	1279	954	1279	842	1279	730	1279	619	1279	507	—	—	—	—
	67	1193	1193	1194	1117	1201	1003	1201	891	1201	780	1201	668	1201	556	1201	445
	62	1193	1193	1158	1158	1123	1123	1089	1089	1107	978	1107	866	1107	754	1107	643

* Rated performance is at sea level. Cooling capacities are gross cooling capacity.

Cooling Performance Data – 95 Ton Model (cont'd.)

TABLE 15 – COOLING PERFORMANCE DATA* – 95 TON MODEL (cont'd)

105° AIR ON CONDENSER COIL

CFM	ENTERING WB (°F)	CAPACITY (mbh) AT ENTERING DRY BULB (°F)															
		90		86		83		80		77		74		71		68	
		CAP	SHC	CAP	SHC	CAP	SHC	CAP	SHC	CAP	SHC	CAP	SHC	CAP	SHC	CAP	SHC
20000	75	1185	662	1185	597	1185	531	1185	466	1185	400	—	—	—	—	—	—
	73	1146	711	1146	646	1146	580	1146	514	1146	449	1146	383	—	—	—	—
	71	1108	759	1108	694	1108	628	1108	563	1108	497	1108	431	—	—	—	—
	67	1032	854	1032	789	1032	723	1032	658	1032	592	1032	526	1032	461	1032	395
	62	955	955	940	905	940	837	940	772	940	706	940	641	940	575	940	509
22000	75	1207	692	1207	621	1207	549	1207	477	1207	406	—	—	—	—	—	—
	73	1169	745	1169	674	1169	602	1169	530	1169	459	1169	387	—	—	—	—
	71	1130	798	1130	726	1130	655	1130	583	1130	512	1130	440	—	—	—	—
	67	1055	902	1055	830	1055	759	1055	687	1055	615	1055	544	1055	472	1055	401
	62	989	989	960	960	964	884	964	813	964	741	964	670	964	598	964	526
24000	75	1226	721	1226	644	1226	566	1226	488	1226	411	—	—	—	—	—	—
	73	1188	778	1188	701	1188	623	1188	546	1188	468	1188	391	—	—	—	—
	71	1150	835	1150	758	1150	680	1150	603	1150	525	1150	448	—	—	—	—
	67	1075	948	1075	870	1075	793	1075	715	1075	638	1075	560	1075	483	1075	405
	62	1020	1020	991	991	981	933	984	852	984	775	984	697	984	620	984	542
26000	75	1242	749	1242	666	1242	583	1242	499	1242	416	—	—	—	—	—	—
	73	1204	811	1204	728	1204	644	1204	561	1204	477	1204	394	—	—	—	—
	71	1166	872	1166	789	1166	705	1166	622	1166	538	1166	455	—	—	—	—
	67	1092	993	1092	910	1092	826	1092	743	1092	659	1092	576	1092	493	1092	409
	62	1048	1048	1017	1017	987	987	1001	891	1001	807	1001	724	1001	640	1001	557
28000	75	1256	777	1256	688	1256	599	1256	510	1256	421	—	—	—	—	—	—
	73	1218	843	1218	754	1218	664	1218	575	1218	486	1218	397	—	—	—	—
	71	1180	908	1180	819	1180	730	1180	640	1180	551	1180	462	—	—	—	—
	67	1102	1039	1106	948	1106	859	1106	770	1106	680	1106	591	1106	502	1106	413
	62	1073	1073	1042	1042	1010	1010	1016	928	1016	839	1016	750	1016	660	1016	571
30000	75	1268	805	1268	710	1268	615	1268	520	1268	425	—	—	—	—	—	—
	73	1230	874	1230	779	1230	684	1230	589	1230	494	1230	400	—	—	—	—
	71	1193	943	1193	848	1193	753	1193	658	1193	564	1193	469	—	—	—	—
	67	1117	1075	1119	985	1119	891	1119	796	1119	701	1119	606	1119	511	1119	416
	62	1095	1095	1063	1063	1031	1031	1024	967	1029	869	1029	774	1029	680	1029	585
32000	75	1279	831	1279	731	1279	630	1279	530	1279	429	—	—	—	—	—	—
	73	1241	905	1241	804	1241	704	1241	603	1241	503	1241	402	—	—	—	—
	71	1203	978	1203	877	1203	777	1203	676	1203	576	1203	475	—	—	—	—
	67	1116	1116	1130	1022	1130	922	1130	821	1130	721	1130	620	1130	520	1130	419
	62	1116	1116	1083	1083	1050	1050	1038	996	1040	899	1040	799	1040	698	1040	598
34000	75	1289	858	1289	752	1289	646	1289	540	1289	434	—	—	—	—	—	—
	73	1250	935	1250	829	1250	723	1250	617	1250	511	1250	404	—	—	—	—
	71	1213	1012	1213	906	1213	800	1213	693	1213	587	1213	481	—	—	—	—
	67	1134	1134	1133	1061	1139	952	1139	846	1139	740	1139	634	1139	528	1139	422
	62	1134	1134	1101	1101	1068	1068	1034	1034	1050	929	1050	822	1050	716	1050	610
36000	75	1297	884	1297	772	1297	661	1297	549	1297	438	—	—	—	—	—	—
	73	1259	965	1259	853	1259	742	1259	630	1259	518	1259	407	—	—	—	—
	71	1221	1045	1221	934	1221	822	1221	711	1221	599	1221	487	—	—	—	—
	67	1150	1150	1144	1090	1148	982	1148	871	1148	759	1148	648	1148	536	1148	425
	62	1150	1150	1117	1117	1083	1083	1050	1050	1058	957	1058	846	1058	734	1058	622

* Rated performance is at sea level. Cooling capacities are gross cooling capacity.

TABLE 15 – COOLING PERFORMANCE DATA* – 95 TON MODEL (cont'd)

115° AIR ON CONDENSER COIL

CFM	ENTERING WB (°F)	CAPACITY (mbh) AT ENTERING DRY BULB (°F)															
		90		86		83		80		77		74		71		68	
		CAP	SHC	CAP	SHC	CAP	SHC	CAP	SHC	CAP	SHC	CAP	SHC	CAP	SHC	CAP	SHC
20000	75	1130	643	1130	577	1130	512	1130	446	1130	380	—	—	—	—	—	—
	73	1093	692	1093	626	1093	560	1093	495	1093	429	1093	364	—	—	—	—
	71	1057	740	1057	674	1057	609	1057	543	1057	477	1057	412	—	—	—	—
	67	987	835	987	769	987	704	987	638	987	573	987	507	987	441	987	376
	62	922	922	895	895	900	819	900	753	900	687	900	622	900	556	900	491
22000	75	1150	672	1150	601	1150	529	1150	458	1150	386	—	—	—	—	—	—
	73	1114	725	1114	654	1114	582	1114	511	1114	439	1114	367	—	—	—	—
	71	1078	778	1078	706	1078	635	1078	563	1078	492	1078	420	—	—	—	—
	67	1007	882	1007	810	1007	739	1007	667	1007	596	1007	524	1007	452	1007	381
	62	955	955	927	927	918	870	922	793	922	722	922	650	922	579	922	507
24000	75	1167	701	1167	624	1167	546	1167	469	1167	391	—	—	—	—	—	—
	73	1131	758	1131	681	1131	603	1131	526	1131	448	1131	371	—	—	—	—
	71	1095	815	1095	738	1095	660	1095	583	1095	505	1095	427	—	—	—	—
	67	1025	928	1025	850	1025	773	1025	695	1025	618	1025	540	1025	462	1025	385
	62	984	984	955	955	926	926	940	832	940	755	940	677	940	600	940	522
26000	75	1181	729	1181	646	1181	563	1181	479	1181	396	—	—	—	—	—	—
	73	1145	791	1145	707	1145	624	1145	540	1145	457	1145	374	—	—	—	—
	71	1110	852	1110	768	1110	685	1110	601	1110	518	1110	435	—	—	—	—
	67	1036	976	1040	889	1040	806	1040	722	1040	639	1040	555	1040	472	1040	389
	62	1009	1009	980	980	950	950	955	870	955	787	955	703	955	620	955	537
28000	75	—	—	—	—	—	—	—	—	—	—	—	—	—	—	—	—
	73	1158	822	1158	733	1158	644	1158	555	1158	466	1158	376	—	—	—	—
	71	1123	887	1123	798	1123	709	1123	620	1123	531	1123	441	—	—	—	—
	67	1052	1012	1053	927	1053	838	1053	749	1053	660	1053	570	1053	481	1053	392
	62	1032	1032	1002	1002	972	972	964	911	968	818	968	729	968	640	968	550
30000	75	—	—	—	—	—	—	—	—	—	—	—	—	—	—	—	—
	73	1169	853	1169	759	1169	664	1169	569	1169	474	1169	379	—	—	—	—
	71	1134	922	1134	827	1134	733	1134	638	1134	543	1134	448	—	—	—	—
	67	1053	1053	1057	974	1064	870	1064	775	1064	680	1064	585	1064	490	1064	395
	62	1053	1053	1022	1022	991	991	978	940	980	848	980	753	980	659	980	564
32000	75	—	—	—	—	—	—	—	—	—	—	—	—	—	—	—	—
	73	1179	884	1179	784	1179	683	1179	583	1179	482	1179	382	—	—	—	—
	71	1143	957	1143	856	1143	756	1143	655	1143	555	1143	454	—	—	—	—
	67	1072	1072	1070	1003	1074	901	1074	800	1074	700	1074	599	1074	499	1074	398
	62	1072	1072	1040	1040	1009	1009	978	978	990	878	990	777	990	677	990	576
34000	75	—	—	—	—	—	—	—	—	—	—	—	—	—	—	—	—
	73	—	—	—	—	—	—	—	—	—	—	—	—	—	—	—	—
	71	1152	991	1152	885	1152	779	1152	673	1152	567	1152	460	—	—	—	—
	67	1089	1089	1080	1032	1082	931	1082	825	1082	719	1082	613	1082	507	1082	401
	62	1089	1089	1057	1057	1025	1025	993	993	999	907	999	801	999	695	999	589
36000	75	—	—	—	—	—	—	—	—	—	—	—	—	—	—	—	—
	73	—	—	—	—	—	—	—	—	—	—	—	—	—	—	—	—
	71	1159	1024	1159	913	1159	801	1159	690	1159	578	1159	466	—	—	—	—
	67	1104	1104	1072	1072	1090	961	1090	850	1090	738	1090	626	1090	515	1090	403
	62	1104	1104	1072	1072	1039	1039	1007	1007	1001	939	1006	824	1006	712	1006	601

* Rated performance is at sea level. Cooling capacities are gross cooling capacity.

Cooling Performance Data – 105 Ton Model

TABLE 16 – COOLING PERFORMANCE DATA* – 105 TON MODEL

85° AIR ON CONDENSER COIL

CFM	ENTERING WB (°F)	CAPACITY (mbh) AT ENTERING DRY BULB (°F)															
		90		86		83		80		77		74		71		68	
		CAP	SHC	CAP	SHC	CAP	SHC	CAP	SHC	CAP	SHC	CAP	SHC	CAP	SHC	CAP	SHC
20000	75	1326	718	1326	652	1326	586	1326	520	1326	454	—	—	—	—	—	—
	73	1283	768	1283	702	1283	636	1283	570	1283	504	1283	437	—	—	—	—
	71	1241	818	1241	752	1241	686	1241	619	1241	553	1241	487	—	—	—	—
	67	1161	916	1161	850	1161	784	1161	718	1161	652	1161	586	1161	519	1161	453
	62	1049	1049	1067	970	1067	904	1067	838	1067	772	1067	706	1067	639	1067	573
22000	75	1355	750	1355	677	1355	605	1355	533	1355	460	—	—	—	—	—	—
	73	1311	804	1311	732	1311	659	1311	587	1311	515	1311	442	—	—	—	—
	71	1269	858	1269	786	1269	713	1269	641	1269	569	1269	496	—	—	—	—
	67	1187	965	1187	893	1187	821	1187	748	1187	676	1187	603	1187	531	1187	459
24000	62	1088	1088	1092	1024	1092	952	1092	879	1092	807	1092	735	1092	662	1092	590
	75	1381	781	1381	702	1381	624	1381	545	1381	467	—	—	—	—	—	—
	73	1336	839	1336	761	1336	682	1336	604	1336	525	1336	446	—	—	—	—
	71	1293	898	1293	819	1293	740	1293	662	1293	583	1293	505	—	—	—	—
	67	1210	1013	1210	935	1210	856	1210	778	1210	699	1210	620	1210	542	1210	463
26000	62	1124	1124	1093	1093	1114	998	1114	920	1114	841	1114	763	1114	684	1114	606
	75	1403	811	1403	726	1403	642	1403	557	1403	472	—	—	—	—	—	—
	73	1358	874	1358	789	1358	704	1358	620	1358	535	1358	450	—	—	—	—
	71	1314	936	1314	851	1314	767	1314	682	1314	597	1314	513	—	—	—	—
	67	1231	1060	1231	976	1231	891	1231	806	1231	722	1231	637	1231	552	1231	468
28000	62	1157	1157	1124	1124	1133	1044	1133	959	1133	875	1133	790	1133	705	1133	621
	75	1423	841	1423	750	1423	659	1423	569	1423	478	—	—	—	—	—	—
	73	1377	908	1377	817	1377	726	1377	635	1377	545	1377	454	—	—	—	—
	71	1333	974	1333	883	1333	793	1333	702	1333	611	1333	521	—	—	—	—
	67	1248	1107	1248	1016	1248	925	1248	834	1248	744	1248	653	1248	562	1248	472
30000	62	1186	1186	1152	1152	1150	1089	1150	998	1150	907	1150	817	1150	726	1150	635
	75	1440	870	1440	773	1440	677	1440	580	1440	483	—	—	—	—	—	—
	73	1394	941	1394	844	1394	747	1394	651	1394	554	1394	457	—	—	—	—
	71	1349	1011	1349	915	1349	818	1349	721	1349	625	1349	528	—	—	—	—
	67	1264	1152	1264	1055	1264	959	1264	862	1264	765	1264	669	1264	572	1264	475
32000	62	1213	1213	1178	1178	1144	1144	1165	1036	1165	939	1165	843	1165	746	1165	649
	75	1455	899	1455	796	1455	694	1455	591	1455	488	—	—	—	—	—	—
	73	1409	974	1409	871	1409	768	1409	666	1409	563	1409	460	—	—	—	—
	71	1364	1048	1364	946	1364	843	1364	740	1364	638	1364	535	—	—	—	—
	67	1278	1197	1278	1094	1278	992	1278	889	1278	786	1278	684	1278	581	1278	479
34000	62	1237	1237	1202	1202	1166	1166	1178	1073	1178	971	1178	868	1178	765	1178	663
	75	1469	927	1469	819	1469	710	1469	602	1469	493	—	—	—	—	—	—
	73	1422	1006	1422	897	1422	789	1422	680	1422	572	1422	463	—	—	—	—
	71	1377	1084	1377	976	1377	867	1377	759	1377	650	1377	542	—	—	—	—
	67	1259	1259	1290	1133	1290	1024	1290	916	1290	807	1290	699	1290	590	1290	482
36000	62	1259	1259	1223	1223	1187	1187	1190	1110	1190	1001	1190	893	1190	784	1190	676
	75	1481	955	1481	841	1481	727	1481	612	1481	498	—	—	—	—	—	—
	73	1434	1038	1434	923	1434	809	1434	695	1434	580	1434	466	—	—	—	—
	71	1388	1120	1388	1006	1388	891	1388	777	1388	663	1388	549	—	—	—	—
	67	1280	1280	1301	1170	1301	1056	1301	942	1301	827	1301	713	1301	599	1301	484
36000	62	1280	1280	1243	1243	1206	1206	1169	1169	1200	1032	1200	917	1200	803	1200	689

* Rated performance is at sea level. Cooling capacities are gross cooling capacity.

TABLE 16 – COOLING PERFORMANCE DATA* – 105 TON MODEL (cont'd)

95° AIR ON CONDENSER COIL

CFM	ENTERING WB (°F)	CAPACITY (mbh) AT ENTERING DRY BULB (°F)															
		90		86		83		80		77		74		71		68	
		CAP	SHC	CAP	SHC	CAP	SHC	CAP	SHC	CAP	SHC	CAP	SHC	CAP	SHC	CAP	SHC
20000	75	1277	700	1277	634	1277	568	1277	502	1277	435	—	—	—	—	—	—
	73	1236	750	1236	684	1236	617	1236	551	1236	485	1236	419	—	—	—	—
	71	1195	799	1195	733	1195	667	1195	601	1195	535	1195	468	—	—	—	—
	67	1118	897	1118	831	1118	765	1118	699	1118	633	1118	566	1118	500	1118	434
	62	1019	1019	1028	951	1028	885	1028	819	1028	752	1028	686	1028	620	1028	554
22000	75	1305	732	1305	659	1305	587	1305	514	1305	442	—	—	—	—	—	—
	73	1262	785	1262	713	1262	641	1262	568	1262	496	1262	423	—	—	—	—
	71	1221	839	1221	767	1221	694	1221	622	1221	550	1221	477	—	—	—	—
	67	1143	946	1143	874	1143	801	1143	729	1143	656	1143	584	1143	512	1143	439
24000	62	1057	1057	1027	1027	1052	932	1052	860	1052	787	1052	715	1052	643	1052	570
	75	1329	762	1329	684	1329	605	1329	527	1329	448	—	—	—	—	—	—
	73	1286	820	1286	742	1286	663	1286	585	1286	506	1286	428	—	—	—	—
	71	1244	878	1244	800	1244	721	1244	643	1244	564	1244	486	—	—	—	—
	67	1164	994	1164	915	1164	837	1164	758	1164	679	1164	601	1164	522	1164	444
26000	62	1091	1091	1060	1060	1072	978	1072	900	1072	821	1072	743	1072	664	1072	586
	75	1349	793	1349	708	1349	623	1349	539	1349	454	—	—	—	—	—	—
	73	1306	855	1306	770	1306	685	1306	601	1306	516	1306	431	—	—	—	—
	71	1264	917	1264	832	1264	748	1264	663	1264	578	1264	494	—	—	—	—
	67	1183	1041	1183	956	1183	871	1183	787	1183	702	1183	617	1183	533	1183	448
28000	62	1122	1122	1090	1090	1090	1024	1090	939	1090	854	1090	770	1090	685	1090	600
	75	1368	822	1368	732	1368	641	1368	550	1368	459	—	—	—	—	—	—
	73	1324	889	1324	798	1324	707	1324	616	1324	526	1324	435	—	—	—	—
	71	1281	955	1281	864	1281	773	1281	683	1281	592	1281	501	—	—	—	—
	67	1200	1087	1200	996	1200	905	1200	815	1200	724	1200	633	1200	542	1200	452
30000	62	1150	1150	1117	1117	1084	1084	1105	978	1105	887	1105	796	1105	705	1105	615
	75	1384	851	1384	755	1384	658	1384	561	1384	465	—	—	—	—	—	—
	73	1339	922	1339	825	1339	728	1339	632	1339	535	1339	438	—	—	—	—
	71	1296	992	1296	895	1296	799	1296	702	1296	605	1296	509	—	—	—	—
	67	1214	1132	1214	1035	1214	939	1214	842	1214	745	1214	649	1214	552	1214	455
32000	62	1176	1176	1141	1141	1108	1108	1119	1015	1119	919	1119	822	1119	725	1119	629
	75	1398	880	1398	778	1398	675	1398	572	1398	470	—	—	—	—	—	—
	73	1353	954	1353	852	1353	749	1353	647	1353	544	1353	441	—	—	—	—
	71	1310	1029	1310	926	1310	823	1310	721	1310	618	1310	516	—	—	—	—
	67	1199	1199	1227	1074	1227	972	1227	869	1227	766	1227	664	1227	561	1227	458
34000	62	1199	1199	1164	1164	1129	1129	1131	1053	1131	950	1131	847	1131	745	1131	642
	75	1410	908	1410	800	1410	691	1410	583	1410	474	—	—	—	—	—	—
	73	1365	987	1365	878	1365	770	1365	661	1365	553	1365	444	—	—	—	—
	71	1322	1065	1322	956	1322	848	1322	739	1322	631	1322	522	—	—	—	—
	67	1220	1220	1238	1112	1238	1004	1238	895	1238	787	1238	678	1238	570	1238	461
36000	62	1220	1220	1184	1184	1149	1149	1114	1114	1142	981	1142	872	1142	764	1142	655
	75	1421	936	1421	822	1421	708	1421	593	1421	479	—	—	—	—	—	—
	73	1376	1018	1376	904	1376	790	1376	675	1376	561	1376	447	—	—	—	—
	71	1332	1101	1332	986	1332	872	1332	758	1332	643	1332	529	—	—	—	—
	67	1239	1239	1249	1150	1249	1036	1249	922	1249	807	1249	693	1249	579	1249	464
36000	62	1239	1239	1203	1203	1166	1166	1131	1131	1151	1011	1151	896	1151	782	1151	668

* Rated performance is at sea level. Cooling capacities are gross cooling capacity.

Cooling Performance Data – 105 Ton Model (cont'd.)

TABLE 16 – COOLING PERFORMANCE DATA* – 105 TON MODEL

105° AIR ON CONDENSER COIL

CFM	ENTERING WB (°F)	CAPACITY (mbh) AT ENTERING DRY BULB (°F)															
		90		86		83		80		77		74		71		68	
		CAP	SHC	CAP	SHC	CAP	SHC	CAP	SHC	CAP	SHC	CAP	SHC	CAP	SHC	CAP	SHC
20000	75	1226	681	1226	615	1226	549	1226	483	1226	417	—	—	—	—	—	—
	73	1186	731	1186	664	1186	598	1186	532	1186	466	1186	400	—	—	—	—
	71	1147	780	1147	713	1147	647	1147	581	1147	515	1147	449	—	—	—	—
	67	1073	877	1073	811	1073	745	1073	679	1073	612	1073	546	1073	480	1073	414
	62	987	987	986	930	986	864	986	798	986	732	986	666	986	600	986	533
22000	75	1252	713	1252	640	1252	568	1252	495	1252	423	—	—	—	—	—	—
	73	1211	766	1211	694	1211	621	1211	549	1211	477	1211	404	—	—	—	—
	71	1171	820	1171	747	1171	675	1171	602	1171	530	1171	458	—	—	—	—
	67	1096	926	1096	853	1096	781	1096	708	1096	636	1096	564	1096	491	1096	419
24000	62	1023	1023	994	994	1008	911	1008	839	1008	767	1008	694	1008	622	1008	549
	75	1274	743	1274	665	1274	586	1274	508	1274	429	—	—	—	—	—	—
	73	1232	801	1232	722	1232	644	1232	565	1232	487	1232	408	—	—	—	—
	71	1192	859	1192	780	1192	701	1192	623	1192	544	1192	466	—	—	—	—
	67	1116	973	1116	895	1116	816	1116	738	1116	659	1116	580	1116	502	1116	423
26000	62	1056	1056	1025	1025	1026	957	1026	879	1026	800	1026	722	1026	643	1026	565
	75	1293	773	1293	689	1293	604	1293	519	1293	435	—	—	—	—	—	—
	73	1251	835	1251	751	1251	666	1251	581	1251	497	1251	412	—	—	—	—
	71	1211	897	1211	812	1211	728	1211	643	1211	558	1211	474	—	—	—	—
	67	1133	1020	1133	935	1133	851	1133	766	1133	681	1133	597	1133	512	1133	427
28000	62	1085	1085	1053	1053	1022	1022	1043	918	1043	833	1043	749	1043	664	1043	579
	75	1310	803	1310	712	1310	622	1310	531	1310	440	—	—	—	—	—	—
	73	1268	869	1268	778	1268	688	1268	597	1268	506	1268	415	—	—	—	—
	71	1227	935	1227	844	1227	753	1227	663	1227	572	1227	481	—	—	—	—
	67	1148	1066	1148	975	1148	885	1148	794	1148	703	1148	612	1148	522	1148	431
30000	62	1112	1112	1079	1079	1047	1047	1057	956	1057	866	1057	775	1057	684	1057	593
	75	1325	832	1325	735	1325	639	1325	542	1325	445	—	—	—	—	—	—
	73	1282	902	1282	805	1282	709	1282	612	1282	515	1282	419	—	—	—	—
	71	1241	972	1241	875	1241	779	1241	682	1241	585	1241	488	—	—	—	—
	67	1136	1136	1162	1015	1162	918	1162	821	1162	725	1162	628	1162	531	1162	434
32000	62	1136	1136	1102	1102	1069	1069	1070	994	1070	897	1070	801	1070	704	1070	607
	75	1338	861	1338	758	1338	656	1338	553	1338	450	—	—	—	—	—	—
	73	1295	935	1295	832	1295	729	1295	627	1295	524	1295	422	—	—	—	—
	71	1253	1009	1253	906	1253	803	1253	701	1253	598	1253	495	—	—	—	—
	67	1158	1158	1174	1053	1174	951	1174	848	1174	746	1174	643	1174	540	1174	438
34000	62	1158	1158	1123	1123	1089	1089	1056	1056	1081	928	1081	826	1081	723	1081	620
	75	1350	889	1350	781	1350	672	1350	564	1350	455	—	—	—	—	—	—
	73	1306	967	1306	858	1306	750	1306	641	1306	533	1306	424	—	—	—	—
	71	1264	1045	1264	936	1264	828	1264	719	1264	611	1264	502	—	—	—	—
	67	1178	1178	1184	1092	1184	983	1184	875	1184	766	1184	658	1184	549	1184	441
36000	62	1178	1178	1143	1143	1108	1108	1074	1074	1091	959	1091	850	1091	742	1091	633
	75	1360	917	1360	803	1360	688	1360	574	1360	460	—	—	—	—	—	—
	73	1316	999	1316	884	1316	770	1316	656	1316	541	1316	427	—	—	—	—
	71	1274	1080	1274	966	1274	852	1274	737	1274	623	1274	509	—	—	—	—
	67	1196	1196	1193	1129	1193	1015	1193	901	1193	786	1193	672	1193	558	1193	443
62	1196	1196	1160	1160	1125	1125	1090	1090	1100	989	1100	875	1100	760	1100	646	

* Rated performance is at sea level. Cooling capacities are gross cooling capacity.

TABLE 16 – COOLING PERFORMANCE DATA* – 105 TON MODEL (cont'd)

115° AIR ON CONDENSER COIL

CFM	ENTERING WB (°F)	CAPACITY (mbh) AT ENTERING DRY BULB (°F)															
		90		86		83		80		77		74		71		68	
		CAP	SHC	CAP	SHC	CAP	SHC	CAP	SHC	CAP	SHC	CAP	SHC	CAP	SHC	CAP	SHC
20000	75	1173	662	1173	596	1173	530	1173	463	1173	397	—	—	—	—	—	—
	73	1134	711	1134	645	1134	578	1134	512	1134	446	1134	380	—	—	—	—
	71	1096	760	1096	693	1096	627	1096	561	1096	495	1096	429	—	—	—	—
	67	1024	856	1024	790	1024	724	1024	658	1024	592	1024	525	1024	459	1024	393
	62	952	952	925	925	941	843	941	777	941	710	941	644	941	578	941	512
22000	75	1197	693	1197	621	1197	548	1197	476	1197	404	—	—	—	—	—	—
	73	1157	746	1157	674	1157	601	1157	529	1157	457	1157	384	—	—	—	—
	71	1119	799	1119	727	1119	654	1119	582	1119	510	1119	437	—	—	—	—
	67	1046	905	1046	832	1046	760	1046	687	1046	615	1046	543	1046	470	1046	398
	62	987	987	958	958	961	890	961	817	961	745	961	672	961	600	961	528
24000	75	1217	724	1217	645	1217	567	1217	488	1217	409	—	—	—	—	—	—
	73	1177	781	1177	702	1177	624	1177	545	1177	467	1177	388	—	—	—	—
	71	1138	838	1138	760	1138	681	1138	603	1138	524	1138	445	—	—	—	—
	67	1064	952	1064	874	1064	795	1064	716	1064	638	1064	559	1064	481	1064	402
	62	1018	1018	988	988	958	958	978	857	978	778	978	700	978	621	978	543
26000	75	1235	754	1235	669	1235	584	1235	500	1235	415	—	—	—	—	—	—
	73	1194	815	1194	731	1194	646	1194	561	1194	477	1194	392	—	—	—	—
	71	1155	877	1155	792	1155	707	1155	623	1155	538	1155	453	—	—	—	—
	67	1080	999	1080	914	1080	829	1080	745	1080	660	1080	575	1080	491	1080	406
	62	1046	1046	1015	1015	984	984	994	896	994	811	994	726	994	642	994	557
28000	75	1251	783	1251	693	1251	602	1251	511	1251	421	—	—	—	—	—	—
	73	1210	849	1210	758	1210	667	1210	577	1210	486	1210	395	—	—	—	—
	71	1170	914	1170	824	1170	733	1170	642	1170	551	1170	461	—	—	—	—
	67	1071	1071	1094	954	1094	863	1094	773	1094	682	1094	591	1094	500	1094	410
	62	1071	1071	1039	1039	1007	1007	1007	934	1007	843	1007	753	1007	662	1007	571
30000	75	1264	812	1264	716	1264	619	1264	522	1264	426	—	—	—	—	—	—
	73	1223	882	1223	785	1223	689	1223	592	1223	495	1223	398	—	—	—	—
	71	1183	951	1183	855	1183	758	1183	661	1183	565	1183	468	—	—	—	—
	67	1094	1094	1107	993	1107	897	1107	800	1107	703	1107	606	1107	510	1107	413
	62	1094	1094	1061	1061	1028	1028	996	996	1019	875	1019	778	1019	681	1019	585
32000	75	1276	841	1276	738	1276	636	1276	533	1276	431	—	—	—	—	—	—
	73	1235	915	1235	812	1235	709	1235	607	1235	504	1235	401	—	—	—	—
	71	1195	988	1195	885	1195	783	1195	680	1195	577	1195	475	—	—	—	—
	67	1115	1115	1118	1032	1118	929	1118	827	1118	724	1118	621	1118	519	1118	416
	62	1115	1115	1081	1081	1048	1048	1015	1015	1029	906	1029	803	1029	701	1029	598
34000	75	1287	869	1287	761	1287	652	1287	544	1287	435	—	—	—	—	—	—
	73	1245	947	1245	838	1245	730	1245	621	1245	513	1245	404	—	—	—	—
	71	1205	1024	1205	916	1205	807	1205	699	1205	590	1205	482	—	—	—	—
	67	1134	1134	1128	1070	1128	962	1128	853	1128	745	1128	636	1128	528	1128	419
	62	1134	1134	1099	1099	1065	1065	1031	1031	1038	936	1038	828	1038	719	1038	611
36000	75	1297	897	1297	783	1297	668	1297	554	1297	440	—	—	—	—	—	—
	73	1255	978	1255	864	1255	750	1255	635	1255	521	1255	407	—	—	—	—
	71	1214	1060	1214	945	1214	831	1214	717	1214	602	1214	488	—	—	—	—
	67	1151	1151	1116	1116	1136	993	1136	879	1136	765	1136	650	1136	536	1136	422
	62	1151	1151	1116	1116	1081	1081	1046	1046	1046	966	1046	852	1046	738	1046	624

* Rated performance is at sea level. Cooling capacities are gross cooling capacity.

Cooling Performance Data – 106 Ton Model

TABLE 17 – COOLING PERFORMANCE DATA* – 106 TON MODEL

85° AIR ON CONDENSER COIL

CFM	ENTERING WB (°F)	CAPACITY (mbh) AT ENTERING DRY BULB (°F)															
		90		86		83		80		77		74		71		68	
		TMBH	SMBH	TMBH	SMBH	TMBH	SMBH	TMBH	SMBH	TMBH	SMBH	TMBH	SMBH	TMBH	SMBH	TMBH	SMBH
26000	75	1307	768	1308	680	1307	604	1307	532	1310	468	—	—	—	—	—	—
	73	1265	820	1266	730	1266	662	1265	586	1266	514	1269	449	—	—	—	—
	71	1224	873	1225	781	1226	712	1226	644	1225	567	1226	495	—	—	—	—
	67	1146	985	1146	888	1147	817	1147	746	1148	675	1147	598	1147	523	1149	454
	62	1122	1122	1080	1079	1056	958	1055	881	1056	806	1056	733	1056	659	1055	582
28000	75	1324	789	1325	696	1323	616	1323	540	1326	473	—	—	—	—	—	—
	73	1282	844	1282	748	1283	677	1281	597	1282	521	1285	452	—	—	—	—
	71	1240	901	1241	803	1242	730	1242	658	1241	577	1241	501	—	—	—	—
	67	1161	1019	1162	917	1162	841	1163	766	1163	691	1162	610	1162	531	1164	458
	62	1149	1149	1106	1106	1077	1009	1070	909	1070	831	1070	753	1071	675	1070	593
30000	75	1339	809	1339	711	1337	627	1337	548	1340	477	—	—	—	—	—	—
	73	1296	867	1297	766	1297	692	1296	608	1296	528	1299	456	—	—	—	—
	71	1255	927	1256	824	1256	748	1256	672	1255	587	1255	507	—	—	—	—
	67	1179	1064	1176	945	1176	865	1176	785	1177	707	1175	622	1175	539	1178	462
	62	1174	1174	1129	1129	1097	1060	1083	938	1083	855	1083	772	1084	690	1082	604
32000	75	1352	827	1352	725	1351	638	1350	555	1353	481	—	—	—	—	—	—
	73	1309	889	1310	783	1310	705	1309	618	1308	534	1311	459	—	—	—	—
	71	1268	952	1268	844	1269	764	1269	685	1267	597	1268	513	—	—	—	—
	67	1198	1116	1188	971	1188	887	1189	804	1189	722	1189	639	1188	549	1189	465
	62	1197	1197	1150	1151	1117	1110	1095	965	1095	877	1095	791	1095	705	1095	619
34000	75	1364	845	1364	739	1362	648	1362	563	1364	485	—	—	—	—	—	—
	73	1321	910	1322	800	1322	718	1320	628	1320	540	1323	462	—	—	—	—
	71	1279	976	1280	863	1280	780	1280	697	1279	606	1279	518	—	—	—	—
	67	1219	1178	1199	997	1200	909	1200	822	1200	736	1200	650	1199	556	1200	468
	62	1218	1218	1170	1170	1136	1137	1105	990	1105	900	1106	809	1106	719	1105	629
36000	75	1375	863	1375	752	1375	670	1373	574	1375	488	—	—	—	—	—	—
	73	1332	930	1332	816	1333	731	1330	637	1330	546	1333	464	—	—	—	—
	71	1290	999	1290	882	1291	795	1291	709	1289	614	1289	523	—	—	—	—
	67	1242	1240	1209	1022	1210	930	1210	839	1210	750	1210	660	1209	563	1210	471
	62	1238	1238	1189	1189	1154	1154	1121	1039	1115	921	1115	826	1115	732	1115	639
38000	75	1385	879	1385	764	1385	679	1383	581	1384	492	—	—	—	—	—	—
	73	1342	949	1342	831	1342	743	1340	645	1339	552	1342	467	—	—	—	—
	71	1300	1022	1300	900	1300	809	1300	720	1298	622	1298	527	—	—	—	—
	67	1260	1260	1219	1046	1219	951	1219	856	1219	763	1219	670	1218	569	1219	474
	62	1257	1257	1206	1206	1170	1170	1135	1083	1124	941	1124	843	1124	746	1123	648
40000	75	1394	895	1394	776	1394	688	1392	587	1393	495	—	—	—	—	—	—
	73	1351	968	1351	845	1351	754	1351	665	1348	557	1351	469	—	—	—	—
	71	1308	1044	1309	917	1309	824	1309	731	1307	630	1307	532	—	—	—	—
	67	1277	1277	1227	1069	1227	971	1228	873	1228	776	1227	680	1226	575	1227	476
	62	1274	1274	1222	1222	1185	1185	1149	1128	1132	961	1132	859	1132	758	1131	657
42000	75	1402	911	1403	788	1402	697	1400	593	1401	498	—	—	—	—	—	—
	73	1359	986	1359	859	1359	766	1359	673	1357	568	1359	472	—	—	—	—
	71	1317	1065	1317	934	1317	837	1317	741	1315	637	1314	536	—	—	—	—
	67	1292	1292	1240	1114	1235	990	1236	888	1235	788	1235	689	1233	581	1235	479
	62	1290	1290	1237	1237	1199	1199	1164	1164	1139	981	1139	875	1139	770	1138	666
44000	75	1410	926	1410	799	1410	706	1408	599	1409	501	—	—	—	—	—	—
	73	1367	1004	1367	873	1367	776	1366	681	1364	573	1366	474	—	—	—	—
	71	1324	1085	1324	950	1325	850	1325	752	1322	644	1322	540	—	—	—	—
	67	1307	1307	1253	1164	1243	1008	1243	904	1243	800	1242	698	1240	587	1242	481
	62	1305	1305	1251	1251	1212	1213	1176	1176	1146	1000	1146	891	1146	782	1145	674
46000	75	1417	940	1417	810	1417	714	1415	605	1416	504	—	—	—	—	—	—
	73	1374	1021	1374	886	1374	787	1373	689	1371	577	1373	476	—	—	—	—
	71	1331	1105	1331	966	1331	863	1331	762	1330	661	1328	544	—	—	—	—
	67	1321	1321	1265	1214	1249	1027	1250	919	1249	812	1249	706	1247	592	1248	483
	62	1319	1319	1265	1265	1225	1225	1188	1188	1153	1023	1152	905	1152	793	1151	682

* Rated performance is at sea level. Cooling capacities are gross cooling capacity.

TABLE 17 – COOLING PERFORMANCE DATA* – 106 TON MODEL (cont'd)

95° AIR ON CONDENSER COIL

CFM	ENTERING WB (°F)	CAPACITY (mbh) AT ENTERING DRY BULB (°F)															
		90		86		83		80		77		74		71		68	
		TMBH	SMBH	TMBH	SMBH	TMBH	SMBH	TMBH	SMBH	TMBH	SMBH	TMBH	SMBH	TMBH	SMBH	TMBH	SMBH
26000	75	1259	749	1260	661	1259	586	1258	514	1261	450	—	—	—	—	—	—
	73	1219	801	1220	711	1220	644	1219	568	1219	496	1222	431	—	—	—	—
	71	1179	854	1180	762	1180	693	1181	625	1180	549	1180	477	—	—	—	—
	67	1104	965	1104	869	1105	797	1105	727	1105	656	1104	580	1104	505	1107	436
	62	1089	1089	1048	1048	1021	950	1016	861	1017	787	1017	713	1017	640	1016	563
28000	75	1275	770	1275	677	1274	598	1273	522	1276	455	—	—	—	—	—	—
	73	1234	825	1235	729	1235	659	1234	579	1234	503	1236	435	—	—	—	—
	71	1194	881	1195	784	1195	711	1196	639	1194	559	1195	483	—	—	—	—
	67	1119	1001	1119	897	1119	822	1120	747	1120	672	1118	592	1118	513	1121	440
	62	1115	1115	1072	1072	1041	1001	1030	890	1030	811	1030	733	1031	656	1029	575
30000	75	1289	789	1289	692	1287	609	1286	529	1289	459	—	—	—	—	—	—
	73	1248	847	1248	747	1249	673	1247	589	1247	510	1250	438	—	—	—	—
	71	1208	907	1208	804	1209	728	1209	653	1207	569	1208	489	—	—	—	—
	67	1140	1059	1131	925	1132	845	1132	766	1132	687	1132	609	1131	524	1133	443
	62	1139	1139	1095	1095	1062	1053	1042	917	1042	835	1042	753	1043	671	1042	588
32000	75	1301	808	1301	706	1299	619	1298	537	1301	463	—	—	—	—	—	—
	73	1260	869	1260	764	1261	686	1259	599	1258	516	1261	441	—	—	—	—
	71	1220	932	1220	824	1221	744	1221	665	1219	578	1219	494	—	—	—	—
	67	1161	1121	1143	951	1143	867	1144	785	1144	702	1143	620	1142	531	1144	447
	62	1161	1161	1115	1115	1082	1082	1053	944	1053	857	1053	771	1053	685	1053	600
34000	75	1312	826	1313	719	1312	641	1311	549	1312	467	—	—	—	—	—	—
	73	1271	889	1271	780	1272	699	1269	609	1269	522	1272	444	—	—	—	—
	71	1231	955	1231	843	1231	760	1231	677	1230	587	1230	499	—	—	—	—
	67	1184	1183	1153	976	1154	889	1154	802	1154	716	1154	631	1152	538	1154	450
	62	1181	1181	1134	1134	1100	1100	1068	989	1063	879	1063	789	1063	699	1062	610
36000	75	1322	842	1323	732	1322	650	1321	556	1322	470	—	—	—	—	—	—
	73	1281	909	1281	796	1281	711	1279	618	1278	528	1281	446	—	—	—	—
	71	1240	978	1241	862	1241	775	1241	689	1239	595	1239	504	—	—	—	—
	67	1203	1203	1163	1001	1163	910	1163	819	1163	730	1163	641	1162	544	1163	452
	62	1200	1200	1152	1152	1117	1117	1083	1035	1072	900	1072	806	1072	713	1071	619
38000	75	1331	859	1332	744	1331	660	1329	562	1330	473	—	—	—	—	—	—
	73	1290	929	1290	810	1290	723	1290	637	1287	533	1290	449	—	—	—	—
	71	1249	1001	1250	879	1250	789	1250	700	1248	603	1248	509	—	—	—	—
	67	1220	1220	1172	1025	1172	930	1172	836	1172	743	1171	651	1170	550	1171	455
	62	1218	1218	1168	1168	1132	1132	1097	1081	1080	921	1080	823	1080	725	1079	629
40000	75	1340	875	1340	756	1340	669	1338	568	1339	476	—	—	—	—	—	—
	73	1298	947	1299	825	1299	734	1298	645	1296	543	1298	451	—	—	—	—
	71	1258	1022	1258	897	1258	803	1258	711	1256	610	1255	513	—	—	—	—
	67	1236	1236	1185	1074	1180	950	1180	852	1180	756	1179	660	1178	556	1179	457
	62	1234	1234	1184	1184	1147	1147	1112	1112	1087	940	1087	839	1087	738	1086	637
42000	75	1348	890	1348	768	1347	677	1345	574	1346	479	—	—	—	—	—	—
	73	1306	965	1306	839	1306	745	1305	653	1304	549	1305	453	—	—	—	—
	71	1265	1044	1265	913	1266	817	1265	721	1263	618	1263	517	—	—	—	—
	67	1251	1251	1199	1124	1187	969	1187	868	1187	768	1186	669	1185	562	1186	460
	62	1250	1250	1198	1198	1160	1160	1125	1125	1094	960	1094	854	1094	750	1093	646
44000	75	1355	905	1355	779	1354	686	1352	580	1353	482	—	—	—	—	—	—
	73	1313	983	1313	852	1313	756	1312	661	1311	554	1312	455	—	—	—	—
	71	1272	1064	1272	929	1272	830	1272	731	1271	634	1269	521	—	—	—	—
	67	1266	1265	1213	1178	1194	987	1194	883	1194	779	1193	678	1191	568	1192	462
	62	1264	1264	1211	1211	1173	1173	1136	1137	1102	988	1101	870	1100	761	1099	654
46000	75	1361	919	1362	790	1361	694	1359	585	1359	485	—	—	—	—	—	—
	73	1320	1000	1320	866	1320	766	1319	669	1317	558	1318	457	—	—	—	—
	71	1281	1100	1279	945	1279	843	1279	741	1277	641	1275	525	—	—	—	—
	67	1279	1279	1229	1229	1200	1005	1200	898	1200	791	1199	686	1197	573	1198	464
	62	1277	1277	1224	1224	1185	1185	1148	1148	1114	1034	1106	884	1106	773	1105	662

* Rated performance is at sea level. Cooling capacities are gross cooling capacity.

Cooling Performance Data – 106 Ton Model (cont'd.)

TABLE 17 – COOLING PERFORMANCE DATA* – 106 TON MODEL (cont'd)

105° AIR ON CONDENSER COIL

CFM	ENTERING WB (°F)	CAPACITY (mbh) AT ENTERING DRY BULB (°F)															
		90		86		83		80		77		74		71		68	
		TMBH	SMBH	TMBH	SMBH	TMBH	SMBH	TMBH	SMBH	TMBH	SMBH	TMBH	SMBH	TMBH	SMBH	TMBH	SMBH
26000	75	1208	729	1209	642	1207	567	1206	495	1209	432	—	—	—	—	—	—
	73	1169	780	1170	691	1170	624	1169	549	1169	477	1171	413	—	—	—	—
	71	1131	833	1132	742	1132	673	1133	606	1131	530	1132	458	—	—	—	—
	67	1059	943	1059	848	1060	777	1060	706	1060	636	1059	560	1059	486	1061	417
	62	1054	1054	1013	1013	984	940	975	840	975	767	975	693	975	621	974	544
28000	75	1222	749	1223	657	1221	578	1220	503	1223	436	—	—	—	—	—	—
	73	1183	804	1184	709	1184	639	1182	560	1182	484	1185	416	—	—	—	—
	71	1145	860	1146	763	1146	691	1146	619	1145	540	1145	464	—	—	—	—
	67	1078	996	1072	876	1073	801	1073	726	1073	652	1072	572	1072	497	1074	421
	62	1079	1079	1036	1036	1005	994	987	869	987	791	988	713	988	636	986	555
30000	75	1235	768	1235	671	1233	589	1232	510	1235	440	—	—	—	—	—	—
	73	1196	826	1196	726	1196	652	1194	570	1194	491	1197	419	—	—	—	—
	71	1157	885	1158	783	1158	708	1158	633	1157	549	1157	470	—	—	—	—
	67	1099	1058	1084	903	1085	824	1085	745	1085	667	1085	589	1084	504	1085	424
	62	1101	1101	1058	1058	1026	1026	998	896	999	814	999	732	999	651	998	570
32000	75	1246	787	1247	685	1244	599	1245	523	1246	444	—	—	—	—	—	—
	73	1207	847	1207	743	1208	666	1205	580	1205	497	1208	422	—	—	—	—
	71	1168	910	1169	803	1169	724	1169	645	1167	558	1167	475	—	—	—	—
	67	1125	1123	1095	929	1095	846	1095	764	1096	682	1095	600	1094	511	1095	427
	62	1122	1122	1077	1077	1045	1045	1014	941	1009	836	1009	750	1009	665	1008	580
34000	75	1256	804	1257	698	1256	620	1255	530	1256	447	—	—	—	—	—	—
	73	1217	868	1217	759	1217	678	1215	589	1215	503	1217	424	—	—	—	—
	71	1178	934	1179	822	1179	739	1179	657	1177	567	1177	480	—	—	—	—
	67	1144	1144	1104	955	1105	867	1105	781	1105	695	1104	610	1103	518	1104	430
	62	1141	1141	1095	1095	1062	1061	1028	986	1018	858	1018	768	1018	678	1017	589
36000	75	1266	821	1266	711	1266	630	1264	536	1265	451	—	—	—	—	—	—
	73	1226	888	1226	774	1227	690	1225	601	1224	510	1226	427	—	—	—	—
	71	1187	956	1188	840	1188	754	1188	668	1186	575	1186	484	—	—	—	—
	67	1161	1161	1114	982	1113	888	1113	798	1113	709	1113	620	1111	524	1113	433
	62	1159	1159	1112	1112	1077	1077	1044	1034	1026	878	1026	784	1026	691	1025	599
38000	75	1274	837	1275	723	1274	639	1272	543	1273	454	—	—	—	—	—	—
	73	1235	907	1235	789	1235	702	1234	616	1232	518	1234	429	—	—	—	—
	71	1196	979	1196	858	1196	768	1196	679	1194	583	1193	489	—	—	—	—
	67	1177	1177	1128	1033	1121	908	1121	814	1121	722	1121	630	1119	530	1120	435
	62	1176	1176	1127	1127	1092	1092	1058	1058	1033	899	1033	801	1033	704	1032	608
40000	75	1282	853	1282	735	1281	648	1279	548	1280	457	—	—	—	—	—	—
	73	1242	925	1242	803	1242	713	1241	624	1240	523	1241	431	—	—	—	—
	71	1203	1000	1203	875	1204	782	1203	690	1201	590	1200	493	—	—	—	—
	67	1193	1193	1142	1084	1129	927	1129	830	1129	734	1128	639	1126	536	1127	437
	62	1191	1191	1142	1142	1106	1106	1071	1071	1040	918	1040	817	1040	716	1039	616
42000	75	1289	868	1289	746	1288	656	1286	554	1287	460	—	—	—	—	—	—
	73	1249	943	1249	817	1249	724	1248	632	1247	529	1248	433	—	—	—	—
	71	1210	1021	1210	891	1210	795	1210	700	1209	606	1207	497	—	—	—	—
	67	1207	1207	1158	1145	1135	946	1135	846	1135	746	1134	648	1132	542	1133	440
	62	1206	1206	1156	1156	1118	1119	1083	1083	1049	954	1046	832	1046	728	1045	625
44000	75	1296	883	1296	757	1295	665	1293	560	1293	462	—	—	—	—	—	—
	73	1256	960	1256	831	1256	734	1255	640	1253	534	1254	435	—	—	—	—
	71	1220	1063	1217	907	1217	808	1216	710	1215	613	1213	501	—	—	—	—
	67	1220	1221	1172	1172	1141	965	1141	861	1141	758	1140	656	1138	547	1139	442
	62	1219	1219	1168	1168	1130	1131	1094	1094	1061	999	1052	847	1052	740	1051	633
46000	75	1302	897	1302	768	1301	672	1299	565	1299	465	—	—	—	—	—	—
	73	1262	977	1262	843	1262	745	1261	647	1259	538	1260	437	—	—	—	—
	71	1231	1114	1223	923	1223	820	1222	719	1221	620	1219	507	—	—	—	—
	67	1233	1233	1184	1184	1148	986	1147	875	1147	769	1146	664	1144	553	1145	444
	62	1232	1232	1180	1180	1142	1142	1105	1105	1070	1037	1058	862	1057	751	1056	641

* Rated performance is at sea level. Cooling capacities are gross cooling capacity.

TABLE 17 – COOLING PERFORMANCE DATA* – 106 TON MODEL (cont'd)

115° AIR ON CONDENSER COIL

CFM	ENTERING WB (°F)	CAPACITY (mbh) AT ENTERING DRY BULB (°F)															
		90		86		83		80		77		74		71		68	
		TMBH	SMBH	TMBH	SMBH	TMBH	SMBH	TMBH	SMBH	TMBH	SMBH	TMBH	SMBH	TMBH	SMBH	TMBH	SMBH
26000	75	1013	652	1013	566	1011	496	1010	429	1012	364	—	—	—	—	—	—
	73	982	712	980	615	980	549	979	479	978	409	980	345	—	—	—	—
	71	1080	811	1080	720	1081	652	1081	584	1079	509	1080	438	—	—	—	—
	67	1015	935	1011	826	1011	755	1012	685	1012	615	1010	540	1010	468	1012	397
	62	1016	1016	976	976	946	932	930	818	931	745	931	672	931	599	930	523
28000	75	1023	671	1023	581	1021	507	1021	436	1022	368	—	—	—	—	—	—
	73	993	739	991	632	991	563	989	488	988	417	990	347	—	—	—	—
	71	1092	838	1093	741	1093	669	1093	598	1092	519	1092	444	—	—	—	—
	67	1037	996	1023	854	1023	779	1023	704	1024	630	1023	557	1022	476	1024	401
	62	1039	1039	998	998	968	968	942	846	942	769	942	691	942	614	942	538
30000	75	1032	689	1032	594	1031	517	1031	446	1031	372	—	—	—	—	—	—
	73	1004	766	1000	648	1000	576	998	498	997	422	998	350	—	—	—	—
	71	1104	863	1104	761	1104	686	1104	611	1102	529	1103	449	—	—	—	—
	67	1063	1063	1034	880	1034	801	1034	723	1034	645	1034	568	1033	483	1034	404
	62	1060	1060	1018	1018	987	987	957	890	952	791	952	710	952	629	952	548
32000	75	1042	713	1041	607	1040	533	1039	452	1039	375	—	—	—	—	—	—
	73	1014	793	1008	664	1008	588	1006	507	1005	428	1006	352	—	—	—	—
	71	990	837	979	739	976	645	976	568	1112	537	1112	454	—	—	—	—
	67	1082	1082	1044	906	1044	823	1044	741	1044	660	1043	578	1042	490	1043	407
	62	1080	1080	1036	1036	1004	1004	972	936	961	814	961	728	961	643	960	558
34000	75	1050	736	1048	620	1047	543	1046	459	1046	378	—	—	—	—	—	—
	73	1023	812	1015	679	1015	600	1158	—	1012	435	1013	355	—	—	—	—
	71	999	855	988	763	983	660	983	579	981	493	980	409	—	—	—	—
	67	1100	1100	1054	937	1052	844	1053	758	1052	673	1052	588	1050	497	1052	409
	62	1098	1098	1053	1053	1020	1020	989	986	969	835	970	745	969	656	969	568
36000	75	1058	757	1055	631	1054	552	1052	465	1052	381	—	—	—	—	—	—
	73	1032	828	1023	700	1022	611	1021	530	1019	441	1019	357	—	—	—	—
	71	1007	873	996	785	990	674	989	590	987	501	986	415	—	—	—	—
	67	996	997	1068	987	1060	865	1060	775	1060	686	1060	598	1058	503	1059	412
	62	995	995	1069	1069	1035	1035	1003	1003	977	855	977	762	977	669	976	577
38000	75	1065	778	1061	643	1060	560	1058	470	1058	384	—	—	—	—	—	—
	73	1040	843	1029	714	1028	622	1027	538	1025	446	1025	359	—	—	—	—
	71	1015	890	1003	798	996	693	995	600	993	508	992	419	—	—	—	—
	67	1009	1009	1082	1041	1067	885	1068	791	1067	699	1067	607	1065	509	1066	414
	62	1008	1008	1083	1083	1049	1049	1016	1015	984	877	984	778	983	681	982	585
40000	75	1072	804	1066	654	1066	568	1064	476	1063	386	—	—	—	—	—	—
	73	1047	857	1035	733	1033	633	1032	545	1030	451	1030	360	—	—	—	—
	71	1022	911	1010	812	1002	711	1000	610	999	521	997	422	—	—	—	—
	67	1021	1021	1100	1100	1074	904	1074	807	1074	711	1073	616	1071	514	1072	416
	62	1021	1021	1097	1097	1062	1062	1027	1027	995	920	990	794	989	693	988	594
42000	75	1079	822	1072	665	1071	576	1069	481	1068	389	—	—	—	—	—	—
	73	1053	871	1042	756	1038	643	1037	552	1035	456	1035	362	—	—	—	—
	71	1031	944	1016	825	1008	728	1005	619	1004	527	1002	426	—	—	—	—
	67	1033	1033	989	989	1080	923	1080	822	1080	723	1079	625	1077	520	1078	418
	62	1032	1032	1110	1110	1074	1074	1039	1039	1006	964	996	809	995	705	994	602
44000	75	1085	833	1076	675	1076	584	1073	486	1073	391	—	—	—	—	—	—
	73	1059	885	1047	773	1043	653	1042	560	1040	460	1040	364	—	—	—	—
	71	1042	983	1022	837	1013	744	1010	628	1009	534	1007	432	—	—	—	—
	67	1043	1043	999	999	1088	954	1086	837	1085	734	1084	633	1082	525	1083	420
	62	1042	1042	997	997	1085	1085	1049	1049	1015	1001	1001	824	1000	716	999	610
46000	75	1090	845	1081	685	1080	591	1078	491	1077	394	—	—	—	—	—	—
	73	1065	898	1053	794	1047	662	1046	566	1044	464	1044	365	—	—	—	—
	71	1053	1027	1027	849	1019	763	1014	637	1013	540	1011	436	—	—	—	—
	67	1053	1053	1008	1008	1096	992	1091	852	1091	746	1089	641	1088	531	1088	422
	62	1052	1052	1006	1006	1095	1095	1059	1059	1025	1025	1006	838	1005	728	1004	618

* Rated performance is at sea level. Cooling capacities are gross cooling capacity.

Cooling Performance Data – 110 Ton Model

TABLE 18 – COOLING PERFORMANCE DATA* – 110 TON MODEL

85° AIR ON CONDENSER COIL

CFM	ENTERING WB (°F)	CAPACITY (mbh) AT ENTERING DRY BULB (°F)															
		90		86		83		80		77		74		71		68	
		TMBH	SMBH	TMBH	SMBH	TMBH	SMBH	TMBH	SMBH	TMBH	SMBH	TMBH	SMBH	TMBH	SMBH	TMBH	SMBH
26000	75	1386	831	1387	733	1385	652	1386	579	1387	503	—	—	—	—	—	—
	73	1341	887	1342	787	1343	712	1341	632	1341	553	1344	481	—	—	—	—
	71	1298	944	1298	843	1299	767	1299	691	1298	610	1298	532	—	—	—	—
	67	1218	1073	1214	957	1215	879	1215	801	1216	724	1216	646	1215	564	1217	485
	62	1184	1184	1140	1137	1124	1042	1116	945	1117	865	1117	785	1118	705	1118	625
28000	75	1404	856	1405	752	1405	674	1404	589	1405	508	—	—	—	—	—	—
	73	1359	916	1360	810	1360	730	1358	645	1359	565	1361	485	—	—	—	—
	71	1315	977	1316	869	1316	788	1317	708	1315	622	1315	539	—	—	—	—
	67	1239	1124	1231	991	1232	908	1232	825	1232	743	1233	660	1232	574	1233	490
	62	1215	1215	1168	1168	1144	1090	1132	979	1133	893	1133	808	1134	723	1134	638
30000	75	1420	880	1420	770	1420	688	1419	598	1420	513	—	—	—	—	—	—
	73	1374	943	1375	831	1376	748	1375	662	1374	574	1376	488	—	—	—	—
	71	1330	1008	1331	894	1331	809	1332	724	1330	634	1330	545	—	—	—	—
	67	1258	1174	1246	1024	1246	936	1247	849	1247	761	1247	674	1246	582	1247	494
	62	1243	1242	1194	1194	1163	1134	1150	1021	1147	921	1147	831	1148	741	1147	651
32000	75	1434	903	1434	788	1434	701	1433	607	1433	517	—	—	—	—	—	—
	73	1388	970	1389	852	1389	764	1389	676	1388	582	1389	492	—	—	—	—
	71	1344	1038	1345	918	1345	829	1345	740	1343	645	1343	552	—	—	—	—
	67	1277	1222	1259	1056	1260	963	1260	871	1260	779	1260	687	1259	591	1260	497
	62	1268	1268	1218	1218	1183	1177	1165	1061	1159	948	1160	853	1160	758	1160	663
34000	75	1447	925	1447	804	1447	714	1445	616	1446	522	—	—	—	—	—	—
	73	1401	996	1401	872	1402	780	1401	688	1400	589	1401	495	—	—	—	—
	71	1356	1068	1357	942	1357	848	1358	755	1356	659	1356	561	—	—	—	—
	67	1296	1271	1272	1091	1271	990	1272	893	1272	796	1272	700	1270	599	1271	501
	62	1292	1292	1241	1241	1204	1204	1180	1100	1171	974	1171	874	1171	775	1171	675
36000	75	1458	947	1459	821	1458	727	1456	624	1457	526	—	—	—	—	—	—
	73	1412	1021	1413	892	1413	796	1413	700	1411	596	1412	498	—	—	—	—
	71	1367	1097	1368	965	1368	867	1369	769	1368	672	1366	567	—	—	—	—
	67	1317	1315	1287	1132	1282	1015	1283	914	1283	813	1282	712	1281	607	1281	504
	62	1314	1314	1261	1261	1223	1223	1193	1137	1181	1000	1181	895	1182	791	1181	686
38000	75	1469	968	1469	837	1469	738	1466	632	1466	530	—	—	—	—	—	—
	73	1422	1045	1423	911	1423	811	1423	711	1421	603	1422	500	—	—	—	—
	71	1378	1125	1378	987	1379	885	1379	783	1378	681	1376	573	—	—	—	—
	67	1337	1337	1300	1175	1292	1040	1292	935	1293	829	1292	724	1290	614	1291	507
	62	1334	1334	1280	1280	1241	1241	1207	1174	1190	1025	1191	915	1191	806	1190	697
40000	75	1478	989	1479	852	1478	750	1476	640	1476	534	—	—	—	—	—	—
	73	1432	1069	1433	929	1433	825	1432	721	1430	610	1431	503	—	—	—	—
	71	1387	1152	1387	1009	1388	903	1388	797	1387	691	1385	578	—	—	—	—
	67	1355	1355	1313	1216	1301	1065	1301	955	1302	845	1301	735	1299	621	1299	509
	62	1353	1353	1298	1298	1258	1258	1221	1210	1202	1060	1199	935	1199	822	1198	708
42000	75	1487	1009	1487	867	1487	761	1484	648	1484	537	—	—	—	—	—	—
	73	1441	1093	1441	947	1441	839	1440	732	1438	616	1439	505	—	—	—	—
	71	1401	1200	1396	1030	1396	920	1396	810	1395	700	1393	584	—	—	—	—
	67	1373	1373	1325	1255	1309	1089	1310	974	1310	860	1309	747	1307	628	1307	512
	62	1371	1371	1315	1315	1274	1274	1236	1235	1210	1086	1207	955	1207	836	1206	718
44000	75	1495	1028	1495	881	1495	772	1492	655	1491	541	—	—	—	—	—	—
	73	1449	1115	1449	965	1449	853	1448	741	1446	623	1446	508	—	—	—	—
	71	1409	1229	1404	1051	1404	937	1404	823	1403	709	1401	589	—	—	—	—
	67	1389	1389	1337	1293	1317	1112	1317	993	1317	875	1316	757	1314	635	1314	515
	62	1388	1388	1331	1331	1289	1289	1249	1249	1220	1119	1214	973	1214	851	1213	728
46000	75	1502	1047	1503	895	1502	783	1499	662	1499	544	—	—	—	—	—	—
	73	1456	1138	1456	982	1457	866	1455	751	1453	629	1453	510	—	—	—	—
	71	1421	1273	1411	1071	1411	953	1411	835	1410	718	1408	594	—	—	—	—
	67	1405	1405	1350	1334	1328	1151	1324	1012	1324	890	1323	768	1321	642	1321	517
	62	1403	1404	1346	1346	1303	1303	1262	1262	1230	1151	1221	992	1220	865	1219	738

* Rated performance is at sea level. Cooling capacities are gross cooling capacity.

TABLE 18 – COOLING PERFORMANCE DATA* – 110 TON MODEL (cont'd)

95° AIR ON CONDENSER COIL

CFM	ENTERING WB (°F)	CAPACITY (mbh) AT ENTERING DRY BULB (°F)															
		90		86		83		80		77		74		71		68	
		TMBH	SMBH	TMBH	SMBH	TMBH	SMBH	TMBH	SMBH	TMBH	SMBH	TMBH	SMBH	TMBH	SMBH	TMBH	SMBH
26000	75	1334	811	1335	713	1333	633	1334	559	1335	483	—	—	—	—	—	—
	73	1291	866	1292	767	1292	692	1291	612	1291	537	1293	461	—	—	—	—
	71	1249	923	1250	822	1250	746	1251	671	1249	590	1249	512	—	—	—	—
	67	1174	1055	1169	936	1169	858	1170	781	1170	703	1170	626	1169	545	1171	466
	62	1149	1149	1106	1106	1084	1024	1074	924	1075	844	1075	764	1076	684	1076	605
28000	75	1351	835	1351	731	1351	654	1350	569	1351	488	—	—	—	—	—	—
	73	1307	895	1308	789	1309	710	1307	625	1307	546	1309	465	—	—	—	—
	71	1265	956	1266	848	1266	768	1267	688	1265	602	1265	519	—	—	—	—
	67	1194	1106	1184	970	1185	887	1185	805	1186	722	1186	640	1184	554	1185	470
	62	1178	1178	1133	1133	1104	1071	1092	965	1090	872	1090	787	1090	703	1090	618
30000	75	1365	859	1366	749	1366	668	1364	578	1365	493	—	—	—	—	—	—
	73	1322	922	1322	810	1323	727	1323	644	1321	554	1323	469	—	—	—	—
	71	1279	987	1280	873	1280	788	1281	704	1279	614	1278	526	—	—	—	—
	67	1214	1158	1198	1002	1198	915	1199	827	1199	740	1199	654	1198	562	1199	474
	62	1205	1205	1157	1158	1124	1115	1108	1006	1103	900	1103	810	1103	720	1103	630
32000	75	1378	882	1379	767	1379	681	1377	587	1377	498	—	—	—	—	—	—
	73	1335	949	1335	831	1336	743	1335	656	1334	562	1335	472	—	—	—	—
	71	1292	1017	1293	897	1293	808	1293	719	1291	624	1291	535	—	—	—	—
	67	1233	1207	1213	1042	1211	942	1211	850	1211	758	1211	666	1210	571	1210	477
	62	1229	1229	1180	1180	1145	1145	1123	1045	1114	927	1115	832	1115	737	1114	643
34000	75	1390	904	1391	783	1390	693	1388	596	1389	502	—	—	—	—	—	—
	73	1346	974	1347	851	1347	759	1347	668	1345	569	1346	475	—	—	—	—
	71	1303	1046	1304	920	1304	827	1304	734	1304	641	1302	541	—	—	—	—
	67	1254	1253	1226	1079	1222	968	1222	871	1222	775	1222	679	1220	579	1221	480
	62	1252	1252	1202	1202	1165	1165	1136	1082	1125	953	1125	853	1125	753	1125	654
36000	75	1401	926	1401	800	1401	706	1399	604	1399	506	—	—	—	—	—	—
	73	1357	999	1357	870	1358	774	1357	679	1355	576	1356	478	—	—	—	—
	71	1314	1074	1314	943	1315	845	1315	748	1314	651	1312	547	—	—	—	—
	67	1275	1275	1240	1121	1232	993	1232	892	1232	791	1232	691	1230	586	1230	483
	62	1273	1273	1221	1221	1183	1183	1150	1119	1135	981	1135	873	1135	769	1134	665
38000	75	1411	946	1411	815	1410	717	1408	612	1408	510	—	—	—	—	—	—
	73	1366	1023	1367	889	1367	789	1366	689	1364	583	1365	480	—	—	—	—
	71	1323	1102	1324	965	1324	863	1324	761	1323	660	1321	552	—	—	—	—
	67	1294	1294	1253	1162	1241	1018	1241	913	1241	807	1241	703	1239	593	1239	486
	62	1292	1292	1240	1239	1201	1201	1164	1155	1146	1013	1143	893	1143	785	1142	676
40000	75	1419	967	1420	830	1419	729	1417	619	1416	513	—	—	—	—	—	—
	73	1375	1047	1376	907	1376	803	1375	700	1373	589	1373	483	—	—	—	—
	71	1337	1149	1332	987	1333	881	1332	775	1331	670	1330	558	—	—	—	—
	67	1312	1312	1265	1202	1249	1042	1249	932	1250	823	1249	714	1246	600	1247	489
	62	1310	1310	1256	1256	1217	1217	1179	1179	1156	1046	1151	913	1151	800	1150	686
42000	75	1427	987	1428	845	1427	740	1424	627	1424	517	—	—	—	—	—	—
	73	1383	1070	1384	925	1384	817	1383	710	1380	596	1381	485	—	—	—	—
	71	1346	1178	1340	1008	1340	898	1340	788	1339	679	1337	563	—	—	—	—
	67	1328	1328	1277	1241	1257	1066	1257	952	1257	838	1256	725	1254	607	1254	491
	62	1327	1327	1272	1272	1232	1232	1193	1193	1166	1076	1158	932	1158	814	1157	697
44000	75	1435	1006	1435	859	1434	751	1432	634	1431	520	—	—	—	—	—	—
	73	1390	1093	1391	942	1391	831	1390	720	1387	602	1388	487	—	—	—	—
	71	1358	1224	1347	1028	1348	914	1347	801	1346	688	1344	568	—	—	—	—
	67	1344	1344	1291	1279	1268	1105	1264	971	1264	853	1263	735	1260	614	1260	494
	62	1343	1343	1287	1287	1246	1246	1206	1206	1175	1107	1165	951	1164	828	1163	707
46000	75	1442	1025	1442	873	1441	761	1438	641	1437	524	—	—	—	—	—	—
	73	1397	1115	1398	960	1398	844	1396	729	1394	608	1394	489	—	—	—	—
	71	1369	1266	1354	1049	1354	931	1354	813	1353	696	1350	573	—	—	—	—
	67	1359	1359	1305	1305	1275	1130	1270	989	1270	867	1269	746	1267	620	1267	496
	62	1358	1358	1301	1301	1259	1259	1219	1219	1184	1138	1171	969	1171	842	1169	716

* Rated performance is at sea level. Cooling capacities are gross cooling capacity.

Cooling Performance Data – 110 Ton Model (cont'd.)

TABLE 18 – COOLING PERFORMANCE DATA* – 110 TON MODEL (cont'd)

105° AIR ON CONDENSER COIL

CFM	ENTERING WB (°F)	CAPACITY (mbh) AT ENTERING DRY BULB (°F)															
		90		86		83		80		77		74		71		68	
		TMBH	SMBH	TMBH	SMBH	TMBH	SMBH	TMBH	SMBH	TMBH	SMBH	TMBH	SMBH	TMBH	SMBH	TMBH	SMBH
26000	75	1278	789	1279	691	1279	618	1278	538	1279	463	—	—	—	—	—	—
	73	1237	844	1238	745	1238	671	1236	591	1237	517	1238	441	—	—	—	—
	71	1197	901	1197	800	1198	725	1198	650	1197	569	1197	491	—	—	—	—
	67	1128	1038	1120	914	1120	836	1121	759	1121	682	1121	605	1120	524	1121	445
28000	62	1111	1111	1068	1068	1042	1006	1032	909	1030	822	1030	742	1031	663	1030	584
	75	1294	813	1294	710	1294	632	1293	548	1293	468	—	—	—	—	—	—
	73	1252	872	1253	767	1253	688	1253	610	1252	525	1253	444	—	—	—	—
	71	1211	933	1212	826	1213	746	1213	666	1211	581	1211	498	—	—	—	—
30000	67	1148	1089	1134	947	1135	864	1135	782	1135	700	1135	618	1134	532	1135	449
	62	1139	1139	1094	1094	1062	1051	1047	944	1044	850	1044	765	1044	681	1044	596
	75	1307	837	1308	727	1307	646	1306	557	1306	472	—	—	—	—	—	—
	73	1265	899	1266	788	1266	705	1266	622	1264	533	1265	448	—	—	—	—
32000	71	1225	964	1225	850	1226	766	1226	681	1224	592	1224	507	—	—	—	—
	67	1167	1140	1149	987	1147	892	1148	805	1148	718	1147	632	1146	541	1147	453
	62	1164	1164	1118	1118	1084	1084	1062	985	1055	877	1056	787	1056	698	1055	609
	75	1319	859	1320	745	1319	659	1317	566	1317	477	—	—	—	—	—	—
34000	73	1277	925	1278	808	1278	721	1277	634	1276	540	1277	451	—	—	—	—
	71	1236	993	1237	874	1237	785	1237	697	1236	608	1235	513	—	—	—	—
	67	1189	1187	1162	1024	1158	919	1159	827	1159	736	1159	644	1157	549	1158	456
	62	1187	1187	1139	1139	1104	1104	1077	1026	1066	904	1066	809	1067	715	1066	620
36000	75	1330	881	1330	761	1330	671	1328	574	1328	481	—	—	—	—	—	—
	73	1288	951	1288	828	1289	737	1288	645	1286	547	1287	454	—	—	—	—
	71	1247	1022	1247	897	1248	804	1248	711	1247	618	1245	519	—	—	—	—
	67	1210	1210	1176	1066	1169	944	1169	848	1169	752	1168	657	1167	557	1167	459
38000	62	1208	1208	1159	1159	1123	1123	1091	1063	1078	938	1076	830	1076	731	1075	632
	75	1340	902	1340	777	1339	683	1337	582	1337	485	—	—	—	—	—	—
	73	1297	975	1298	847	1298	752	1297	656	1295	554	1296	456	—	—	—	—
	71	1256	1051	1257	920	1257	822	1257	725	1256	628	1254	525	—	—	—	—
40000	67	1229	1229	1189	1107	1178	970	1178	869	1178	769	1177	668	1175	564	1176	462
	62	1228	1228	1178	1178	1141	1141	1106	1100	1088	964	1085	850	1085	746	1084	643
	75	1349	923	1349	792	1348	695	1346	590	1345	488	—	—	—	—	—	—
	73	1306	1000	1307	866	1307	766	1306	667	1304	561	1304	459	—	—	—	—
42000	71	1270	1097	1265	942	1266	840	1265	739	1264	638	1263	531	—	—	—	—
	67	1248	1248	1201	1146	1186	994	1186	889	1186	784	1185	680	1183	571	1184	464
	62	1246	1246	1195	1195	1157	1157	1121	1121	1098	997	1093	870	1092	761	1091	653
	75	1357	943	1357	807	1356	706	1353	597	1353	492	—	—	—	—	—	—
44000	73	1314	1023	1315	884	1315	780	1314	677	1311	568	1312	461	—	—	—	—
	71	1278	1126	1273	963	1274	858	1273	752	1272	647	1270	536	—	—	—	—
	67	1265	1265	1214	1187	1197	1032	1194	909	1194	800	1193	691	1191	578	1191	467
	62	1263	1263	1211	1211	1172	1172	1135	1135	1108	1030	1100	889	1099	776	1098	664
46000	75	1364	963	1364	822	1363	717	1361	605	1360	495	—	—	—	—	—	—
	73	1322	1046	1322	902	1322	794	1321	687	1318	574	1319	463	—	—	—	—
	71	1290	1171	1280	984	1281	874	1280	765	1279	656	1277	541	—	—	—	—
	67	1281	1281	1229	1225	1205	1058	1201	928	1201	815	1200	702	1197	585	1197	469
48000	62	1279	1279	1226	1226	1187	1187	1148	1148	1117	1060	1106	908	1106	791	1105	674
	75	1371	982	1371	836	1370	728	1367	612	1366	499	—	—	—	—	—	—
	73	1328	1068	1329	919	1328	807	1327	697	1325	580	1325	466	—	—	—	—
	71	1302	1217	1287	1004	1287	891	1287	777	1285	665	1283	546	—	—	—	—
50000	67	1295	1295	1243	1243	1214	1094	1207	947	1207	829	1206	712	1203	591	1203	472
	62	1294	1294	1240	1240	1200	1200	1161	1161	1126	1091	1112	927	1112	805	1111	683
	75	1377	1001	1377	850	1376	738	1375	627	1372	502	—	—	—	—	—	—
	73	1335	1090	1335	936	1335	821	1333	706	1331	586	1331	468	—	—	—	—
52000	71	1313	1259	1293	1024	1293	907	1293	790	1291	673	1289	551	—	—	—	—
	67	1309	1310	1255	1255	1223	1126	1213	965	1213	844	1212	723	1210	601	1209	474
	62	1308	1308	1253	1253	1212	1212	1172	1172	1135	1122	1118	945	1117	819	1116	693

* Rated performance is at sea level. Cooling capacities are gross cooling capacity.

TABLE 18 – COOLING PERFORMANCE DATA* – 110 TON MODEL (cont'd)

115° AIR ON CONDENSER COIL

CFM	ENTERING WB (°F)	CAPACITY (mbh) AT ENTERING DRY BULB (°F)															
		90		86		83		80		77		74		71		68	
		TMBH	SMBH	TMBH	SMBH	TMBH	SMBH	TMBH	SMBH	TMBH	SMBH	TMBH	SMBH	TMBH	SMBH	TMBH	SMBH
26000	75	1066	707	1066	611	1066	539	1064	463	1064	389	—	—	—	—	—	—
	73	1034	771	1032	664	1032	591	1030	514	1030	441	1030	366	—	—	—	—
	71	1006	828	999	724	998	644	998	570	997	493	996	416	—	—	—	—
	67	1079	1020	1068	890	1068	813	1068	736	1069	659	1069	582	1067	501	1068	423
	62	1070	1070	1028	1028	998	985	985	886	982	798	982	719	983	640	982	561
28000	75	1078	735	1077	628	1077	552	1075	472	1075	393	—	—	—	—	—	—
	73	1046	802	1042	685	1043	607	1042	530	1041	449	1040	369	—	—	—	—
	71	1019	853	1011	751	1009	664	1009	585	1007	503	1007	425	—	—	—	—
	67	1099	1073	1081	923	1081	841	1081	759	1082	677	1081	595	1080	510	1081	427
	62	1096	1096	1052	1052	1021	1021	1001	927	994	826	995	742	995	657	994	573
30000	75	1088	761	1087	645	1086	565	1085	480	1084	397	—	—	—	—	—	—
	73	1057	831	1053	709	1052	623	1051	541	1050	456	1049	372	—	—	—	—
	71	1031	877	1021	777	1018	683	1018	600	1017	515	1016	431	—	—	—	—
	67	1000	999	1096	967	1092	868	1093	781	1093	695	1092	608	1091	518	1091	430
	62	999	999	1075	1075	1041	1041	1015	967	1005	853	1005	764	1005	674	1005	585
32000	75	1098	787	1095	661	1095	577	1093	488	1092	401	—	—	—	—	—	—
	73	1068	856	1062	729	1061	638	1060	552	1058	463	1058	375	—	—	—	—
	71	1042	901	1031	804	1028	705	1027	614	1026	527	1024	436	—	—	—	—
	67	1018	1018	1110	1009	1103	894	1103	803	1103	712	1102	621	1101	526	1101	433
	62	1017	1017	1095	1095	1061	1061	1029	1005	1016	885	1015	785	1015	691	1014	597
34000	75	1106	811	1103	677	1102	588	1100	496	1099	404	—	—	—	—	—	—
	73	1078	876	1070	752	1068	653	1067	563	1066	469	1065	377	—	—	—	—
	71	1052	923	1040	828	1036	727	1034	628	1033	536	1031	441	—	—	—	—
	67	1035	1035	997	946	1112	920	1112	824	1112	728	1111	633	1110	534	1110	436
	62	1034	1034	1114	1114	1078	1079	1045	1042	1027	914	1024	806	1023	707	1023	608
36000	75	949	789	940	629	939	538	937	445	935	352	—	—	—	—	—	—
	73	1087	895	1078	774	1075	667	1074	573	1072	475	1071	379	—	—	—	—
	71	1064	958	1049	846	1043	744	1041	641	1040	546	1038	447	—	—	—	—
	67	1050	1050	1008	975	989	870	981	794	976	687	974	585	1117	541	1118	439
	62	1049	1049	1005	1005	1095	1095	1060	1060	1037	947	1032	826	1031	722	1030	619
38000	75	956	817	945	643	944	548	942	452	939	355	—	—	—	—	—	—
	73	1095	914	1085	795	1081	681	1080	583	1078	482	1077	381	—	—	—	—
	71	1073	984	1057	863	1050	765	1047	654	1046	555	1044	452	—	—	—	—
	67	1064	1064	1020	1005	999	898	988	810	982	705	980	596	978	490	977	386
	62	1063	1064	1018	1018	1110	1110	1074	1074	1047	979	1039	845	1038	737	1037	629
40000	75	964	837	950	668	948	558	946	458	943	358	—	—	—	—	—	—
	73	1102	932	1091	814	1088	699	1086	593	1084	488	1082	383	—	—	—	—
	71	1084	1015	1064	880	1056	784	1052	666	1051	563	1049	456	—	—	—	—
	67	1078	1078	1032	1032	1006	918	995	825	988	722	985	606	983	497	982	388
	62	1077	1077	1030	1030	996	996	1088	1088	1056	1011	1045	865	1045	752	1044	639
42000	75	971	849	954	682	952	568	950	464	947	361	—	—	—	—	—	—
	73	1109	950	1097	833	1093	712	1091	602	1089	493	1087	385	—	—	—	—
	71	1094	1048	1070	896	1061	802	1058	683	1056	572	1054	461	—	—	—	—
	67	1090	1090	1043	1043	1015	943	1001	840	993	736	990	616	988	503	986	390
	62	1089	1089	1042	1042	1007	1007	1100	1100	1065	1041	1051	883	1051	766	1049	649
44000	75	977	859	959	700	955	578	954	473	950	363	—	—	—	—	—	—
	73	1115	967	1103	854	1098	725	1096	611	1093	499	1092	387	—	—	—	—
	71	1103	1076	1076	911	1067	822	1063	695	1061	580	1058	465	—	—	—	—
	67	1102	1102	1054	1054	1023	969	1006	854	998	752	995	626	993	512	991	392
	62	1101	1101	1053	1053	1017	1017	1112	1112	1076	1070	1057	902	1056	780	1055	659
46000	75	983	869	963	718	959	587	957	479	953	367	—	—	—	—	—	—
	73	971	907	944	822	931	678	1100	620	1098	504	1096	389	—	—	—	—
	71	1114	1107	1082	926	1073	838	1067	707	1065	588	1063	470	—	—	—	—
	67	1112	1112	1064	1064	1030	993	1012	868	1003	768	999	636	997	518	994	394
	62	1112	1112	1063	1063	1027	1027	991	991	1086	1086	1064	930	1061	793	1060	668

* Rated performance is at sea level. Cooling capacities are gross cooling capacity.

Cooling Performance Data – 115 Ton Model

TABLE 19 – COOLING PERFORMANCE DATA* – 115 TON MODEL

85° AIR ON CONDENSER COIL

CFM	ENTERING WB (°F)	CAPACITY (mbh) AT ENTERING DRY BULB (°F)															
		90		86		83		80		77		74		71		68	
		TMBH	SMBH	TMBH	SMBH	TMBH	SMBH	TMBH	SMBH	TMBH	SMBH	TMBH	SMBH	TMBH	SMBH	TMBH	SMBH
26000	75	1475	868	1476	769	1475	687	1475	610	1477	536	—	—	—	—	—	—
	73	1427	924	1428	824	1428	748	1427	667	1427	587	1430	514	—	—	—	—
	71	1380	982	1381	879	1382	803	1382	727	1381	645	1382	565	—	—	—	—
	67	1292	1103	1291	995	1292	916	1292	837	1293	759	1292	678	1293	598	1294	519
	62	1243	1243	1203	1170	1191	1073	1187	982	1187	901	1188	820	1188	740	1188	658
28000	75	1496	894	1496	789	1496	705	1495	620	1497	542	—	—	—	—	—	—
	73	1447	954	1448	847	1448	767	1447	680	1447	597	1450	519	—	—	—	—
	71	1400	1015	1401	906	1401	825	1402	744	1401	657	1401	573	—	—	—	—
	67	1312	1148	1310	1029	1311	946	1311	862	1312	779	1311	694	1311	608	1313	524
	62	1276	1276	1230	1217	1212	1119	1205	1016	1205	930	1206	845	1206	759	1206	674
30000	75	1514	919	1514	808	1513	719	1514	633	1515	547	—	—	—	—	—	—
	73	1465	982	1466	869	1466	785	1465	694	1465	606	1467	523	—	—	—	—
	71	1417	1047	1418	932	1419	846	1419	761	1418	669	1418	580	—	—	—	—
	67	1334	1200	1327	1063	1327	974	1328	886	1328	798	1329	710	1328	617	1329	528
	62	1306	1306	1257	1257	1232	1165	1222	1053	1221	959	1222	868	1222	777	1222	687
32000	75	1530	943	1531	826	1529	733	1530	643	1531	552	—	—	—	—	—	—
	73	1481	1010	1482	891	1482	802	1481	708	1480	614	1483	526	—	—	—	—
	71	1433	1078	1434	957	1434	867	1435	777	1433	681	1433	587	—	—	—	—
	67	1353	1248	1342	1096	1342	1002	1343	909	1343	816	1344	724	1342	626	1344	532
	62	1334	1334	1283	1283	1252	1212	1237	1088	1236	987	1236	891	1236	795	1236	700
34000	75	1545	966	1545	843	1545	752	1544	652	1545	557	—	—	—	—	—	—
	73	1495	1036	1496	911	1496	819	1495	721	1495	625	1497	530	—	—	—	—
	71	1447	1109	1448	982	1448	887	1449	793	1447	692	1447	594	—	—	—	—
	67	1372	1298	1356	1127	1356	1029	1357	931	1357	834	1357	737	1356	635	1357	536
	62	1360	1360	1307	1307	1271	1250	1253	1129	1248	1013	1249	913	1249	812	1249	712
36000	75	1558	988	1559	860	1559	765	1557	661	1557	561	—	—	—	—	—	—
	73	1508	1062	1509	932	1509	834	1508	732	1508	632	1509	533	—	—	—	—
	71	1460	1138	1461	1005	1461	906	1462	807	1460	704	1459	600	—	—	—	—
	67	1392	1349	1369	1163	1368	1055	1369	953	1369	851	1369	750	1368	643	1369	539
	62	1384	1384	1329	1329	1291	1286	1267	1163	1260	1040	1260	934	1261	829	1260	724
38000	75	1570	1009	1571	877	1570	778	1568	669	1569	566	—	—	—	—	—	—
	73	1520	1087	1521	951	1521	850	1521	749	1519	640	1521	536	—	—	—	—
	71	1472	1166	1472	1028	1473	925	1473	822	1471	715	1471	606	—	—	—	—
	67	1411	1388	1382	1198	1380	1081	1380	974	1380	868	1380	762	1378	651	1379	542
	62	1406	1406	1350	1350	1310	1311	1281	1202	1271	1065	1271	955	1271	845	1271	735
40000	75	1581	1031	1582	892	1581	790	1579	677	1580	570	—	—	—	—	—	—
	73	1531	1111	1532	970	1532	865	1531	760	1530	647	1531	539	—	—	—	—
	71	1482	1194	1483	1050	1484	943	1484	836	1482	725	1481	612	—	—	—	—
	67	1431	1426	1394	1231	1390	1106	1390	995	1391	884	1390	774	1388	658	1389	545
	62	1427	1427	1370	1370	1329	1329	1295	1240	1281	1093	1281	975	1281	860	1280	746
42000	75	1591	1051	1592	908	1591	801	1589	685	1589	574	—	—	—	—	—	—
	73	1541	1135	1542	989	1542	880	1541	771	1539	653	1541	541	—	—	—	—
	71	1492	1222	1493	1072	1493	960	1493	850	1492	739	1491	620	—	—	—	—
	67	1450	1450	1408	1275	1399	1130	1400	1015	1400	900	1400	786	1397	666	1398	548
	62	1447	1447	1388	1388	1346	1346	1309	1277	1291	1118	1290	995	1290	876	1289	757
44000	75	1601	1071	1601	923	1601	813	1598	693	1598	577	—	—	—	—	—	—
	73	1550	1158	1551	1006	1551	894	1550	781	1548	660	1549	544	—	—	—	—
	71	1503	1256	1502	1093	1502	978	1502	863	1501	749	1500	626	—	—	—	—
	67	1468	1468	1421	1317	1408	1154	1408	1034	1409	915	1408	797	1406	673	1406	551
	62	1465	1465	1406	1406	1362	1362	1322	1305	1300	1145	1298	1014	1298	890	1297	767
46000	75	1609	1091	1610	937	1609	824	1607	700	1607	581	—	—	—	—	—	—
	73	1559	1181	1560	1024	1560	907	1559	791	1557	666	1558	546	—	—	—	—
	71	1513	1289	1510	1114	1511	994	1511	876	1509	758	1508	631	—	—	—	—
	67	1485	1485	1433	1354	1417	1183	1417	1053	1417	930	1416	808	1414	680	1414	554
	62	1483	1483	1422	1422	1378	1378	1336	1332	1310	1180	1306	1033	1305	905	1304	777

* Rated performance is at sea level. Cooling capacities are gross cooling capacity.

TABLE 19 – COOLING PERFORMANCE DATA* – 115 TON MODEL (cont'd)

95° AIR ON CONDENSER COIL

CFM	ENTERING WB (°F)	CAPACITY (mbh) AT ENTERING DRY BULB (°F)															
		90		86		83		80		77		74		71		68	
		TMBH	SMBH	TMBH	SMBH	TMBH	SMBH	TMBH	SMBH	TMBH	SMBH	TMBH	SMBH	TMBH	SMBH	TMBH	SMBH
26000	75	1421	847	1422	748	1420	666	1420	589	1423	516	—	—	—	—	—	—
	73	1374	902	1375	802	1376	727	1375	646	1375	568	1377	494	—	—	—	—
	71	1329	960	1330	858	1331	781	1331	705	1330	624	1331	545	—	—	—	—
	67	1244	1081	1243	972	1244	894	1245	816	1245	738	1244	657	1245	577	1246	498
	62	1207	1207	1164	1146	1148	1052	1143	959	1143	879	1144	798	1144	718	1144	637
28000	75	1440	872	1441	767	1440	684	1440	602	1441	521	—	—	—	—	—	—
	73	1393	932	1394	825	1394	745	1393	659	1393	577	1396	498	—	—	—	—
	71	1348	992	1348	884	1349	803	1349	723	1348	636	1348	552	—	—	—	—
	67	1267	1134	1261	1007	1262	923	1262	840	1263	757	1263	674	1262	587	1263	503
	62	1238	1238	1191	1190	1169	1100	1161	996	1160	908	1161	823	1161	737	1161	652
30000	75	1457	896	1458	786	1456	698	1456	612	1457	526	—	—	—	—	—	—
	73	1410	960	1411	847	1411	763	1410	674	1409	585	1412	502	—	—	—	—
	71	1364	1025	1365	910	1365	824	1366	739	1364	648	1364	559	—	—	—	—
	67	1285	1180	1277	1040	1277	952	1278	864	1278	776	1278	689	1277	596	1278	507
	62	1267	1267	1218	1218	1189	1146	1176	1030	1175	936	1175	846	1176	755	1175	665
32000	75	1472	920	1473	804	1473	717	1471	621	1472	531	—	—	—	—	—	—
	73	1425	987	1425	868	1426	780	1424	687	1424	596	1426	505	—	—	—	—
	71	1379	1055	1379	935	1380	845	1380	755	1378	659	1378	567	—	—	—	—
	67	1305	1231	1291	1072	1291	979	1292	887	1292	794	1292	702	1291	605	1292	511
	62	1294	1294	1243	1243	1209	1187	1193	1073	1188	964	1189	868	1189	773	1189	678
34000	75	1486	943	1486	821	1486	730	1484	630	1485	536	—	—	—	—	—	—
	73	1438	1013	1439	889	1439	796	1437	699	1437	603	1439	508	—	—	—	—
	71	1392	1085	1392	959	1393	864	1393	770	1391	672	1391	573	—	—	—	—
	67	1326	1284	1305	1108	1304	1006	1304	909	1305	812	1304	715	1303	613	1304	514
	62	1318	1318	1266	1266	1229	1223	1206	1108	1200	990	1200	890	1201	790	1200	690
36000	75	1498	965	1498	838	1498	743	1496	639	1497	540	—	—	—	—	—	—
	73	1450	1038	1451	909	1451	812	1451	715	1449	611	1450	511	—	—	—	—
	71	1404	1114	1404	982	1405	883	1405	785	1403	682	1402	579	—	—	—	—
	67	1345	1323	1318	1143	1315	1032	1316	930	1316	829	1316	727	1314	621	1315	517
	62	1341	1341	1288	1288	1249	1249	1221	1147	1211	1016	1211	911	1211	806	1211	701
38000	75	1509	986	1510	854	1509	755	1507	647	1508	544	—	—	—	—	—	—
	73	1461	1063	1462	928	1462	827	1461	727	1460	618	1461	514	—	—	—	—
	71	1414	1143	1415	1005	1416	902	1415	799	1414	692	1413	585	—	—	—	—
	67	1365	1362	1332	1186	1326	1057	1326	951	1326	845	1326	739	1324	629	1325	521
	62	1363	1362	1308	1308	1268	1268	1235	1185	1222	1045	1221	931	1221	822	1220	712
40000	75	1519	1007	1520	870	1519	767	1517	655	1517	548	—	—	—	—	—	—
	73	1471	1088	1472	947	1472	842	1471	738	1469	625	1470	517	—	—	—	—
	71	1424	1170	1425	1027	1425	920	1425	813	1424	705	1423	593	—	—	—	—
	67	1385	1385	1344	1221	1335	1082	1336	971	1336	861	1335	751	1333	636	1334	523
	62	1383	1383	1326	1326	1286	1286	1249	1221	1231	1070	1230	951	1230	837	1229	723
42000	75	1529	1028	1529	885	1529	778	1526	663	1526	552	—	—	—	—	—	—
	73	1480	1111	1481	965	1481	856	1480	748	1478	631	1479	520	—	—	—	—
	71	1435	1205	1434	1048	1434	937	1434	826	1433	717	1432	598	—	—	—	—
	67	1403	1403	1357	1262	1344	1106	1344	991	1345	877	1344	762	1342	643	1342	526
	62	1401	1401	1344	1344	1302	1302	1263	1250	1240	1097	1238	971	1238	852	1237	734
44000	75	1537	1047	1538	900	1537	790	1534	671	1535	556	—	—	—	—	—	—
	73	1489	1134	1490	983	1490	870	1489	758	1486	638	1487	522	—	—	—	—
	71	1445	1238	1442	1069	1443	954	1443	840	1441	726	1440	603	—	—	—	—
	67	1421	1421	1370	1304	1353	1135	1352	1010	1353	892	1352	774	1349	650	1350	529
	62	1419	1419	1361	1360	1318	1318	1277	1276	1251	1131	1246	990	1246	867	1245	744
46000	75	1545	1067	1546	914	1545	800	1542	678	1542	559	—	—	—	—	—	—
	73	1497	1157	1497	1000	1498	884	1496	768	1494	644	1495	525	—	—	—	—
	71	1455	1269	1450	1090	1450	971	1450	852	1449	735	1447	609	—	—	—	—
	67	1437	1437	1383	1338	1361	1159	1360	1029	1360	907	1359	784	1357	657	1357	531
	62	1435	1435	1376	1376	1332	1332	1291	1291	1260	1162	1253	1009	1253	881	1252	754

* Rated performance is at sea level. Cooling capacities are gross cooling capacity.

Cooling Performance Data – 115 Ton Model (cont'd.)

TABLE 19 – COOLING PERFORMANCE DATA* – 115 TON MODEL (cont'd)

105° AIR ON CONDENSER COIL

CFM	ENTERING WB (°F)	CAPACITY (mbh) AT ENTERING DRY BULB (°F)															
		90		86		83		80		77		74		71		68	
		TMBH	SMBH	TMBH	SMBH	TMBH	SMBH	TMBH	SMBH	TMBH	SMBH	TMBH	SMBH	TMBH	SMBH	TMBH	SMBH
26000	75	1363	823	1363	725	1362	646	1363	570	1364	494	—	—	—	—	—	—
	73	1318	879	1319	779	1319	704	1318	623	1318	546	1320	472	—	—	—	—
	71	1275	936	1275	834	1276	758	1276	683	1275	601	1275	523	—	—	—	—
	67	1197	1066	1192	948	1193	870	1193	792	1194	715	1193	—	1193	555	1194	476
	62	1167	1167	1123	1119	1104	1033	1096	938	1096	855	1097	775	1097	695	1097	616
28000	75	1380	848	1381	744	1380	661	1380	580	1381	499	—	—	—	—	—	—
	73	1335	908	1336	802	1336	722	1335	637	1335	554	1337	476	—	—	—	—
	71	1292	968	1292	861	1293	780	1293	700	1292	614	1292	530	—	—	—	—
	67	1216	1112	1208	982	1209	899	1209	817	1210	734	1210	652	1209	564	1210	480
	62	1197	1197	1151	1151	1124	1080	1112	972	1111	884	1112	799	1112	714	1112	629
30000	75	1396	873	1396	763	1395	675	1395	590	1396	504	—	—	—	—	—	—
	73	1351	936	1351	823	1352	740	1350	651	1350	565	1352	480	—	—	—	—
	71	1307	1000	1307	886	1308	801	1308	716	1306	625	1306	538	—	—	—	—
	67	1236	1163	1223	1015	1223	927	1224	840	1224	752	1224	665	1223	573	1224	484
	62	1225	1225	1177	1177	1145	1123	1129	1013	1125	912	1126	822	1126	732	1125	642
32000	75	1410	896	1410	780	1410	694	1408	599	1409	509	—	—	—	—	—	—
	73	1364	962	1365	844	1365	756	1364	664	1364	573	1365	483	—	—	—	—
	71	1320	1031	1321	910	1321	821	1321	731	1319	636	1319	544	—	—	—	—
	67	1257	1215	1237	1052	1236	955	1237	862	1237	770	1237	678	1235	582	1236	488
	62	1250	1250	1200	1200	1165	1159	1143	1050	1137	939	1138	844	1138	749	1137	654
34000	75	1422	919	1423	797	1422	707	1421	608	1421	513	—	—	—	—	—	—
	73	1377	989	1377	865	1378	772	1376	678	1375	581	1377	486	—	—	—	—
	71	1332	1060	1333	934	1333	840	1333	746	1332	649	1331	550	—	—	—	—
	67	1276	1255	1250	1087	1248	981	1248	884	1249	788	1248	691	1247	590	1247	491
	62	1273	1273	1222	1222	1185	1185	1158	1089	1148	965	1149	865	1149	765	1148	666
36000	75	1434	940	1434	814	1433	719	1432	616	1432	518	—	—	—	—	—	—
	73	1388	1014	1388	884	1389	788	1388	692	1386	588	1387	489	—	—	—	—
	71	1343	1089	1344	957	1344	859	1344	761	1342	659	1341	556	—	—	—	—
	67	1297	1295	1265	1130	1258	1007	1259	905	1259	804	1258	703	1257	598	1258	494
	62	1295	1295	1243	1243	1204	1204	1172	1128	1159	994	1159	886	1159	781	1158	677
38000	75	1444	962	1444	830	1444	731	1441	624	1442	522	—	—	—	—	—	—
	73	1398	1038	1399	904	1399	803	1398	703	1396	595	1397	492	—	—	—	—
	71	1355	1124	1354	980	1354	877	1354	775	1352	669	1352	564	—	—	—	—
	67	1317	1317	1276	1164	1268	1032	1268	926	1269	821	1268	715	1266	605	1267	497
	62	1315	1315	1262	1262	1222	1222	1187	1162	1169	1022	1168	906	1168	797	1167	688
40000	75	1453	982	1454	845	1453	743	1451	632	1451	525	—	—	—	—	—	—
	73	1407	1062	1408	922	1408	818	1407	714	1405	601	1406	494	—	—	—	—
	71	1364	1152	1363	1002	1363	895	1363	789	1362	683	1360	569	—	—	—	—
	67	1336	1336	1290	1207	1278	1061	1277	946	1277	836	1276	727	1274	612	1275	500
	62	1334	1334	1279	1279	1239	1239	1201	1192	1178	1049	1176	926	1176	812	1175	699
42000	75	1462	1002	1462	860	1461	754	1459	640	1459	529	—	—	—	—	—	—
	73	1416	1086	1416	940	1416	832	1415	724	1413	608	1414	497	—	—	—	—
	71	1374	1185	1371	1023	1372	912	1371	802	1370	692	1368	575	—	—	—	—
	67	1353	1353	1303	1248	1286	1086	1285	966	1285	852	1284	738	1282	619	1282	503
	62	1352	1352	1296	1296	1255	1255	1216	1216	1189	1083	1183	946	1183	827	1182	709
44000	75	1470	1022	1470	875	1469	765	1467	647	1466	533	—	—	—	—	—	—
	73	1424	1109	1424	958	1424	846	1423	734	1421	614	1421	499	—	—	—	—
	71	1385	1224	1379	1044	1379	929	1379	815	1377	701	1376	580	—	—	—	—
	67	1370	1370	1316	1282	1295	1114	1293	985	1292	867	1292	749	1289	626	1289	505
	62	1369	1369	1312	1312	1269	1270	1229	1229	1199	1115	1190	964	1190	841	1189	719
46000	75	1477	1041	1478	889	1477	776	1474	654	1473	536	—	—	—	—	—	—
	73	1431	1131	1431	975	1431	859	1430	744	1428	620	1428	501	—	—	—	—
	71	1397	1267	1386	1064	1386	946	1386	827	1384	710	1382	585	—	—	—	—
	67	1385	1385	1330	1314	1302	1138	1299	1004	1299	881	1298	759	1296	633	1296	508
	62	1384	1384	1326	1326	1283	1283	1242	1242	1208	1145	1197	983	1196	856	1195	729

* Rated performance is at sea level. Cooling capacities are gross cooling capacity.

TABLE 19 – COOLING PERFORMANCE DATA* – 115 TON MODEL (cont'd)

115° AIR ON CONDENSER COIL

CFM	ENTERING WB (°F)	CAPACITY (mbh) AT ENTERING DRY BULB (°F)															
		90		86		83		80		77		74		71		68	
		TMBH	SMBH	TMBH	SMBH	TMBH	SMBH	TMBH	SMBH	TMBH	SMBH	TMBH	SMBH	TMBH	SMBH	TMBH	SMBH
26000	75	951	664	951	569	950	495	949	424	948	350						
	73	925	738	920	621	920	549	919	474	918	401	918	327				
	71	906	796	893	688	890	601	890	528	889	453	888	377				
	67	1144	1044	1137	923	1138	845	1138	768	1138	690	1138	613	1137	531	1139	453
	62	1124	1124	1081	1081	1056	1012	1046	912	1045	830	1045	750	1046	671	1045	591
28000	75	760	623	758	509	757	435	756	361	753	284						
	73	936	771	929	642	929	565	928	486	927	408	926	330				
	71	920	815	903	717	899	621	899	543	898	463	896	384				
	67	1164	1095	1152	957	1152	874	1153	791	1153	709	1153	627	1152	540	1153	457
	62	1153	1153	1107	1107	1077	1055	1062	951	1059	858	1059	774	1060	689	1059	604
30000	75	767	657	762	525	761	446	760	368	757	288						
	73	947	803	939	670	937	580	936	497	935	416	934	333				
	71	933	834	913	745	907	640	907	557	905	473	904	390				
	67	1062	1023	1166	993	1166	902	1166	814	1166	727	1166	640	1165	549	1166	460
	62	1057	1057	1131	1132	1097	1093	1077	991	1071	886	1072	796	1072	706	1071	617
32000	75	774	689	766	540	765	457	764	375	761	291						
	73	960	829	946	690	944	595	943	507	942	422	940	335				
	71	945	851	922	774	915	666	914	571	912	482	911	395				
	67	923	913	1179	1029	1177	929	1178	837	1178	745	1177	653	1176	557	1177	464
	62	922	922	1154	1154	1119	1119	1092	1031	1083	913	1083	818	1083	723	1082	629
34000	75	779	716	770	554	769	468	767	382	764	294						
	73	775	775	750	645	745	531	744	443	742	356	739	266				
	71	955	868	932	800	922	687	920	584	918	491	917	400				
	67	937	937	904	854	1018	869	1009	792	1006	688	1005	590	1003	493	1002	396
	62	936	936	1050	1050	1138	1138	1107	1070	1094	942	1093	839	1093	740	1092	640
36000	75	785	747	773	568	772	478	771	388	767	297						
	73	784	784	755	673	748	544	747	452	746	361	742	267				
	71	965	883	941	815	929	708	926	597	924	500	922	406				
	67	950	950	914	871	894	814	877	763	868	646	866	541	864	442	862	343
	62	949	949	908	908	1156	1156	1121	1101	1104	970	1102	860	1102	755	1101	651
38000	75	792	778	776	582	775	488	773	395	770	299						
	73	792	792	760	696	751	557	750	461	748	366	744	269				
	71	974	898	949	828	935	731	931	610	929	511	927	411				
	67	963	963	923	890	902	827	885	774	874	666	871	552	869	448	866	345
	62	962	962	919	919	1173	1173	1136	1131	1114	1001	1110	880	1110	771	1109	662
40000	75	800	800	781	612	778	497	776	400	772	302						
	73	800	800	765	721	754	570	753	470	751	371	746	270				
	71	982	913	957	840	941	753	935	622	934	520	932	415				
	67	974	974	932	909	910	840	892	785	879	683	875	562	873	454	870	347
	62	973	973	930	930	898	898	1151	1151	1123	1031	1118	899	1117	786	1116	673
42000	75	807	807	783	625	780	507	778	406	774	305						
	73	807	807	770	746	758	596	755	478	753	376	748	272				
	71	807	807	769	769	743	707	732	554	938	528	936	419				
	67	984	984	941	928	916	852	898	795	883	700	879	572	877	460	874	349
	62	984	984	940	940	907	907	1165	1165	1133	1065	1125	919	1124	800	1123	683
44000	75	814	814	787	648	782	516	780	412	776	307						
	73	813	813	775	770	761	608	757	487	755	381	750	273				
	71	813	813	775	775	747	731	736	577	733	456	730	348				
	67	813	813	950	946	923	864	904	805	888	718	883	582	881	466	878	350
	62	812	812	949	949	916	916	1178	1178	1143	1096	1131	937	1130	815	1129	693
46000	75	820	820	790	666	784	525	782	418	778	309						
	73	819	819	781	781	763	620	759	495	757	385	752	275				
	71	819	819	780	780	753	751	738	588	735	463	732	352				
	67	819	819	959	959	930	880	910	815	893	735	886	592	884	472	881	352
	62	818	818	958	958	924	924	891	891	1153	1123	1137	956	1136	829	1135	702

* Rated performance is at sea level. Cooling capacities are gross cooling capacity.

Cooling Performance Data – 130 Ton Model

TABLE 20 – COOLING PERFORMANCE DATA* – 130 TON MODEL

85° AIR ON CONDENSER COIL

CFM	ENTERING WB (°F)	CAPACITY (mbh) AT ENTERING DRY BULB (°F)															
		90		86		83		80		77		74		71		68	
		TMBH	SMBH	TMBH	SMBH	TMBH	SMBH	TMBH	SMBH	TMBH	SMBH	TMBH	SMBH	TMBH	SMBH	TMBH	SMBH
26000	75	1690	971	1691	866	1689	781	1690	701	1692	622	—	—	—	—	—	—
	73	1633	1029	1634	923	1635	843	1634	758	1634	675	1637	598	—	—	—	—
	71	1578	1089	1579	981	1580	900	1581	820	1580	735	1580	652	—	—	—	—
	67	1473	1210	1474	1099	1475	1017	1476	935	1477	853	1476	768	1477	685	1478	602
	62	1385	1385	1363	1269	1357	1175	1354	1083	1355	999	1355	915	1356	831	1356	747
28000	75	1717	1001	1718	889	1717	799	1718	715	1719	629	—	—	—	—	—	—
	73	1660	1063	1661	950	1661	865	1660	774	1660	686	1663	604	—	—	—	—
	71	1604	1127	1605	1012	1606	926	1607	840	1606	749	1606	661	—	—	—	—
	67	1498	1257	1500	1139	1500	1051	1501	963	1501	875	1502	788	1502	697	1503	608
	62	1425	1425	1390	1325	1381	1221	1378	1123	1378	1032	1379	943	1379	853	1380	763
30000	75	1741	1030	1742	911	1740	816	1741	727	1743	636	—	—	—	—	—	—
	73	1684	1096	1684	976	1685	886	1684	790	1684	698	1686	609	—	—	—	—
	71	1628	1164	1629	1042	1629	951	1630	860	1629	764	1629	670	—	—	—	—
	67	1526	1313	1522	1177	1523	1084	1523	991	1524	897	1524	805	1523	708	1525	614
	62	1462	1462	1416	1379	1405	1271	1398	1160	1399	1065	1400	969	1400	874	1400	779
32000	75	1763	1058	1764	933	1764	839	1763	738	1764	642	—	—	—	—	—	—
	73	1705	1128	1706	1001	1706	906	1705	805	1705	710	1707	614	—	—	—	—
	71	1649	1200	1649	1071	1650	974	1651	878	1649	777	1649	678	—	—	—	—
	67	1547	1360	1542	1215	1542	1116	1543	1017	1543	919	1544	821	1543	718	1544	619
	62	1497	1497	1442	1431	1426	1318	1417	1197	1418	1096	1418	995	1419	894	1419	794
34000	75	1782	1085	1783	953	1783	855	1782	749	1783	648	—	—	—	—	—	—
	73	1724	1159	1725	1025	1725	925	1723	819	1724	719	1726	618	—	—	—	—
	71	1667	1235	1668	1099	1669	998	1669	897	1667	790	1667	686	—	—	—	—
	67	1569	1414	1560	1251	1560	1147	1561	1043	1561	939	1562	836	1560	728	1561	623
	62	1529	1529	1471	1471	1446	1364	1437	1242	1435	1127	1435	1020	1435	914	1435	808
36000	75	1800	1111	1801	973	1801	871	1799	759	1800	653	—	—	—	—	—	—
	73	1741	1189	1742	1049	1743	944	1743	840	1741	728	1743	622	—	—	—	—
	71	1684	1269	1685	1126	1686	1020	1686	914	1684	802	1684	693	—	—	—	—
	67	1590	1463	1576	1286	1577	1177	1577	1068	1578	959	1578	851	1576	738	1577	628
	62	1559	1559	1499	1499	1466	1410	1453	1278	1450	1156	1450	1044	1451	933	1451	821
38000	75	1816	1137	1817	993	1817	885	1815	770	1815	659	—	—	—	—	—	—
	73	1757	1219	1758	1072	1758	963	1758	854	1756	737	1758	626	—	—	—	—
	71	1700	1302	1701	1153	1701	1042	1701	931	1699	814	1700	703	—	—	—	—
	67	1608	1512	1591	1321	1592	1207	1592	1092	1592	979	1592	865	1590	747	1592	632
	62	1587	1587	1525	1525	1485	1457	1471	1321	1464	1186	1464	1068	1465	951	1464	835
40000	75	1831	1162	1832	1012	1831	900	1829	780	1830	664	—	—	—	—	—	—
	73	1772	1247	1772	1094	1773	980	1772	867	1771	746	1772	629	—	—	—	—
	71	1714	1335	1715	1179	1715	1063	1716	948	1715	832	1713	710	—	—	—	—
	67	1627	1561	1609	1369	1605	1235	1606	1116	1606	997	1606	879	1604	756	1604	635
	62	1613	1613	1550	1550	1505	1498	1485	1356	1477	1214	1477	1092	1477	969	1477	847
42000	75	1845	1186	1845	1030	1845	914	1842	789	1843	668	—	—	—	—	—	—
	73	1785	1275	1786	1116	1786	998	1785	879	1783	754	1785	633	—	—	—	—
	71	1727	1367	1728	1205	1728	1084	1729	964	1728	844	1726	717	—	—	—	—
	67	1646	1611	1622	1404	1617	1264	1618	1140	1618	1016	1618	892	1616	764	1616	639
	62	1638	1638	1573	1573	1527	1527	1500	1397	1488	1242	1489	1114	1489	987	1488	860
44000	75	1857	1210	1858	1048	1857	927	1855	798	1855	673	—	—	—	—	—	—
	73	1797	1303	1798	1138	1798	1015	1797	892	1795	761	1796	636	—	—	—	—
	71	1739	1398	1740	1230	1740	1105	1740	980	1739	855	1738	724	—	—	—	—
	67	1666	1656	1636	1442	1629	1292	1630	1163	1630	1034	1629	906	1627	773	1627	642
	62	1661	1661	1595	1595	1547	1547	1514	1436	1500	1273	1500	1137	1500	1004	1499	872
46000	75	1869	1234	1869	1066	1869	941	1866	807	1866	677	—	—	—	—	—	—
	73	1809	1330	1809	1159	1810	1031	1809	904	1806	769	1807	639	—	—	—	—
	71	1750	1429	1751	1255	1751	1125	1752	995	1750	866	1748	730	—	—	—	—
	67	1688	1688	1650	1483	1640	1319	1640	1185	1640	1051	1640	918	1637	781	1638	646
	62	1683	1683	1615	1615	1566	1566	1527	1474	1513	1307	1510	1158	1510	1021	1509	884

* Rated performance is at sea level. Cooling capacities are gross cooling capacity.

TABLE 20 – COOLING PERFORMANCE DATA* – 130 TON MODEL (cont'd)

95° AIR ON CONDENSER COIL

CFM	ENTERING WB (°F)	CAPACITY (mbh) AT ENTERING DRY BULB (°F)															
		90		86		83		80		77		74		71		68	
		TMBH	SMBH	TMBH	SMBH	TMBH	SMBH	TMBH	SMBH	TMBH	SMBH	TMBH	SMBH	TMBH	SMBH	TMBH	SMBH
26000	75	1630	947	1631	842	1630	757	1631	679	1632	598	—	—	—	—	—	—
	73	1575	1005	1576	898	1577	819	1576	734	1576	652	1579	574	—	—	—	—
	71	1522	1063	1523	956	1524	876	1524	795	1524	711	1524	628	—	—	—	—
	67	1421	1184	1422	1074	1422	992	1423	910	1424	828	1424	746	1424	661	1425	578
	62	1345	1346	1315	1244	1308	1149	1305	1058	1306	974	1306	890	1307	806	1307	722
28000	75	1655	976	1656	865	1655	774	1656	691	1657	605	—	—	—	—	—	—
	73	1600	1038	1601	925	1602	840	1600	750	1600	662	1603	580	—	—	—	—
	71	1547	1101	1547	987	1548	901	1549	816	1548	725	1548	637	—	—	—	—
	67	1449	1241	1445	1113	1446	1026	1446	938	1447	850	1447	763	1447	672	1448	584
	62	1384	1384	1342	1300	1333	1200	1327	1096	1328	1007	1328	917	1329	828	1329	738
30000	75	1678	1005	1679	886	1677	791	1678	703	1679	612	—	—	—	—	—	—
	73	1622	1070	1623	951	1624	861	1622	765	1623	676	1625	585	—	—	—	—
	71	1568	1138	1569	1016	1570	925	1570	835	1569	739	1569	645	—	—	—	—
	67	1470	1288	1466	1151	1467	1058	1467	965	1468	872	1468	780	1467	683	1468	589
	62	1420	1420	1369	1354	1354	1245	1347	1134	1347	1039	1348	943	1348	848	1348	754
32000	75	1698	1032	1699	908	1699	814	1698	714	1698	618	—	—	—	—	—	—
	73	1642	1102	1643	975	1643	881	1642	780	1642	685	1644	589	—	—	—	—
	71	1588	1173	1589	1045	1589	949	1590	853	1588	752	1588	653	—	—	—	—
	67	1493	1342	1484	1188	1485	1090	1486	991	1486	893	1486	795	1485	693	1486	594
	62	1453	1453	1398	1398	1375	1293	1367	1179	1365	1070	1365	969	1365	868	1365	768
34000	75	1716	1059	1717	928	1717	830	1715	724	1716	623	—	—	—	—	—	—
	73	1660	1133	1661	1000	1661	900	1661	800	1660	695	1661	594	—	—	—	—
	71	1605	1208	1606	1073	1606	972	1607	871	1605	765	1605	661	—	—	—	—
	67	1513	1389	1501	1224	1502	1120	1502	1017	1503	913	1503	810	1501	703	1502	598
	62	1483	1484	1426	1426	1395	1340	1384	1215	1380	1100	1381	994	1381	888	1381	782
36000	75	1733	1085	1733	948	1733	845	1731	735	1732	629	—	—	—	—	—	—
	73	1676	1163	1677	1023	1677	919	1677	814	1675	703	1677	597	—	—	—	—
	71	1621	1242	1622	1100	1622	994	1623	888	1620	777	1621	671	—	—	—	—
	67	1532	1439	1516	1259	1517	1150	1518	1041	1518	933	1518	825	1516	712	1517	603
	62	1512	1512	1453	1453	1415	1387	1401	1258	1395	1130	1395	1018	1395	907	1395	795
38000	75	1748	1111	1748	967	1748	860	1746	745	1746	634	—	—	—	—	—	—
	73	1691	1192	1692	1046	1692	937	1691	828	1690	712	1691	601	—	—	—	—
	71	1635	1275	1636	1127	1637	1016	1637	905	1636	795	1635	678	—	—	—	—
	67	1552	1490	1535	1307	1531	1180	1531	1066	1532	952	1531	839	1529	721	1530	606
	62	1539	1539	1478	1478	1435	1429	1415	1294	1408	1158	1408	1041	1408	925	1408	808
40000	75	1761	1135	1762	986	1762	874	1759	754	1759	639	—	—	—	—	—	—
	73	1704	1220	1705	1068	1705	954	1705	841	1703	720	1704	604	—	—	—	—
	71	1649	1307	1650	1153	1650	1037	1650	922	1649	807	1647	685	—	—	—	—
	67	1571	1540	1548	1342	1543	1208	1544	1089	1544	971	1544	853	1542	730	1542	610
	62	1564	1564	1502	1502	1457	1457	1430	1335	1419	1187	1420	1064	1420	943	1419	821
42000	75	1774	1160	1774	1004	1774	888	1771	763	1771	643	—	—	—	—	—	—
	73	1717	1248	1717	1090	1718	971	1717	853	1714	728	1715	608	—	—	—	—
	71	1661	1339	1662	1178	1662	1057	1662	937	1661	818	1659	692	—	—	—	—
	67	1592	1586	1562	1381	1555	1236	1556	1113	1556	989	1555	866	1553	739	1553	613
	62	1588	1588	1524	1524	1477	1478	1444	1374	1432	1221	1431	1087	1431	960	1430	833
44000	75	1786	1183	1786	1022	1785	901	1783	772	1782	648	—	—	—	—	—	—
	73	1728	1276	1729	1111	1729	988	1728	866	1725	736	1726	611	—	—	—	—
	71	1672	1370	1673	1203	1673	1078	1673	953	1672	829	1670	698	—	—	—	—
	67	1614	1614	1576	1422	1566	1264	1566	1135	1566	1007	1566	879	1563	747	1564	617
	62	1610	1610	1545	1545	1497	1497	1458	1411	1444	1252	1441	1109	1441	977	1440	845
46000	75	1796	1207	1797	1039	1796	914	1793	781	1793	652	—	—	—	—	—	—
	73	1738	1303	1739	1132	1739	1004	1738	878	1736	743	1736	614	—	—	—	—
	71	1688	1421	1683	1227	1683	1097	1683	968	1682	840	1680	704	—	—	—	—
	67	1634	1634	1589	1465	1576	1291	1576	1157	1576	1024	1575	892	1573	755	1573	620
	62	1631	1631	1564	1565	1516	1516	1472	1448	1454	1280	1450	1131	1450	994	1449	857

* Rated performance is at sea level. Cooling capacities are gross cooling capacity.

Cooling Performance Data – 130 Ton Model (cont'd.)

TABLE 20 – COOLING PERFORMANCE DATA* – 130 TON MODEL (cont'd)

105° AIR ON CONDENSER COIL

CFM	ENTERING WB (°F)	CAPACITY (mbh) AT ENTERING DRY BULB (°F)															
		90		86		83		80		77		74		71		68	
		TMBH	SMBH	TMBH	SMBH	TMBH	SMBH	TMBH	SMBH	TMBH	SMBH	TMBH	SMBH	TMBH	SMBH	TMBH	SMBH
26000	75	1565	920	1566	816	1565	731	1566	654	1567	573	—	—	—	—	—	—
	73	1513	978	1513	872	1514	793	1513	709	1513	626	1516	549	—	—	—	—
	71	1461	1037	1462	929	1463	849	1464	769	1463	685	1463	603	—	—	—	—
	67	1366	1163	1364	1047	1365	965	1366	883	1366	802	1367	720	1366	635	1367	552
	62	1302	1302	1264	1218	1255	1122	1251	1030	1252	946	1252	863	1253	779	1253	696
28000	75	1589	950	1590	838	1588	749	1589	665	1590	580	—	—	—	—	—	—
	73	1536	1011	1537	898	1537	814	1536	724	1537	640	1538	555	—	—	—	—
	71	1484	1074	1485	960	1486	874	1486	789	1485	699	1485	611	—	—	—	—
	67	1390	1213	1386	1086	1387	998	1387	911	1388	824	1388	737	1387	646	1388	558
	62	1339	1339	1291	1274	1279	1172	1272	1068	1272	979	1273	890	1273	800	1273	711
30000	75	1610	978	1610	860	1611	772	1609	677	1610	586	—	—	—	—	—	—
	73	1556	1043	1557	924	1558	834	1556	739	1556	650	1558	559	—	—	—	—
	71	1504	1110	1505	989	1506	898	1506	808	1504	713	1504	619	—	—	—	—
	67	1413	1265	1405	1123	1406	1030	1407	938	1407	845	1407	753	1406	657	1407	563
	62	1373	1373	1321	1321	1300	1221	1293	1113	1291	1011	1291	916	1291	821	1291	726
32000	75	1628	1005	1629	881	1629	788	1627	688	1628	592	—	—	—	—	—	—
	73	1575	1074	1575	948	1576	854	1574	753	1574	659	1576	564	—	—	—	—
	71	1522	1145	1523	1017	1524	922	1524	826	1522	726	1522	627	—	—	—	—
	67	1433	1314	1423	1160	1423	1061	1424	964	1424	866	1424	768	1423	666	1424	568
	62	1405	1405	1350	1350	1320	1268	1310	1151	1307	1041	1307	941	1307	841	1307	740
34000	75	1645	1032	1646	901	1646	803	1644	698	1644	597	—	—	—	—	—	—
	73	1591	1105	1592	972	1592	873	1592	774	1590	668	1591	568	—	—	—	—
	71	1539	1180	1539	1045	1540	944	1540	844	1538	738	1538	638	—	—	—	—
	67	1453	1365	1438	1195	1439	1092	1439	989	1440	886	1439	783	1438	676	1439	572
	62	1434	1434	1378	1378	1340	1314	1327	1193	1321	1071	1322	965	1322	860	1321	754
36000	75	1452	984	1451	843	1451	741	1449	635	1448	531	—	—	—	—	—	—
	73	1606	1135	1607	995	1607	891	1606	787	1605	677	1606	571	—	—	—	—
	71	1553	1214	1554	1072	1554	966	1554	861	1553	752	1552	645	—	—	—	—
	67	1473	1416	1457	1243	1453	1122	1453	1013	1454	905	1453	797	1451	685	1452	576
	62	1461	1462	1403	1403	1361	1357	1342	1229	1335	1101	1335	989	1335	878	1334	767
38000	75	1464	1013	1462	861	1462	755	1460	644	1459	535	—	—	—	—	—	—
	73	1620	1164	1620	1018	1621	909	1620	801	1618	685	1619	575	—	—	—	—
	71	1566	1246	1567	1098	1568	988	1567	878	1567	768	1565	652	—	—	—	—
	67	1493	1466	1470	1278	1465	1151	1466	1037	1466	924	1466	811	1464	694	1464	579
	62	1487	1487	1427	1427	1384	1384	1357	1270	1347	1129	1347	1013	1347	896	1346	780
40000	75	1475	1037	1472	879	1472	768	1469	653	1468	540	—	—	—	—	—	—
	73	1632	1192	1633	1040	1633	926	1632	813	1630	693	1631	578	—	—	—	—
	71	1579	1278	1579	1124	1580	1009	1579	894	1578	779	1577	658	—	—	—	—
	67	1514	1512	1485	1320	1477	1179	1478	1061	1478	943	1477	825	1475	703	1475	583
	62	1511	1511	1450	1450	1405	1405	1371	1309	1360	1166	1358	1035	1358	914	1357	792
42000	75	1485	1065	1482	896	1481	781	1478	662	1477	544	—	—	—	—	—	—
	73	1643	1219	1644	1061	1644	943	1643	826	1641	701	1642	581	—	—	—	—
	71	1590	1310	1590	1149	1591	1029	1591	909	1589	790	1587	665	—	—	—	—
	67	1536	1536	1498	1358	1488	1207	1488	1084	1488	961	1488	838	1485	711	1486	586
	62	1534	1534	1471	1471	1425	1425	1386	1348	1371	1195	1368	1058	1368	931	1367	804
44000	75	1494	1088	1490	913	1489	794	1487	670	1485	548	—	—	—	—	—	—
	73	1654	1247	1655	1083	1655	960	1653	838	1651	709	1652	584	—	—	—	—
	71	1606	1360	1601	1174	1601	1049	1601	925	1599	801	1597	671	—	—	—	—
	67	1557	1557	1512	1401	1498	1235	1498	1106	1498	978	1497	851	1495	719	1495	589
	62	1555	1555	1491	1491	1443	1443	1400	1384	1381	1223	1377	1080	1377	948	1376	816
46000	75	1503	1114	1498	930	1497	806	1494	678	1492	552	—	—	—	—	—	—
	73	1463	1200	1452	1035	1449	895	1448	770	1446	641	1444	513	—	—	—	—
	71	1616	1393	1610	1198	1610	1069	1610	940	1609	811	1607	677	—	—	—	—
	67	1577	1577	1525	1442	1508	1266	1507	1128	1507	996	1506	863	1503	727	1504	592
	62	1575	1575	1509	1509	1461	1461	1416	1415	1392	1258	1386	1101	1386	964	1384	828

* Rated performance is at sea level. Cooling capacities are gross cooling capacity.

TABLE 20 – COOLING PERFORMANCE DATA* – 130 TON MODEL (cont'd)

95° AIR ON CONDENSER COIL

CFM	ENTERING WB (°F)	CAPACITY (mbh) AT ENTERING DRY BULB (°F)															
		90		86		83		80		77		74		71		68	
		TMBH	SMBH	TMBH	SMBH	TMBH	SMBH	TMBH	SMBH	TMBH	SMBH	TMBH	SMBH	TMBH	SMBH	TMBH	SMBH
26000	75	940	677	940	576	940	500	939	425	937	347	—	—	—	—	—	—
	73	1092	814	1091	703	1091	626	1090	547	1089	470	1089	390	—	—	—	—
	71	1059	879	1053	759	1054	680	1054	602	1053	523	1052	443	—	—	—	—
	67	1164	1049	1149	955	1146	870	1145	785	1145	704	1145	623	1144	541	1144	459
	62	1129	1129	1087	1073	1070	1000	1057	927	1051	852	1049	766	1049	682	1048	599
28000	75	948	702	949	595	948	515	947	435	945	352	—	—	—	—	—	—
	73	1107	850	1103	727	1104	644	1103	560	1102	478	1101	394	—	—	—	—
	71	1074	919	1068	793	1066	703	1066	620	1065	535	1064	450	—	—	—	—
	67	1185	1088	1169	989	1163	903	1161	813	1161	725	1161	639	1160	551	1160	464
	62	1159	1159	1113	1112	1091	1039	1076	960	1067	884	1064	793	1064	701	1063	613
30000	75	956	727	956	613	955	528	954	444	951	356	—	—	—	—	—	—
	73	930	813	924	675	924	588	923	502	921	417	919	328	—	—	—	—
	71	1089	956	1079	821	1077	725	1077	636	1076	547	1074	456	—	—	—	—
	67	1059	1020	1028	944	1012	871	1007	769	1005	672	1005	582	1003	491	1002	399
	62	1187	1187	1138	1138	1110	1076	1094	992	1082	914	1078	818	1077	721	1076	627
32000	75	966	766	963	631	962	541	960	452	958	360	—	—	—	—	—	—
	73	940	850	930	696	930	605	929	514	927	424	925	330	—	—	—	—
	71	1105	990	1091	853	1087	746	1087	653	1085	558	1084	463	—	—	—	—
	67	1076	1048	1044	966	1024	902	1017	797	1015	691	1014	596	1012	499	1011	402
	62	1069	1069	1162	1162	1128	1111	1109	1023	1096	939	1090	843	1089	739	1088	640
34000	75	972	791	969	649	968	554	966	460	963	364	—	—	—	—	—	—
	73	949	886	936	718	936	622	935	526	933	431	930	333	—	—	—	—
	71	1120	1012	1101	884	1096	767	1096	669	1094	569	1093	471	—	—	—	—
	67	1093	1074	1059	991	1037	932	1026	821	1023	709	1022	609	1021	507	1019	405
	62	1089	1089	1184	1184	1147	1145	1124	1054	1109	962	1102	868	1100	759	1098	653
36000	75	980	827	974	666	973	567	971	469	968	367	—	—	—	—	—	—
	73	958	919	944	752	941	638	940	537	938	437	934	335	—	—	—	—
	71	954	954	920	848	912	721	909	608	908	506	905	406	—	—	—	—
	67	1109	1100	1072	1012	1049	949	1035	848	1031	727	1030	621	1028	515	1026	408
	62	1107	1107	1058	1058	1166	1166	1138	1085	1121	985	1112	891	1109	777	1108	665
38000	75	986	851	979	683	978	579	976	476	972	371	—	—	—	—	—	—
	73	968	954	949	773	946	653	945	548	942	444	939	337	—	—	—	—
	71	967	967	927	873	917	742	914	622	912	516	910	411	—	—	—	—
	67	1125	1124	1085	1034	1060	966	1044	874	1039	750	1036	634	1034	522	1032	410
	62	1123	1123	1073	1073	1184	1184	1151	1114	1133	1013	1122	914	1118	794	1117	677
40000	75	993	885	983	699	982	591	980	484	976	374	—	—	—	—	—	—
	73	979	979	956	804	950	668	949	559	947	450	942	339	—	—	—	—
	71	979	979	935	907	922	761	918	637	916	526	914	416	—	—	—	—
	67	1140	1140	1097	1053	1071	983	1052	899	1045	768	1043	646	1040	530	1038	413
	62	1139	1139	1088	1088	1050	1050	1164	1144	1143	1035	1131	936	1126	811	1124	689
42000	75	1000	917	987	715	986	603	984	491	980	378	—	—	—	—	—	—
	73	990	990	961	826	954	683	953	569	950	456	946	341	—	—	—	—
	71	989	989	942	931	928	790	922	650	920	535	917	421	—	—	—	—
	67	1154	1154	1108	1074	1080	998	1059	922	1051	785	1048	658	1046	537	1043	415
	62	1153	1153	1101	1101	1063	1063	1177	1171	1153	1059	1139	955	1134	829	1132	700
44000	75	1005	940	991	731	990	614	987	499	983	381	—	—	—	—	—	—
	73	1000	1000	966	855	958	698	956	580	954	463	949	343	—	—	—	—
	71	1000	1000	952	952	932	809	925	664	924	544	920	425	—	—	—	—
	67	999	999	1119	1094	1091	1018	1067	945	1057	806	1053	669	1051	544	1048	418
	62	998	998	1114	1114	1075	1075	1037	1037	1163	1083	1147	971	1141	846	1138	711
46000	75	1012	969	995	751	993	625	991	506	986	384	—	—	—	—	—	—
	73	1009	1009	971	875	961	712	959	590	957	468	952	344	—	—	—	—
	71	1009	1009	961	961	937	837	928	677	927	553	923	430	—	—	—	—
	67	1008	1008	1129	1113	1099	1032	1074	960	1062	823	1058	681	1056	550	1052	420
	62	1008	1008	1126	1126	1086	1086	1047	1047	1172	1108	1155	988	1147	863	1144	722

* Rated performance is at sea level. Cooling capacities are gross cooling capacity.

Heating Performance Data – Gas/Electric Heat

GAS HEATING

TABLE 21 – GAS HEAT PERFORMANCE DATA

Unit	Gas Input Capacity (Btu/hr x 1000)	Maximum Output Capacity (Btu/hr x 1000)	Airflow	Temp. Rise (°F)
			Minimum	
50-65	375	300	6,950	10-40
	750	600	11,150	20-50
70-85	375	300	7,500	10-40
	750	600	11,150	20-50
	1125	900	15,150	25-55
90-105	375	300	6,950	10-40
	750	600	11,150	20-50
	1125	900	15,150	25-55
106-130	1125	900	19350	43

NOTE:

Gas valve rated for .5 PSIG. If gas pressure greater than .5 PSIG then a gas pressure regulator is required.

Minimum gas pressure is 3.5 iwg.

ELECTRIC HEATING

TABLE 17 – ELECTRIC HEAT PERFORMANCE DATA

UNIT	SIZE (KW)	HEAT CAPACITY (MBH)	AIR FLOW MIN (CFM)	MAX TEMP RISE (°F)
50-65 TON	40	137	8,000	16
	80	273	10,000	25
	108	369	12,000	28
	150	512	14,000	34
70-85 TON	80	273	10,000	25
	108	369	12,000	28
	150	512	14,000	34
	200	683	15,000	42
90-105 TON	80	273	10,000	25
	108	369	12,000	28
	150	512	14,000	34
	200	683	15,000	42
	250	854	16,000	49
160-130 TON	80	273	15,000	22
	108	369	15,000	28
	150	512	15,000	36
	200	683	15,000	47
	250	854	15,000	44

This page intentionally left blank

Supply Fan Data

TABLE 23 – YPAL050-065 : 25X22 FORWARD CURVED FAN

TOTAL STATIC PRESSURE (inches of water column)												
CFM STD. AIR	1.0		2.0		3.0		4.0		5.0		6.0	
	BHP	RPM	BHP	RPM	BHP	RPM	BHP	RPM	BHP	RPM	BHP	RPM
12000	3.7	418	6.2	567								
14000	4.9	433	7.7	574	10.9	699						
16000	6.3	449	9.6	586	12.8	696	16.7	811	21.9	940		
18000	8.1	469	11.7	597	15.4	710	18.9	802	23.4	905		
20000			14.1	612	18.2	719	22.2	814	26.2	896	31.1	987
22000			16.9	629	21.3	730	26.0	826	30.3	907	34.6	981
24000			20.3	648	24.9	746	29.9	835	34.9	921		
26000					29.0	763	34.2	848	39.7	929		

TABLE 24 – YPAL050-065 : 25" AIRFOIL FAN

TOTAL STATIC PRESSURE (inches of water column)												
CFM STD. AIR	1.0		2.0		3.0		4.0		5.0		6.0	
	BHP	RPM	BHP	RPM	BHP	RPM	BHP	RPM	BHP	RPM	BHP	RPM
12000					7.9	1191	10.6	1326	13.4	1468	16.3	1591
14000			6.9	1133	9.6	1260	12.3	1379	15.4	1493	18.6	1615
16000			8.9	1213	11.5	1341	14.5	1450	17.7	1555	21.2	1655
18000			11.1	1300	13.9	1423	17.1	1528	20.5	1626	24.0	1719
20000			13.3	1392	17.0	1502	20.0	1611	23.7	1703	27.4	1791
22000			16.0	1487	20.2	1589	23.9	1690	27.2	1787	31.3	1869
24000			19.2	1584	23.6	1682	28.1	1773	31.8	1867	35.5	1953
26000					27.5	1777	32.4	1862	37.1	1946		

TABLE 25 – YPAL070-085 : 28X25 FORWARD CURVED FAN

TOTAL STATIC PRESSURE (inches of water column)												
CFM STD. AIR	1.0		2.0		3.0		4.0		5.0		6.0	
	BHP	RPM	BHP	RPM	BHP	RPM	BHP	RPM	BHP	RPM	BHP	RPM
18000			10.0	513	13.9	616						
20000			11.7	520	15.9	619	20.8	717				
22000			13.6	527	18.3	629	22.9	712	28.9	808		
24000			15.8	537	20.9	637	25.9	720	31.1	795		
26000			18.3	549	23.6	643	29.1	729	34.5	801		
28000			21.2	562	26.6	651	32.6	736	38.5	810		
30000			24.2	574	30.1	662	36.3	742	42.8	819		
32000			27.4	585	34.0	674	40.3	750	47.2	825		
34000			30.9	597	38.2	686	44.8	760				

NOTE: For performance at operating points not included in these tables, consult your local YORK representative

TABLE 26 – YPAL090-105 : 28X28 FORWARD CURVED FAN

CFM STD. AIR	TOTAL STATIC PRESSURE (inches of water column)											
	1.0		2.0		3.0		4.0		5.0		6.0	
	BHP	RPM	BHP	RPM	BHP	RPM	BHP	RPM	BHP	RPM	BHP	RPM
20000			12.1	526	16.9	629	24.8	764				
22000			14.1	534	18.9	631	25.1	731				
24000			16.3	543	21.5	641	27.1	726	34.8	825		
26000			18.6	552	24.5	651	30.1	732	36.7	812		
28000			21.2	562	27.5	659	33.7	741	39.9	814		
30000			24.2	574	30.9	668	37.6	751	44.1	823		
32000			27.5	587	34.5	676	41.7	760	48.7	832		
34000			31.1	601	38.5	687	46.1	768	53.7	842		
36000			35.0	615	42.7	698	50.7	776	58.8	850		

TABLE 27 – YPAL070-105 : 32" AIRFOIL FAN

CFM STD. AIR	TOTAL STATIC PRESSURE (inches of water column)											
	1.0		2.0		3.0		4.0		5.0		6.0	
	BHP	RPM	BHP	RPM	BHP	RPM	BHP	RPM	BHP	RPM	BHP	RPM
18000					11.6	923	15.5	1036	19.5	1145	23.8	1236
20000					13.0	954	17.2	1055	21.6	1157	26.0	1256
22000					14.7	991	18.9	1083	23.7	1176	28.5	1269
24000			12.4	936	16.5	1030	21.0	1119	25.7	1202	31.0	1287
26000			14.4	978	18.5	1074	23.3	1155	28.2	1235	33.4	1313
28000			16.6	1021	20.9	1117	25.7	1195	31.1	1272	36.3	1344
30000			18.9	1067	23.7	1159	28.5	1240	34.0	1310	39.7	1381
32000			21.3	1114	26.8	1201	31.6	1283	37.1	1352	43.2	1418
YPAL090-095 Only												
34000			23.8	1161	30.0	1245	35.2	1325	40.6	1396	46.7	1458
36000			26.6	1209	33.3	1289	39.2	1366	44.6	1438	50.6	1501

NOTE: For performance at operating points not included in these tables, consult your local YORK representative.

TABLE 28 – YPAL0106-130 : 40" AIRFOIL FAN

CFM STD. AIR	TOTAL STATIC PRESSURE (inches of water column)									
	1.0		2.0		3.0		4.0		5.0	
	BHP	RPM	BHP	RPM	BHP	RPM	BHP	RPM	BHP	RPM
24000			10.5	615	16	715	22.1	812		
26000			11.6	634	17.2	729	23.5	820		
28000			12.7	653	18.4	742	24.9	828		
30000			14.0	675	19.9	760	26.5	841		
32000	9.2	607	15.3	696	21.4	777	28.1	854		
34000			16.8	719	23.2	797	30.0	871		
36000			18.2	742	24.9	817	31.9	888		
38000			19.9	767	26.9	839	34.1	908		
40000			21.5	791	28.9	861	36.3	927	44.2	991
42000			23.2	817	31.2	885	38.9	949	47.0	1011
44000			24.9	842	33.4	908	41.5	970	49.7	1030
46000			26.7	869	35.8	932	44.3	993	52.8	1050

Component Static Pressure Drops

TABLE 29 – COMPONENT STATIC PRESSURE DROPS (INCHES OF WATER COLUMN)

Size	Air Flow CFM Std. Air	Evaporator Coils		Return Air Opening			Filters			
		Wet	Dry	Bottom	front	side	2" throwaway	2" cleanable	2" pleated	2" carbon
50	10000	0.10	0.07	0.08	0.05	---	0.05	0.01	0.04	0.08
	12000	0.13	0.10	0.10	0.06	---	0.07	0.02	0.06	0.11
	14000	0.17	0.12	0.11	0.07	---	0.09	0.03	0.07	0.14
	16000	0.21	0.15	0.14	0.09	---	0.11	0.04	0.09	0.16
	17500	0.24	0.18	0.16	0.10	---	0.12	0.05	0.10	0.19
	18000	0.25	0.19	0.17	0.11	---	0.13	0.05	0.10	0.19
	20000	0.29	0.22	0.20	0.13	---	0.15	0.06	0.12	0.22
	21000	0.32	0.24	0.23	0.14	---	0.16	0.07	0.13	0.24
	22000	0.34	0.26	0.25	0.16	---	0.17	0.08	0.14	0.26
24000	0.39	0.30	0.31	0.19	---	0.19	0.09	0.16	0.29	
55	12000	0.17	0.13	0.10	0.06	---	0.07	0.02	0.06	0.11
	14000	0.22	0.17	0.11	0.07	---	0.09	0.03	0.07	0.14
	16000	0.27	0.21	0.14	0.09	---	0.11	0.04	0.09	0.16
	18000	0.32	0.25	0.17	0.11	---	0.13	0.05	0.10	0.19
	19250	0.36	0.28	0.19	0.12	---	0.14	0.06	0.12	0.21
	20000	0.38	0.30	0.20	0.13	---	0.15	0.06	0.12	0.22
	22000	0.44	0.35	0.25	0.16	---	0.17	0.08	0.14	0.26
24000	0.50	0.40	0.31	0.19	---	0.19	0.09	0.16	0.29	
60	14000	0.40	0.25	0.11	0.07	---	0.09	0.03	0.07	0.14
	16000	0.48	0.31	0.14	0.09	---	0.11	0.04	0.09	0.16
	18000	0.56	0.37	0.17	0.11	---	0.13	0.05	0.10	0.19
	20000	0.65	0.44	0.20	0.13	---	0.15	0.06	0.12	0.22
	21000	0.70	0.47	0.23	0.14	---	0.16	0.07	0.13	0.24
	22000	0.74	0.51	0.25	0.16	---	0.17	0.08	0.14	0.26
	24000	0.84	0.58	0.31	0.19	---	0.19	0.09	0.16	0.29
	26000	0.93	0.66	0.38	0.24	---	0.21	0.11	0.19	0.32
27000	0.98	0.70	0.42	0.26	---	0.23	0.12	0.20	0.34	
65	14000	0.37	0.25	0.11	0.07	---	0.09	0.03	0.07	0.14
	16000	0.45	0.32	0.14	0.09	---	0.11	0.04	0.09	0.16
	18000	0.53	0.38	0.17	0.11	---	0.13	0.05	0.10	0.19
	20000	0.62	0.45	0.20	0.13	---	0.15	0.06	0.12	0.22
	21000	0.66	0.49	0.23	0.14	---	0.16	0.07	0.13	0.24
	22000	0.71	0.53	0.25	0.16	---	0.17	0.08	0.14	0.26
	24000	0.80	0.61	0.31	0.19	---	0.19	0.09	0.16	0.29
	26000	0.90	0.69	0.38	0.24	---	0.21	0.11	0.19	0.32
27000	0.95	0.73	0.42	0.26	---	0.23	0.12	0.20	0.34	
70	14000	0.20	0.12	0.06	0.03	0.07	0.06	0.02	0.05	0.10
	16000	0.24	0.15	0.07	0.03	0.08	0.08	0.02	0.06	0.12
	18000	0.29	0.18	0.08	0.04	0.09	0.09	0.03	0.07	0.14
	20000	0.33	0.22	0.09	0.05	0.11	0.11	0.04	0.09	0.16
	22000	0.38	0.26	0.11	0.05	0.13	0.12	0.05	0.10	0.19
	24000	0.44	0.30	0.13	0.06	0.15	0.14	0.06	0.12	0.21
	26000	0.49	0.34	0.15	0.08	0.18	0.15	0.07	0.13	0.24
	28000	0.55	0.38	0.18	0.09	0.21	0.17	0.08	0.15	0.26
30000	0.61	0.43	0.21	0.10	0.24	0.19	0.09	0.16	0.29	
75	14000	0.33	0.20	0.06	0.03	0.07	0.06	0.02	0.05	0.10
	16000	0.39	0.25	0.07	0.03	0.08	0.08	0.02	0.06	0.12
	18000	0.46	0.30	0.08	0.04	0.09	0.09	0.03	0.07	0.14
	20000	0.53	0.35	0.09	0.05	0.11	0.11	0.04	0.09	0.16
	22000	0.61	0.41	0.11	0.05	0.13	0.12	0.05	0.10	0.19
	24000	0.68	0.47	0.13	0.06	0.15	0.14	0.06	0.12	0.21
	26000	0.76	0.54	0.15	0.08	0.18	0.15	0.07	0.13	0.24
	28000	0.84	0.61	0.18	0.09	0.21	0.17	0.08	0.15	0.26
30000	0.92	0.68	0.21	0.10	0.24	0.19	0.09	0.16	0.29	

NOTES: * Includes 2" pleated filters. ** Power exhaust pressure drops are for sizing supply fan.

1. Return air opening pressure drop does not include an exhaust fan. Use the value in the Powered Exhaust column to determine return air pressure drop attributed to the exhaust fan assembly.
2. Front return is not available with barometric relief, exhaust fans or return fans.
3. Pressure drop for 12-inch rigid filter media includes a 2-inch prefilter.

Rigid Filter Rack, No Media	Filters			Outside Air Dampers	Powered Exhaust
	12" Rigid, 65%*	12" Rigid, 95%*	12" Rigid, 95% (Final Filter Position)*		
0.09	0.21	0.30	0.24	0.17	0.01
0.12	0.28	0.38	0.30	0.21	0.01
0.15	0.34	0.46	0.37	0.25	0.02
0.18	0.42	0.55	0.43	0.31	0.03
0.20	0.47	0.62	0.48	0.36	0.03
0.21	0.49	0.65	0.50	0.38	0.03
0.25	0.58	0.74	0.57	0.46	0.04
0.27	0.62	0.79	0.60	0.51	0.04
0.28	0.66	0.84	0.64	0.57	0.05
0.32	0.75	0.95	0.71	0.69	0.06
0.12	0.28	0.38	0.30	0.21	0.01
0.15	0.34	0.46	0.37	0.25	0.02
0.18	0.42	0.55	0.43	0.31	0.03
0.21	0.49	0.65	0.50	0.38	0.03
0.23	0.54	0.71	0.54	0.43	0.04
0.25	0.58	0.74	0.57	0.46	0.04
0.28	0.66	0.84	0.64	0.57	0.05
0.32	0.75	0.95	0.71	0.69	0.06
0.15	0.34	0.46	0.37	0.25	0.02
0.18	0.42	0.55	0.43	0.31	0.03
0.21	0.49	0.65	0.50	0.38	0.03
0.25	0.58	0.74	0.57	0.46	0.04
0.27	0.62	0.79	0.60	0.51	0.04
0.28	0.66	0.84	0.64	0.57	0.05
0.32	0.75	0.95	0.71	0.69	0.06
0.36	0.84	1.06	0.79	0.84	0.07
0.38	0.89	1.11	0.82	0.93	0.07
0.15	0.34	0.46	0.37	0.25	0.02
0.18	0.42	0.55	0.43	0.31	0.03
0.21	0.49	0.65	0.50	0.38	0.03
0.25	0.58	0.74	0.57	0.46	0.04
0.27	0.62	0.79	0.60	0.51	0.04
0.28	0.66	0.84	0.64	0.57	0.05
0.32	0.75	0.95	0.71	0.69	0.06
0.36	0.84	1.06	0.79	0.84	0.07
0.38	0.89	1.11	0.82	0.93	0.07
0.10	0.24	0.33	0.26	0.13	0.01
0.12	0.29	0.39	0.31	0.15	0.01
0.14	0.34	0.46	0.36	0.18	0.02
0.17	0.40	0.53	0.41	0.21	0.02
0.19	0.45	0.60	0.46	0.25	0.02
0.22	0.51	0.67	0.51	0.29	0.03
0.25	0.58	0.75	0.56	0.34	0.03
0.28	0.64	0.82	0.61	0.40	0.04
0.31	0.71	0.90	0.67	0.47	0.04
0.10	0.24	0.33	0.26	0.13	0.01
0.12	0.29	0.39	0.31	0.15	0.01
0.14	0.34	0.46	0.36	0.18	0.02
0.17	0.40	0.53	0.41	0.21	0.02
0.19	0.45	0.60	0.46	0.25	0.02
0.22	0.51	0.67	0.51	0.29	0.03
0.25	0.58	0.75	0.56	0.34	0.03
0.28	0.64	0.82	0.61	0.40	0.04
0.31	0.71	0.90	0.67	0.47	0.04

Component Static Pressure Drops (continued)

TABLE 29 – COMPONENT STATIC PRESSURE DROPS (INCHES OF WATER COLUMN) (CONT'D)

Size	Air Flow CFM Std. Air	Evaporator Coils		Return Air Opening			Filters			
		Wet	Dry	Bottom	front	side	2" throwaway	2" cleanable	2" pleated	2" carbon
80	16000	0.23	0.16	0.07	0.03	0.08	0.08	0.02	0.06	0.12
	18000	0.27	0.19	0.08	0.04	0.09	0.09	0.03	0.07	0.14
	20000	0.32	0.23	0.09	0.05	0.11	0.11	0.04	0.09	0.16
	22000	0.36	0.27	0.11	0.05	0.13	0.12	0.05	0.10	0.19
	24000	0.41	0.31	0.13	0.06	0.15	0.14	0.06	0.12	0.21
	26000	0.47	0.35	0.15	0.08	0.18	0.15	0.07	0.13	0.24
	28000	0.52	0.39	0.18	0.09	0.21	0.17	0.08	0.15	0.26
	30000	0.58	0.44	0.21	0.10	0.24	0.19	0.09	0.16	0.29
32000	0.63	0.49	0.24	0.12	0.29	0.21	0.10	0.18	0.32	
85	16000	0.32	0.21	0.07	0.03	0.08	0.08	0.02	0.06	0.12
	18000	0.38	0.25	0.08	0.04	0.09	0.09	0.03	0.07	0.14
	20000	0.44	0.30	0.09	0.05	0.11	0.11	0.04	0.09	0.16
	22000	0.51	0.35	0.11	0.05	0.13	0.12	0.05	0.10	0.19
	24000	0.58	0.40	0.13	0.06	0.15	0.14	0.06	0.12	0.21
	26000	0.65	0.46	0.15	0.08	0.18	0.15	0.07	0.13	0.24
	28000	0.72	0.52	0.18	0.09	0.21	0.17	0.08	0.15	0.26
	30000	0.80	0.58	0.21	0.10	0.24	0.19	0.09	0.16	0.29
32000	0.88	0.65	0.24	0.12	0.29	0.21	0.10	0.18	0.32	
90	18000	0.34	0.23	0.08	0.05	0.09	0.07	0.02	0.06	0.11
	20000	0.40	0.27	0.09	0.06	0.10	0.08	0.03	0.06	0.13
	22000	0.46	0.32	0.11	0.07	0.11	0.09	0.03	0.08	0.14
	24000	0.53	0.36	0.12	0.08	0.13	0.11	0.04	0.09	0.16
	26000	0.60	0.41	0.14	0.09	0.15	0.12	0.05	0.10	0.18
	28000	0.66	0.47	0.16	0.10	0.17	0.13	0.05	0.11	0.20
	30000	0.74	0.52	0.19	0.12	0.19	0.15	0.06	0.12	0.22
	32000	0.81	0.58	0.22	0.13	0.22	0.16	0.07	0.14	0.24
34000	0.89	0.64	0.25	0.15	0.26	0.18	0.08	0.15	0.27	
36000	0.97	0.70	0.29	0.18	0.29	0.19	0.09	0.16	0.29	
95	18000	0.46	0.29	0.08	0.05	0.09	0.07	0.02	0.06	0.11
	20000	0.53	0.34	0.09	0.06	0.10	0.08	0.03	0.06	0.13
	22000	0.61	0.40	0.11	0.07	0.11	0.09	0.03	0.08	0.14
	24000	0.70	0.46	0.12	0.08	0.13	0.11	0.04	0.09	0.16
	26000	0.78	0.52	0.14	0.09	0.15	0.12	0.05	0.10	0.18
	28000	0.87	0.58	0.16	0.10	0.17	0.13	0.05	0.11	0.20
	30000	0.97	0.65	0.19	0.12	0.19	0.15	0.06	0.12	0.22
	32000	1.06	0.73	0.22	0.13	0.22	0.16	0.07	0.14	0.24
34000	1.16	0.80	0.25	0.15	0.26	0.18	0.08	0.15	0.27	
36000	1.26	0.88	0.29	0.18	0.29	0.19	0.09	0.16	0.29	
105	18000	0.46	0.29	0.08	0.05	0.09	0.07	0.02	0.06	0.11
	20000	0.53	0.34	0.09	0.06	0.10	0.08	0.03	0.06	0.13
	22000	0.61	0.40	0.11	0.07	0.11	0.09	0.03	0.08	0.14
	24000	0.70	0.46	0.12	0.08	0.13	0.11	0.04	0.09	0.16
	26000	0.78	0.52	0.14	0.09	0.15	0.12	0.05	0.10	0.18
	28000	0.87	0.58	0.16	0.10	0.17	0.13	0.05	0.11	0.20
	30000	0.97	0.65	0.19	0.12	0.19	0.15	0.06	0.12	0.22
	32000	1.06	0.73	0.22	0.13	0.22	0.16	0.07	0.14	0.24
34000	1.16	0.80	0.25	0.15	0.26	0.18	0.08	0.15	0.27	
36000	1.26	0.88	0.29	0.18	0.29	0.19	0.09	0.16	0.29	

NOTES: * Includes 2" pleated filters. ** Power exhaust pressure drops are for sizing supply fan.

1. Return air opening pressure drop does not include an exhaust fan. Use the value in the Powered Exhaust column to determine return air pressure drop attributed to the exhaust fan assembly.
2. Front return is not available with barometric relief, exhaust fans or return fans.
3. Pressure drop for 12-inch rigid filter media includes a 2-inch prefilter.

Rigid Filter Rack, No Media	Filters			Outside Air Dampers	Powered Exhaust
	12" Rigid, 65%*	12" Rigid, 95%*	12" Rigid, 95% (Final Filter Position)*		
0.12	0.29	0.39	0.31	0.15	0.01
0.14	0.34	0.46	0.36	0.18	0.02
0.17	0.40	0.53	0.41	0.21	0.02
0.19	0.45	0.60	0.46	0.25	0.02
0.22	0.51	0.67	0.51	0.29	0.03
0.25	0.58	0.75	0.56	0.34	0.03
0.28	0.64	0.82	0.61	0.40	0.04
0.31	0.71	0.90	0.67	0.47	0.04
0.34	0.78	0.98	0.72	0.55	0.05
0.12	0.29	0.39	0.31	0.15	0.01
0.14	0.34	0.46	0.36	0.18	0.02
0.17	0.40	0.53	0.41	0.21	0.02
0.19	0.45	0.60	0.46	0.25	0.02
0.22	0.51	0.67	0.51	0.29	0.03
0.25	0.58	0.75	0.56	0.34	0.03
0.28	0.64	0.82	0.61	0.40	0.04
0.31	0.71	0.90	0.67	0.47	0.04
0.34	0.78	0.98	0.72	0.55	0.05
0.07	0.29	0.40	0.31	0.18	0.01
0.08	0.34	0.46	0.36	0.21	0.01
0.09	0.39	0.52	0.40	0.24	0.02
0.11	0.45	0.59	0.45	0.27	0.02
0.12	0.50	0.65	0.49	0.32	0.02
0.13	0.56	0.72	0.54	0.36	0.03
0.15	0.61	0.79	0.59	0.42	0.03
0.16	0.67	0.86	0.64	0.48	0.03
0.18	0.74	0.93	0.69	0.55	0.04
0.19	0.80	1.01	0.74	0.64	0.04
0.07	0.29	0.40	0.31	0.18	0.01
0.08	0.34	0.46	0.36	0.21	0.01
0.09	0.39	0.52	0.40	0.24	0.02
0.11	0.45	0.59	0.45	0.27	0.02
0.12	0.50	0.65	0.49	0.32	0.02
0.13	0.56	0.72	0.54	0.36	0.03
0.15	0.61	0.79	0.59	0.42	0.03
0.16	0.67	0.86	0.64	0.48	0.03
0.18	0.74	0.93	0.69	0.55	0.04
0.19	0.80	1.01	0.74	0.64	0.04
0.07	0.29	0.40	0.31	0.18	0.01
0.08	0.34	0.46	0.36	0.21	0.01
0.09	0.39	0.52	0.40	0.24	0.02
0.11	0.45	0.59	0.45	0.27	0.02
0.12	0.50	0.65	0.49	0.32	0.02
0.13	0.56	0.72	0.54	0.36	0.03
0.15	0.61	0.79	0.59	0.42	0.03
0.16	0.67	0.86	0.64	0.48	0.03
0.18	0.74	0.93	0.69	0.55	0.04
0.19	0.80	1.01	0.74	0.64	0.04

Component Static Pressure Drops (continued)

TABLE 29 – COMPONENT STATIC PRESSURE DROPS (INCHES OF WATER COLUMN)

Size	Air Flow CFM Std. Air	Evaporator Coils Wet	Return Air Opening		Filters			
			Bottom	End	2" throwaway	2" cleanable	2" pleated	2" carbon
106- 130	24000	0.39	0.08	0.14	0.10	0.04	0.08	0.16
	26000	0.44	0.10	0.16	0.11	0.04	0.10	0.18
	28000	0.50	0.11	0.18	0.13	0.05	0.11	0.20
	30000	0.57	0.12	0.20	0.14	0.06	0.12	0.22
	32000	0.63	0.14	0.23	0.16	0.07	0.13	0.24
	34000	0.70	0.15	0.26	0.17	0.08	0.15	0.26
	36000	0.77	0.17	0.29	0.19	0.09	0.16	0.28
	38000	0.84	0.20	0.33	0.20	0.10	0.17	0.30
	40000	0.92	0.22	0.37	0.22	0.11	0.19	0.32
	42000	1.00	0.25	0.42	0.23	0.12	0.20	0.35
	44000	1.08	0.28	0.47	0.25	0.13	0.22	0.37
	46000	1.16	0.32	0.53	0.27	0.15	0.23	0.39

NOTES: *Includes 2" pleated filters. ** Power exhaust pressure drops are for sizing supply fan.

1. Return air opening pressure drop does not include an exhaust fan. Use the value in the Powered Exhaust column to determine return air pressure drop attributed to the exhaust fan assembly.
2. Front return is not available with barometric relief, exhaust fans or return fans.
3. Pressure drop for 12-inch rigid filter media includes a 2-inch prefilter.

Rigid Filter Rack, No Media	Filters		Outside Air Dampers	Powered Exhaust (use with bottom return)
	12" Rigid, 65%*	12" Rigid, 95%*		
0.12	0.34	0.46	0.11	0.12
0.14	0.38	0.51	0.13	0.14
0.16	0.43	0.56	0.14	0.15
0.17	0.47	0.62	0.16	0.17
0.19	0.52	0.67	0.18	0.20
0.21	0.56	0.73	0.20	0.22
0.23	0.61	0.79	0.23	0.25
0.25	0.66	0.84	0.26	0.28
0.27	0.71	0.90	0.29	0.32
0.30	0.76	0.96	0.33	0.36
0.32	0.82	1.03	0.37	0.40
0.34	0.87	1.09	0.42	0.46

Gas Heat Pressure Drops

TABLE 30 – GAS HEAT AIR PRESSURE DROPS

Size	Air Flow CFM Std. Air	Size (mbh)		
		375	750	1125
50	10000	0.12	0.25	—
	12000	0.15	0.30	—
	14000	0.17	0.35	—
	16000	0.20	0.40	—
	17500	0.22	0.44	—
	18000	0.22	0.45	—
	20000	0.25	0.50	—
	22000	0.27	0.55	—
	22500	0.28	0.56	—
55	12000	0.15	0.30	—
	14000	0.17	0.35	—
	16000	0.20	0.40	—
	18000	0.22	0.45	—
	19250	0.24	0.48	—
	20000	0.25	0.50	—
	22000	0.27	0.55	—
	24000	0.30	0.60	—
60	14000	0.17	0.35	—
	16000	0.20	0.40	—
	18000	0.22	0.45	—
	20000	0.25	0.50	—
	21000	0.26	0.52	—
	22000	0.27	0.55	—
	24000	0.30	0.60	—
	26000	0.32	0.65	—
65	14000	0.17	0.35	—
	16000	0.20	0.40	—
	18000	0.22	0.45	—
	20000	0.25	0.50	—
	21000	0.26	0.52	—
	22000	0.27	0.55	—
	24000	0.30	0.60	—
	26000	0.32	0.65	—
	27000	0.34	0.67	—
70	16000	0.16	0.32	0.48
	18000	0.18	0.36	0.54
	20000	0.20	0.40	0.60
	22000	0.22	0.44	0.66
	24000	0.24	0.48	0.72
	26000	0.26	0.52	0.78
	27000	0.27	0.54	0.81

Size	Air Flow CFM Std. Air	Size (mbh)		
		375	750	1125
75	16000	0.16	0.32	0.48
	18000	0.18	0.36	0.54
	20000	0.20	0.40	0.60
	22000	0.22	0.44	0.66
	24000	0.24	0.48	0.72
	26000	0.26	0.52	0.78
	27000	0.27	0.54	0.81
	80	18000	0.18	0.36
20000		0.20	0.40	0.60
22000		0.22	0.44	0.66
24000		0.24	0.48	0.72
26000		0.26	0.52	0.78
28000		0.28	0.56	0.84
30000		0.30	0.60	0.90
85	18000	0.18	0.36	0.54
	20000	0.20	0.40	0.60
	22000	0.22	0.44	0.66
	24000	0.24	0.48	0.72
	26000	0.26	0.52	0.78
	28000	0.28	0.56	0.84
	30000	0.30	0.60	0.90
90	20000	0.18	0.35	0.53
	22000	0.19	0.39	0.58
	24000	0.21	0.42	0.64
	26000	0.23	0.46	0.69
	28000	0.25	0.50	0.74
	30000	0.27	0.53	0.80
	31500	0.28	0.56	0.84
	32000	0.28	0.57	0.85
	34000	0.30	0.60	0.90
95 & 105	20000	0.18	0.35	0.53
	22000	0.19	0.39	0.58
	24000	0.21	0.42	0.64
	26000	0.23	0.46	0.69
	28000	0.25	0.50	0.74
	30000	0.27	0.53	0.80
	31500	0.28	0.56	0.84
	32000	0.28	0.57	0.85
	34000	0.30	0.60	0.90
36000	0.32	0.64	0.95	

TABLE 30 – GAS HEAT AIR PRESSURE DROPS (cont'd)

Size	Air Flow CFM Std. Air	Size (mbh)
		1125
106-130	20000	0.52
	22000	0.57
	24000	0.63
	26000	0.68
	28000	0.74
	30000	0.81
	31500	0.86
	32000	0.88
	34000	0.96
	36000	1.05
	38000	1.14
	40000	1.24
	42000	1.35
	44000	1.46
46000	1.59	

Electric Heat Pressure Drops

TABLE 31 – ELECTRIC HEATER SIZE AVAILABILITY BY UNIT SIZE

Model	40kW	80kW	108kW	150kW	200kW*	250kW*
YPAL050-065	X	X	X	X		
YPAL070-085		X	X	X	X	
YPAL090-105**			X	X	X	X
YPAL106-130		X	X	X	X	X

* 150-250kW electric heat not available in 200-230V configurations.

** For 208V YPAL105, contact YORK.

TABLE 32 – ELECTRIC HEAT AIR PRESSURE DROPS

Heating Stages							
	1	2	3	4	5	6	7
Voltage	Heating Capacity (kW)						
208V/3/60Hz			40 kW		80 kW		108 kW
240V/3/60Hz			40 kW		80 kW	108 kW	
380V/3/60Hz		34 kW	67 kW	91 kW	126 kW	168 kW	
415V/3/60HZ		40 kW	80 kW	108 kW	150 kW	200kW	
480V/3/60Hz		40 kW	80 & 108 kW	150 kW		200 kW	250kW
600V/3/60Hz	40 kW	80 kW	108 kW	150 kW	200 kW	250 kW	

Model	Air Flow CFM Std. Air	Electric Heater Air Pressure Drop (in w.c.)						
YPAL050-065	10000	0.01	0.01	0.02	0.03	0.03	0.04	0.05
	12000	0.01	0.02	0.03	0.04	0.05	0.06	0.07
	14000	0.02	0.03	0.04	0.05	0.07	0.08	0.09
	16000	0.02	0.04	0.05	0.07	0.09	0.10	0.12
	17500	0.02	0.04	0.06	0.08	0.10	0.12	0.14
	18000	0.02	0.05	0.07	0.09	0.11	0.13	0.15
	19250	0.03	0.05	0.08	0.10	0.12	0.15	0.17
	20000	0.03	0.06	0.08	0.11	0.13	0.16	0.18
	21000	0.03	0.06	0.09	0.12	0.15	0.17	0.20
	22000	0.04	0.07	0.10	0.13	0.16	0.19	0.22
	22500	0.04	0.07	0.10	0.14	0.17	0.20	0.23
	24000	0.04	0.08	0.12	0.15	0.19	0.23	0.27
YPAL070-085	26000	0.05	0.10	0.14	0.18	0.22	0.27	0.31
	27000	0.06	0.10	0.15	0.20	0.24	0.29	0.34
	16000	0.02	0.03	0.04	0.06	0.07	0.09	0.10
	18000	0.02	0.04	0.06	0.07	0.09	0.11	0.13
	20000	0.03	0.05	0.07	0.09	0.11	0.13	0.15
	22000	0.03	0.06	0.08	0.11	0.14	0.16	0.19
	24000	0.04	0.07	0.10	0.13	0.16	0.19	0.22
	26000	0.04	0.08	0.12	0.15	0.19	0.23	0.26
YPAL090-105	27000	0.05	0.09	0.13	0.16	0.20	0.24	0.28
	28000	0.05	0.09	0.13	0.18	0.22	0.26	0.30
	30000	0.06	0.11	0.15	0.20	0.25	0.30	0.35
	32000	0.07	0.12	0.18	0.23	0.29	0.34	0.40
	20000	0.02	0.04	0.05	0.07	0.09	0.10	0.12
	22000	0.02	0.04	0.06	0.08	0.10	0.12	0.14
	24000	0.03	0.05	0.08	0.10	0.12	0.15	0.17
	26000	0.03	0.06	0.09	0.12	0.15	0.17	0.20
	28000	0.04	0.07	0.10	0.14	0.17	0.20	0.23
	30000	0.04	0.08	0.12	0.16	0.19	0.23	0.27
31500	0.05	0.09	0.13	0.17	0.21	0.25	0.30	
32000	0.05	0.09	0.14	0.18	0.22	0.26	0.31	
34000	0.06	0.11	0.15	0.20	0.25	0.30	0.34	
36000	0.06	0.12	0.17	0.23	0.28	0.33	0.39	

TABLE 32 – ELECTRIC HEAT AIR PRESSURE DROPS (cont'd)

Heating Stages							
	1	2	3	4	5	6	7
Voltage	Heating Capacity (kW)						
208V/3/60Hz					80 kW		108 kW
240V/3/60Hz					80 kW	108 kW	
480V/3/60Hz			80 & 108 kW	150 kW		200 kW	250kW
600V/3/60Hz		80 kW	108 kW	150 kW	200 kW	250 kW	

Model	Air Flow	Electric Heater Air Pressure Drop (in w.c.)						
	CFM Std. Air							
YPAL106-130	24000	0.03	0.05	0.08	0.10	0.12	0.15	0.17
	26000	0.03	0.06	0.09	0.12	0.15	0.17	0.20
	28000	0.04	0.07	0.10	0.14	0.17	0.20	0.23
	30000	0.04	0.08	0.12	0.16	0.19	0.23	0.27
	32000	0.05	0.09	0.14	0.18	0.22	0.26	0.31
	34000	0.06	0.11	0.15	0.20	0.25	0.30	0.34
	36000	0.06	0.12	0.17	0.23	0.28	0.33	0.39
	38000	0.07	0.13	0.19	0.25	0.31	0.37	0.43
	40000	0.08	0.15	0.21	0.28	0.34	0.41	0.48
	42000	0.09	0.16	0.23	0.31	0.38	0.45	0.53
	44000	0.10	0.18	0.26	0.34	0.42	0.50	0.58
	46000	0.11	0.19	0.28	0.37	0.46	0.54	0.63

Exhaust Fan Data

EXHAUST FAN MOTOR SIZING INSTRUCTIONS

In order to determine the proper exhaust fan motor size, add the return duct static pressure to the appropriate damper pressure drop value in Table 23 to get the total static pressure applied to the exhaust fan. Based on the exhaust fan air flow and total static pressure, determine the brake horsepower and RPM of the exhaust fan.

TABLE 33 – EXHAUST FAN PERFORMANCE

FAN TYPE	15x15	18x18	20x18	32x32
YPAL050-065	X	X		
YPAL070-085		X	X	
YPAL090-095		X	X	
YPAL106-130				X

TABLE 34 – YPAL050-065 : 15X15 FORWARD CURVED FAN

TOTAL STATIC PRESSURE (inches of water column)								
CFM STD. AIR	0.25		0.50		0.75		1.00	
	BHP	RPM	BHP	RPM	BHP	RPM	BHP	RPM
6000	0.8	432	1.2	532	1.6	630	2.1	731
8000	1.7	509	2.1	594	2.6	671	3.0	738
10000	2.9	596	3.5	670	4.1	734	4.6	798
12000	4.6	699	5.4	746	6.1	810	6.8	863
14000	7.1	804	7.9	836	8.8	887	9.7	941
15000	8.6	857	9.4	887				

TABLE 35 – YPAL050-105 : 18X18 FORWARD-CURVED FAN

TOTAL STATIC PRESSURE (inches of water column)								
CFM STD. AIR	0.25		0.50		0.75		1.00	
	BHP	RPM	BHP	RPM	BHP	RPM	BHP	RPM
6000	0.6	332	0.9	433	1.4	526	1.9	604
8000	1.0	370	1.5	465	1.9	543	2.3	605
10000	1.7	413	2.2	495	2.8	572	3.4	642
12000	2.6	459	3.3	539	3.9	601	4.6	664
14000	3.8	509	4.6	581	5.4	645	6.1	697
16000	5.4	562	6.3	626	7.3	687	8.1	741
18000	7.3	617	8.5	675	9.5	730	10.5	784
20000	9.6	672	11.1	726	12.2	776	13.4	826
22000	12.3	728	14.1	779	15.5	825	16.7	870
24000	15.6	785	17.7	832	19.3	876		
26000	19.3	843						

NOTE: For performance at operating points not included in these tables, consult your local YORK representative.

TABLE 36 – YPAL070-105 : 20X18 FORWARD-CURVED FAN

TOTAL STATIC PRESSURE (inches of water column)								
CFM STD. AIR	0.25		0.50		0.75		1.00	
	BHP	RPM	BHP	RPM	BHP	RPM	BHP	RPM
12000	1.7	317	2.4	397	3.2	470	3.9	531
14000	2.4	343	3.2	414	4.1	482	5.0	544
16000	3.4	372	4.2	437	5.1	496	6.1	556
18000	4.6	403	5.5	461	6.5	516	7.5	569
20000	6.0	434	7.0	488	8.1	540	9.2	587
22000	7.7	467	8.9	517	10.0	564	11.2	610
24000	9.7	499	11.1	547	12.3	591	13.6	634
26000	11.9	532	13.6	578	14.9	619	16.3	659
28000	14.5	566	16.5	610	18.0	648	19.4	686
30000	17.5	599	19.8	642	21.4	679	22.9	714
32000	20.7	633	23.4	674	25.3	710	26.9	744
34000	24.4	667	27.5	707	29.6	742		
36000	28.4	701						

NOTE: For performance at operating points not included in these tables, consult your local YORK representative.

TABLE 37 – YPAL106-130 : 32" FORWARD-CURVED FAN

TOTAL STATIC PRESSURE (inches of water column)												
CFM STD. AIR	0.25		0.50		0.75		1.00		1.25		1.50	
	BHP	RPM	BHP	RPM	BHP	RPM	BHP	RPM	BHP	RPM	BHP	RPM
24000	4.9	248	6.1	280	7.2	313	8.5	347	9.9	379	11.4	410
26000	6.2	264	7.4	293	8.6	324	10.0	355	11.4	386	12.9	415
28000	7.4	280	8.7	306	10.0	334	11.4	363	12.8	392	14.4	420
30000	9.0	297	10.4	321	11.8	347	13.3	374	14.7	401	16.4	428
32000	10.6	313	12.0	335	13.6	359	15.1	384	16.6	409	18.3	435
34000	12.6	330	14.1	351	15.8	373	17.4	397	19.0	420	20.7	444
36000	14.6	347	16.2	366	18.0	387	19.7	409	21.4	431	23.1	453
38000	17.1	364	18.8	383	20.7	402	22.5	423	24.3	443	26.1	464
40000	19.6	381	21.4	399	23.3	417	25.2	436	27.1	455	29.0	475
42000	22.7	399	24.6	416	26.5	433	28.5	451	30.5	469	32.5	488
44000	25.7	416	27.7	432	29.7	448	31.8	465	33.9	482	36.0	500
46000	29.2	434	31.2	449	33.3	464	35.5	480	37.7	496		

NOTE: For performance at operating points not included in these tables, consult your local YORK representative.

Return Fan Data

TABLE 38 – RETURN FAN PERFORMANCE

FAN TYPE	2X245	2X270	1X445
YPAL050-065	X		
YPAL070-085		X	
YPAL090-105		X	
YPAL106-130			X

TABLE 39 – YPAL050-065 : 245 SWSI AIRFOIL FAN

TOTAL STATIC PRESSURE (inches of water column)										
CFM	1.0		1.5		2.0		2.5		3.0	
STD. AIR	BHP	RPM	BHP	RPM	BHP	RPM	BHP	RPM	BHP	RPM
14000	4.9	1104	6.5	1202	8.2	1290	9.9	1371	11.7	1451
16000	6.2	1207	8.0	1296	9.9	1380	11.8	1457	13.7	1530
18000	7.8	1314	9.7	1395	11.8	1474	14.0	1548	16.1	1618
20000	9.7	1425	11.8	1499	14.0	1572	16.4	1642	18.8	1709
22000	12.1	1538	14.2	1607	16.6	1674	19.1	1739	21.7	1803
24000	14.8	1655	17.1	1717	19.5	1780	22.2	1841	24.9	1900
26000	17.9	1773	20.5	1830	23.0	1888	25.7	1945		

TABLE 40 – YPAL070-105 : 270 SWSI AIRFOIL FAN

TOTAL STATIC PRESSURE (inches of water column)										
CFM	1.0		1.5		2.0		2.5		3.0	
STD. AIR	BHP	RPM	BHP	RPM	BHP	RPM	BHP	RPM	BHP	RPM
16000	5.4	966	7.3	1056	9.2	1139	11.2	1217	13.3	1295
18000	6.6	1041	8.6	1126	8.6	1126	12.9	1277	16.1	1618
20000	7.9	1119	10.2	1198	12.5	1272	14.9	1342	18.8	1709
22000	9.6	1199	12.0	1273	14.5	1343	17.1	1410	21.7	1803
24000	11.5	1283	14.0	1351	16.8	1417	19.5	1481	24.9	1900
26000	13.7	1369	16.4	1430	19.3	1493	22.2	1554	25.1	1611
28000	16.2	1456	19.0	1512	22.0	1571	25.2	1629	28.4	1684
30000	19.0	1544	22.0	1597	25.1	1651	28.5	1705	31.9	1759
32000	22.2	1633	25.4	1683	28.6	1733	32.1	1784	35.7	1835
34000	25.7	1723	29.1	1770	32.5	1817	36.1	1864	39.8	1912
36000	29.7	1813	33.3	1859	36.9	1902				

NOTE: For performance at operating points not included in these tables, consult your local YORK representative.

TABLE 41 – YPAL106-130 : 445 PLENUM FAN

TOTAL STATIC PRESSURE (inches of water column)												
CFM	0.25		0.50		0.75		1.00		1.25		1.50	
STD. AIR	BHP	RPM	BHP	RPM	BHP	RPM	BHP	RPM	BHP	RPM	BHP	RPM
24000	5.5	563	6.7	592	8.0	623	9.4	655	10.8	683	12.0	709
26000	6.9	606	8.2	633	9.5	661	11.0	690	12.5	718	13.9	744
28000	8.3	648	9.6	673	11.0	698	12.6	725	14.2	752	15.8	778
30000	10.1	691	11.5	715	13.0	738	14.6	763	16.3	788	18.0	813
32000	11.9	734	13.4	756	15.0	777	16.6	800	18.4	823	20.2	847
34000	14.2	778	15.8	798	17.5	818	19.2	839	21.0	861	22.9	883
36000	16.5	821	18.2	840	19.9	859	21.7	878	23.5	898	25.5	919
38000	19.4	865	21.1	883	22.9	901	24.8	919	26.7	938	28.7	957
40000	22.2	908	24.0	925	25.9	942	27.8	960	29.8	977	31.9	995
42000	25.7	952	27.6	968	29.6	985	31.6	1001	33.6	1018	35.8	1035
44000	29.1	995	31.1	1011	33.2	1027	35.3	1042	37.4	1058	39.6	1074
46000	33.1	1039	35.2	1054	37.3	1069	39.5	1084	41.7	1099	44.0	1114

TOTAL STATIC PRESSURE (inches of water column)												
CFM	1.75		2.00		2.25		2.50		2.75		3.00	
STD. AIR	BHP	RPM	BHP	RPM	BHP	RPM	BHP	RPM	BHP	RPM	BHP	RPM
24000	13.3	732	14.5	755	15.8	776	17.1	797	18.5	819	19.8	839
26000	15.2	767	16.7	790	18.1	810	19.5	830	20.9	851	24.7	900
28000	17.4	802	18.9	824	20.3	844	21.8	863	23.2	882	30.7	968
30000	19.6	836	21.4	858	23.0	879	24.6	898	26.2	917	37.6	1037
32000	22.1	870	23.9	892	25.7	913	27.4	933	29.1	951	45.4	1105
34000	24.7	905	26.8	927	28.7	948	30.6	968	32.5	986		
36000	27.5	940	29.6	961	31.7	982	33.8	1002	35.8	1020		
38000	30.7	976	33.0	997	35.2	1017	37.4	1036	39.6	1055		
40000	34.1	1013	36.3	1032	38.6	1051	40.9	1070	43.3	1089		
42000	37.8	1051	40.3	1070	42.7	1088	45.0	1106	47.3	1123		
44000	41.9	1090	44.2	1107	46.7	1124	49.1	1141				
46000	46.3	1130	48.7	1145								

NOTE: For performance at operating points not included in these tables, consult your local YORK representative.

Electrical Data

ELECTRICAL SERVICE SIZING

In order to use the electrical service required for the cooling only eco² rooftop, use the appropriate calculations listed below from U.L. 1995. Based on the configuration of the rooftop, the calculations will yield different MCA (minimum circuit ampacity), and MOP (maximum overcurrent protection).

Using the following load definitions and calculations, determine the correct electrical sizing for your unit. All concurrent load conditions must be considered in the calculations, and you must use the highest value for any combination of loads.

Load Definitions:

- **LOAD1** is the current of the largest motor – compressor or fan motor.
- **LOAD2** is the sum of the remaining motor currents that may run concurrently with LOAD1.

- **LOAD3** is the current of the electric heaters – zero for cooling only units.
- **LOAD4** is the sum of any remaining currents greater than or equal to 1.0 amp.

Use the following calculations to determine MCA and MOP for units supplied with a single-point power connection:

$$\text{MCA} = (1.25 \times \text{LOAD1}) + \text{LOAD2} + \text{LOAD3} + \text{LOAD4}$$

$$\text{MOP} = (2.25 \times \text{LOAD1}) + \text{LOAD2} + \text{LOAD3} + \text{LOAD4}$$

If the MOP does not equal a standard current rating of an overcurrent protective device, then the marked maximum rating is to be the next lower standard rating. However, if the device selected for MOP is less than the MCA, then select the lowest standard maximum fuse size greater than or equal to the MCA.

TABLE 42 – COMPRESSOR DATA — R407C

MODEL	COMPRESSOR		NOMINAL VOLTAGE									
	QUANTITY PER UNIT	MODEL	208/3/60		230/3/60		460/3/60		575/3/60		380/3/60	
			RLA*	LRA	RLA*	LRA	RLA*	LRA	RLA*	LRA	RLA*	LRA
50	4	ZR16	48.8	350	42.4	350	21.2	158	17.0	125	25.9	195
55	4	ZR16	48.8	350	42.4	350	21.2	158	17.0	125	25.9	195
60	4	ZR19	57.6	425	51.7	425	25.9	187	20.7	148	31.5	239
65	4	ZR19	57.6	425	51.7	425	25.9	187	20.7	148	31.5	239
70	4	ZR12	38.3	278	34.2	278	17.1	127	13.7	100	20.9	151
	2	ZR16	48.8	350	42.4	350	21.2	158	17.0	125	25.9	195
75	4	ZR12	38.3	278	34.2	278	17.1	127	13.7	100	20.9	151
	2	ZR16	48.8	350	42.4	350	21.2	158	17.0	125	25.9	195
80	6	ZR16	48.8	350	42.4	350	21.2	158	17.0	125	25.9	195
85	6	ZR16	48.8	350	42.4	350	21.2	158	17.0	125	25.9	195
90	2	ZR16	48.8	350	42.4	350	21.2	158	17.0	125	25.9	195
	4	ZR19	57.6	425	51.7	425	25.9	187	20.7	148	31.5	239
95	2	ZR16	48.8	350	42.4	350	21.2	158	17.0	125	25.9	195
	4	ZR19	57.6	425	51.7	425	25.9	187	20.7	148	31.5	239
105	6	ZR19	57.6	425	51.7	425	25.9	187	20.7	148	31.5	239

NOTE: *RLA data is per compressor

**For YPAL106-130, contact YORK.

TABLE 43 – COMPRESSOR DATA — R22

MODEL	COMPRESSOR		NOMINAL VOLTAGE							
	QUANTITY PER UNIT	MODEL	200/3/60		230/3/60		460/3/60		575/3/60	
			RLA*	LRA	RLA*	LRA	RLA*	LRA	RLA*	LRA
50	4	ZR16	46.9	350	40.8	350	20.4	158	16.3	125
55	4	ZR16	46.9	350	40.8	350	20.4	158	16.3	125
60	4	ZR19	55.2	425	51.5	425	25.8	187	20.6	148
65	4	ZR19	55.2	425	51.5	425	25.8	187	20.6	148
70	4	ZR12	38.3	278	33.3	278	16.7	127	13.3	100
	2	ZR16	46.9	350	40.8	350	20.4	158	16.3	125
75	4	ZR12	38.3	278	33.3	278	16.7	127	13.3	100
	2	ZR16	46.9	350	40.8	350	20.4	158	16.3	125
80	6	ZR16	46.9	350	40.8	350	20.4	158	16.3	125
85	6	ZR16	46.9	350	40.8	350	20.4	158	16.3	125
90	2	ZR16	46.9	350	40.8	350	20.4	158	16.3	125
	4	ZR19	55.2	425	51.5	425	25.8	187	20.6	148
95	2	ZR16	46.9	350	40.8	350	20.4	158	16.3	125
	4	ZR19	55.2	425	51.5	425	25.8	187	20.6	148
105	6	ZR19	55.2	425	51.5	425	25.8	187	20.6	148
106	6	ZR19	54.7	425	48.0	425	23.8	187	21.1	148
110	6	ZR19	55.5	425	48.1	425	24.0	187	21.1	148
115	2	ZR19	56.4	425	48.9	425	24.4	187	19.6	148
	4	ZR250	78.3	505	73.0	505	31.1	225	24.9	180
130	6	ZR250	73.0	505	73.0	505	31.4	225	25.2	180

NOTE: *RLA data is per compressor

TABLE 44 – SUPPLY AND EXHAUST FAN MOTOR (ODP OR TEFC)**High Efficiency**

MOTOR HP	NOMINAL VOLTAGE				
	208/3/60	230/3/60	380/3/60	460/3/60	575/3/60
	FLA	FLA	FLA	FLA	FLA
5	16.1	13.2	8.3	6.6	5.3
7.5	25.0	21.6	13.3	10.8	8.2
10	33.0	28.4	17.5	14.2	11.4
15	44.8	40.6	24.5	20.3	16.2
20	61.0	50.0	32.0	25.0	20.0
25	74.0	62.0	39.0	31.0	24.2
30	87.0	74.0	46.0	37.0	29.6
40	113.0	98.0	59.0	49.0	38.8
50	144.0	124.0	73.0	62.0	49.2
60	—	144.0	87.0	72.0	57.4

Premium Efficiency

MOTOR HP	NOMINAL VOLTAGE				
	208/3/60	230/3/60	380/3/60	460/3/60	575/3/60
	FLA	FLA	FLA	FLA	FLA
5	15.2	13.4	8.0	6.7	5.4
7.5	24.8	20.4	12.0	10.2	8.2
10	29.0	25.8	17.2	12.9	10.3
15	42.4	37.0	22.6	18.5	14.8
20	56.0	48.0	32.5	24.0	19.0
25	69.5	60.0	39.0	30.0	24.2
30	83.0	72.0	46.0	36.0	29.0
40	111.0	94.0	57.0	47.0	37.4
50	137.0	118.0	72.0	59.0	46.0
60	162.0	138.0	84.0	69.0	56.0

TABLE 45 – POWER SUPPLY VOLTAGE LIMITS

Power Supply	Minimum voltage	Maximum voltage
200V/3Ph/60Hz	180	228
230V/3Ph/60Hz	207	253
460V/3Ph/60Hz	414	506
575V/3Ph/60Hz	518	632

TABLE 46 – CONDENSER FAN MOTOR RLA

RLA EACH MOTOR		208V/3PH/60HZ	230V/3PH/60HZ	460V/3PH/60HZ	575V/3PH/60HZ
		7.3	6.2	3.1	2.5
MODEL	QUANTITY OF FANS	208V/3PH/60HZ	230V/3PH/60HZ	460V/3PH/60HZ	575V/3PH/60HZ
YPAL050-065	4	29.2	24.8	12.4	10.0
YPAL070-130	6	43.8	37.2	18.6	15.0

Electrical Data (continued)

TABLE 47 – MISCELLANEOUS ELECTRICAL DATA

DESCRIPTION	NOMINAL VOLTAGE				
	208V	230V	460V	575V	380V-60
	AMPS	AMPS	AMPS	AMPS	AMPS
Contrl X'fmr, 750 VA	3.6	3.3	1.6	1.3	2
Contrl X'fmr, 1.0 KVA	4.8	4.4	2.2	1.8	2.6
Convenience Outlet	9.6	8.7	4.4	3.5	N/A
Gas Heat	9.6	8.7	4.4	3.5	5.3

TABLE 48 – ELECTRIC HEAT AMP DRAW

KW*	200V/3Ph/60Hz	240V/3Ph/60Hz	480V/3Ph/60Hz	600V/3Ph/60Hz	400V/3Ph/50Hz
	AMPS	AMPS	AMPS	AMPS	AMPS
40	96	96	48	40	56
80	193	193	96	80	111
108	260	260	130	109	150
150			181	151	209
200			241	201	279
250			301	251	

Notes:

- Heaters will be sized as follows: 208V heaters rated at 208V, 230V heaters rated at 240V, 460V heaters rated at 480V, 575V heaters rated at 600V.

Controls

CONTROL SEQUENCES COMMON TO ALL UNITS

GENERAL

The control system for the YORK eco² Packaged Rooftop Unit is fully self-contained and based around a Rooftop Unit controller. To aid in unit setup, maintenance, and operation, the rooftop unit controller is equipped with a user interface that is based around a 4 line x 20 character backlit LCD display. The LCD displays plain language text in a menu-driven format to facilitate use. In addition to the display, the Rooftop unit user interface is also equipped with an LED indicator light, which will warn of any abnormal operation of the equipment or communication failures.

For the maximum in system flexibility, the YORK eco² Packaged Rooftop Unit can be operated by either a typical 7-wire thermostat (2 cool/2 heat), a space temperature sensor, or stand-alone (VAV only). Note, a field wiring terminal block is provided to facilitate unit setup and installation.

In lieu of the hard-wired control options, the rooftop unit controller can be connected to and operated by a Building Automation System (BAS). If required, the Rooftop Unit controller can be equipped with an optional BACNet IP communication card, which allows communication, via Ethernet, to a BACNet IP based BAS.

ROOFLINK™

The optional RoofLink™ control board will allow the building owner increased flexibility through the use of expanded binary and analog inputs and outputs to the OptiLogic controls system. When a building is using an automation system other than LON or BACnet, the RoofLink™ will allow for easy connections and communications to and from the OptiLogic controls through a twisted pair connection. There are 5 analog inputs, 3 analog outputs and 4 binary inputs/outputs. This allows the user to send and retrieve information either through contact closures or voltage signals to and from the unit. A technician or building manager now has access to specific information concerning the operating rooftop functions. The Rooflink™ also includes expanded smoke purge capabilities through additional contacts on the Rooflink™ board that are not found on the standard OptiLogic controls. This provides even greater flexibility for building protection and occupant safety.

UNOCCUPIED / OCCUPIED SWITCHING

Depending on application, the unit can be indexed between unoccupied and occupied modes of operation by one of three methods, hard-wired input, internal time clock, or BAS. A contact-closure input is provided for

hard-wiring to an external indexing device such as a central time clock, thermostat with built in scheduling, or a manual switch. The unit controller is also equipped with a built in 7-day time clock which can be used, in lieu of the contact closure input, to switch the unit between Unoccupied and Occupied modes of operation. The internal time clock is fully configurable via the user interface and includes Holiday scheduling. In addition to the hard-wired input or the internal time clock, the unit can also be indexed between unoccupied and occupied modes of operation via a BAS command.

Note: a unit operated from a space sensor with override buffer can be equipped to temporarily override an unoccupied mode of operation. This Unoccupied Override feature is fully configurable via the Rooftop Unit user interface.

GAS HEATING OPERATION

Units supplied with gas heat can be equipped one, two, or three independently operated burner modules. Each module is fully self-contained furnace with all necessary ignition controls, safeties, and gas valves. The OptiLogic rooftop unit controller determines how the furnaces are started and stopped and prevents furnace operation if the Supply Fan airflow is not sufficient or if the Supply Air Temperature is excessively high.

If a furnace module receives a signal to start from the OptiLogic controller, the ignition control engages the furnace inducer (draft) fan for a 30-second pre-purge cycle. At the end of the 30-second pre-purge, the ignition control will stop the furnace and allows the inducer fan to operate for a 30-second post-purge. Each furnace contains a direct spark ignition system and included safeties for flame and inducer fan verification, high temperature and flame roll-out.

HYDRONIC HEAT

If the unit is configured with either of the wet heat options (steam or hot water) the Rooftop Unit controls will modulate the hydronic valve to maintain a supply air set point. In the event temperatures off the hydronic coil are below 34 degrees the fans will be shut down and the hydronic valve will open 100%. This function is an automatic reset so as the temperature rises above 36 degrees, the unit will automatically begin normal operation.

ELECTRIC HEATING OPERATION

For units equipped with electric heaters, the unit can control up to six stages of electric heat which are staged

Controls (continued)

on based on heating demand calculates by the OptiLogic controller.

MORNING WARM-UP

Morning Warm-Up can be initialized by BAS or by the OptiLogic controller if the Internal Scheduling is used. If the Internal Scheduling is used, the Morning Warm-Up start time is calculated through an adaptive algorithm.

When Morning Warm-Up is required, the OptiLogic controller energizes the VAV heat relay, starts the Supply Fan and qualifies the Return Air Temperature for 5 minutes. The internal heat source (Gas, HW/Steam, or Electric) is controlled to maintain the Return Air Temperature to the Morning Warm-Up Setpoint, Morning Warm-Up ends when occupancy occurs (BAS, Internal Scheduling, or contact closure), or when the Maximum Morning Warm-Up Time has expired.

ECONOMIZER OPERATION

The unit can be equipped with one of three types of optional economizers, dry bulb, single enthalpy, or comparative enthalpy. When the unit controller determines that Outside Air is suitable for economizing, the unit controller will control the outside air damper(s) open to provide economizer cooling. If economizer cooling alone is insufficient for the cooling load, the unit controller shall stage up compressors, one at a time, to meet demand.

The control logic for the three types of economizers is as follows:

Dry Bulb Economizer

The dry bulb economizer is the default economizer control scheme. With the dry bulb economizer, the unit controller monitors the Outside Air temperature only and compares it to a reference temperature setting. Outside Air is deemed suitable for economizing when the Outside Air temperature is determined to be less than the reference temperature setting. This method of economizing is effective, but is prone to some change-over inefficiencies due to the fact that this method is based on sensible temperatures only and does not take Outside Air moisture content into consideration.

Single Enthalpy Economizer

With the optional single enthalpy economizer, the unit controller monitors the Outside Air enthalpy in addition to the Outside Air temperature and compares it to a reference enthalpy setting and a reference temperature setting. Outside Air is deemed suitable for econo-

mizing when the Outside Air enthalpy is determined to be less than the reference enthalpy setting and the Outside Air temperature is less than the reference temperature setting. This method of economizing allows the reference temperature setting to be set higher than the DB Economizer and is consequently a more efficient packaged rooftop economizer.

Dual Enthalpy Economizer

With the optional dual enthalpy economizer, the unit controller monitors and compares the Outside Air and Return Air enthalpies in addition to comparing the Outside Air temperature to the reference temperature setting. Outside Air is deemed suitable for economizing when the Outside Air enthalpy is determined to be less than the Return Air enthalpy and the Outside Air temperature is less than the reference temperature setting. This method of economizing is the most accurate and provides the highest degree of energy efficiency for a packaged rooftop economizer.

VENTILATION CONTROL SEQUENCES

Minimum OA Damper Position (CV Units)

When the unit goes into the Occupied mode of operation, the unit controller shall open the Outside Air Damper to a fixed minimum position. The damper shall remain at this position as long as the unit is in the occupied mode, and the economizer is not suitable for cooling.

Minimum OA Damper Position (VAV Units)

With Variable Air Volume units, there are two Minimum OA Damper Positions, one when the unit is at full speed and the second when the unit is at approximately half speed. These two points allow the control to linearly reset the position of the OA damper in response to fan speed.

When the unit goes into the Occupied mode of operation, the unit controller shall monitor the speed of the supply fan and open the Outside Air damper to a calculated minimum position based on the fan speed. This minimum position shall vary as the speed of the fan changes. The damper shall remain at this calculated position as long as the unit is in the occupied mode, and the economizer is not suitable for cooling.

Air Measurement Stations

When the unit is equipped with an air measurement station, the unit controller shall control the Outside Air damper to a measured flow rate through the Air Measurement Station.

When the unit goes into the Occupied mode of operation, the unit controller shall control the Outside Air damper to maintain the Minimum AirFlow Setpoint

through the Air Measurement Station. The unit controller shall control the Outside Air damper to this flow rate as long as the unit is in the Occupied mode, and the economizer is not suitable for cooling.

Demand Ventilation

If an optional CO₂ sensor is connected to the unit, the unit controller can reset the minimum OA damper position(s) or minimum flow rate based on demand.

The unit controller shall monitor the CO₂ level within the building. If the CO₂ level rises above the CO₂ setpoint, the controller will temporarily increase the Minimum OA Damper Position or Minimum OA flow rate to increase ventilation. If the CO₂ level drops below the CO₂ setpoint, the controller will decrease the Minimum OA Damper Position or Minimum OA flow rate to decrease ventilation.

Demand Ventilation shall remain active as long as the unit is in the Occupied mode of operation.

EXHAUST CONTROL SEQUENCES

Barometric

The optional barometric exhaust system consists of a lightweight barometric relief damper installed on the end of the unit in the Return Air section. As more outside air is introduced into the controlled zone due to Economizer and Ventilation control sequences, the pressure inside the building rises. As building static pressure increases to overcome any exhaust duct static pressure, air will be allowed to escape through the barometric relief damper. Because this type of exhaust is not powered, the amount of air exhausted will be limited to the static pressure that will need to be overcome.

Powered Variable Volume Exhaust-Discharge Damper Controlled

This optional variable volume powered exhaust system consists of a fixed speed fan configured with a proportionally controlled discharge damper. The Rooftop Unit controller monitors the pressure inside the building and controls the Exhaust Damper and the Exhaust Fan. If the Building Pressure rises, the Exhaust Damper is proportionally controlled open and the Exhaust Fan is controlled ON. If the Building Pressure falls, the Exhaust Damper is proportionally controlled closed and the Exhaust Fan is controlled OFF. The position of the Exhaust Damper in which the Exhaust Fan is controlled ON and OFF as well as the Building Pressure setpoint is user selectable from the Rooftop Unit User Interface.

Powered Variable Volume Exhaust-VFD Controlled

This optional variable volume powered exhaust system consist of an Exhaust Fan driven by a Variable Fre-

quency Drive (VFD), which is controlled by the Rooftop Unit controller. The Rooftop Unit controller monitors the pressure within the building. As the pressure rises, the VFD is controlled to increase Exhaust Fan speed. As the pressure falls, the VFD is controlled to decrease Exhaust Fan speed. The Building Pressure Setpoint is user selectable from the Rooftop Unit User Interface. On/Off control is maintained the same as Exhaust-Discharge Damper control stated above.

Return Fan Controlled

This optional variable volume powered return fan system consists of two return fans controlled by one VFD that is controlled by the Rooftop Unit control center. The VFD is controlled to maintain a slightly positive pressure over the mixing box section to prevent reverse flow. As the return and/or exhaust air dampers open, the return plenum pressure drops, the fan will speed up to maintain pressure. When the return and/or exhaust air dampers close, the return plenum pressure increases causing the VFD to slow the fan speed down.

LOW AMBIENT/HEAD PRESSURE CONTROL OPERATION

The Rooftop Unit controller continuously monitors the outside air temperature to determine if mechanical cooling should be allowed. As a safety, if the Outside Air temperature falls to or below the Low Ambient Lockout temperature, mechanical cooling is prevented from operating. For units with economizers, the Low Ambient Lockout temperature is typically low enough that mechanical cooling will rarely be required. However, for some applications mechanical cooling is required when the Outside Air temperature is lower than the Low Ambient Lockout temperature.

For these applications, the unit must be equipped with optional Low Ambient controls. For optional Low Ambient operation, the Rooftop Unit controller monitors the refrigeration system discharge pressure and controls the speed of the condenser fans. If the discharge pressure falls, the speeds of the condenser fans are reduced to maintain acceptable condensing pressures in the refrigeration system. With the optional Low Ambient controls, mechanical cooling is allowed down to Outside Air temperatures of 0°F.

SMOKE PURGE SEQUENCES

General

As a convenience, for when buildings catch fire or the building is inundated with smoke or fumes from manufacturing processes, etc.

The Oplilogic controls of the Eco² are designed as stan-

Controls (continued)

standard with a Ventilation Override sequence to remove, exhaust or ventilate smoke, fumes or other air born contaminants from the occupied space. This feature offers 5 selectable operations, which include, Shutdown, Pressurization, Exhaust, Purge and Purge with duct pressure control. Once the selected operation is programmed through the Optilogic user interface, a contact closure input will initiate the selected ventilation sequence. Some typical contact closures are smoke detectors, fire alarms, manual switches etc . . . If desired, the Rooflink™ option can be added to the controls system for more ventilation mode operations.

Note: all cooling and heating modes are disabled during any ventilation mode.

Shutdown

When this purge sequence is selected and activated, the supply and exhaust fans are controlled OFF and the Outside Air damper is overridden closed. This idle state is maintained until the purge input is deactivated and the unit returns to normal operation.

Pressurization

When this purge sequence is selected and activated, the exhaust fan is controlled OFF and the Supply Fan is controlled ON. The Outside Air damper is opened full and the Return Air Damper is closed full. If the unit is a VAV unit, the VAV boxes are also driven full open to prevent duct over-pressurization. This mode is maintained until the smoke purge input is deactivated and the unit returns to normal operation.

Exhaust

When this purge sequence is selected and activated, the Supply Fan is controlled OFF and the Exhaust Fan is controlled ON (Exhaust Damper driven full open and the outside air damper is closed). This mode is maintained until the smoke purge input is deactivated and the unit returns to normal operation.

Purge

When this purge sequence is selected and activated, the Supply Fan is controlled ON and the Exhaust Fan is controlled ON. The Outside Air damper is opened full and the Return Air damper is closed full. If the unit is a VAV unit, the VAV boxes are also driven full open to prevent duct over-pressurization. This mode is maintained until the smoke purge input is deactivated and the unit returns to normal operation.

Purge With Duct Pressure Control (VAV Only)

When this purge sequence is selected and activated, the Supply Fan is cycled ON and controlled to maintain the duct static pressure setpoint. The Exhaust Fan is also controlled ON (Exhaust Damper driven full open) and the Outside Air Damper is driven full open. This mode is maintained until the smoke purge input is deactivated and the unit returns to normal operation.

VAV SPECIFIC SEQUENCES

SUPPLY FAN OPERATION

For VAV units, the supply fan is controlled ON and OFF based on the occupancy state or the G input from a Thermostat (Unit must be configured for Thermostat operation to respond to the G input). When the unit goes into the Occupied mode of operation (or "G" is called) the Supply Fan will be controlled ON. The Rooftop Unit controller will monitor the static pressure within the supply duct system and control the speed of the supply fan to maintain a specified Duct Static Pressure setpoint. A Variable Frequency Drive (VFD) is used on all VAV units to vary the speed of the supply fan. Note, the use of a VFD in lieu of inlet guide vanes provides for higher energy efficiency for the unit by eliminating the losses (air pressure drop) typical of inlet guide vane systems.

COOLING OPERATION

Thermostat Control

When a VAV unit is configured for thermostat operation, the Rooftop Unit controller will command the Supply Fan to start when the unit goes into the Occupied mode or a thermostat "G" signal is received by the control. With no thermostat calls for cooling, the unit shall remain idle with the Supply Fan operating as required.

When a Cooling Stage 1 call ("Y1") is received, and the unit is equipped with an economizer, the Rooftop Unit controller will check the Outside Air conditions to determine if conditions are suitable for economizing and modulate the outside air damper and/or stage up compressors as required to maintain the VAV High Supply Air Temperature Setpoint (default set to 60°F). This setpoint is user selectable at the Rooftop Unit User Interface. The Rooftop Unit controller will control to this setpoint as long as Cooling Stage 1 ("Y1") remains active.

When a Cooling Stage 2 call (“Y2”) is received, and the unit is equipped with an economizer, the Rooftop Unit controller will check the Outside Air conditions to determine if conditions are suitable for economizing and modulate the outside air damper and/or stage up compressors as required to maintain the VAV Low Supply Air Temperature Setpoint (default set to 55°F). This setpoint is user selectable at the Rooftop Unit User Interface. The Rooftop Unit controller will control to this setpoint as long as Cooling Stage 2 (“Y2”) remains active.

The VAV High SAT Setpoint is always greater than the VAV Low SAT Setpoint and because of this essentially makes this control sequence a Supply Air Temperature Reset algorithm based on Zone Temperature or Outside Air.

Zone Sensor Control

When a VAV unit is configured for Zone Sensor operation, the Rooftop Unit controller will monitor a reference Zone Temperature and command the Supply Fan to start when the unit goes into the Occupied mode.

If the zone temperature is above the VAV Setpoint for SAT Reset, the Rooftop Unit controller will modulate the outside air damper (Economizer available and conditions suitable) and/or stage compressors up and down, as required, to maintain the VAV High Supply Air Temperature Setpoint.

If the zone temperature is below or falls below the VAV Setpoint for SAT Reset, the Rooftop Unit controller will modulate the Outside Air Damper (Economizer available and conditions suitable) and/or stage compressors up and down, as required, to maintain the VAV High Supply Air Temperature Setpoint.

As with thermostat operation, this sequence is also a Supply Air Temperature Reset algorithm based on Zone Temperature.

Stand-Alone Control

If the unit is not configured for Thermostat or Zone Sensor operation, the unit will operate in Stand-Alone Mode.

In Stand-Alone Mode, the Rooftop Unit Controller will monitor only the Occupied/Unoccupied state. When the unit is commanded into the Occupied Mode of operation, the Rooftop Unit Controller will start the Supply Fan. If the unit is equipped with an Economizer, the Controller will check to see if Outside Air conditions are suitable for Economizing. The controller will then use Outside Air (when available and suitable) and/or stage compressors up and down, as required, to maintain the VAV Low SAT Setpoint.

Supply Air Tempering

Supply Air Tempering is a continuation of the a VAV cooling operation when the outside air temperature is below the supply air temperature setpoint where heating is used to maintain economizer operation. This function will use small increments of heat to maintain the Supply Air Temperature when the economizer dampening stages.

HEATING OPERATION

VAV Occupied Heating

When VAV Occupied Heating is enabled, full heating will energize when either the thermostat W1 or W2 signal is received or the space temperature falls below the VAV Setpoint for SAT Reset by more than 2°F. If the return air temperature falls below the return air temperature setpoint for occupied heating, full heat capacity will be energized.

On VAV units the supply fan speed is controlled to maintain static pressure allowing true VAV heating operation.

CV SPECIFIC SEQUENCES

COOLING OPERATION

Thermostat Control

If a 7-wire thermostat (2 Cool/2 Heat) controls the unit, all zone temperature setpoint control is maintained at the thermostat. With this operation, the unit remains idle until it receives a stage call from the thermostat. If “G” is called from the thermostat, the Supply Fan will start. Ventilation functions (if equipped) will be permitted to run with an occupied signal. Economizer functions will operate with a “G” call and a call for cooling.

Stage 1 (“Y1”) Call

If Y1 is called and the unit is equipped with an economizer, the control will check to see if the Outside Air is suitable for economizing. If conditions are suitable for economizing, the control will control the economizer and stage up compressors, as required, to maintain the economizer first-stage setpoint. If conditions are not suitable for economizing or not equipped with an economizer, the control will stage up 50% of the compressors. This shall be maintained until Stage 1 is deactivated or Stage 2 is called.

Stage 2 (“Y2”) Call

If Y2 is called and the unit is equipped with an economizer, the control will check to see if the Outside Air is suitable for economizing. If conditions are suitable for economizing, the control will control the economizer and stage up compressors, as required, to maintain the econo-

Controls *(continued)*

mizer second-stage setpoint. If conditions are not suitable for economizing or not equipped with an economizer, the control will stage up 100% of the compressors. This shall be maintained until Stage 2 is deactivated.

Zone Sensor Control

If a zone sensor controls the unit, the Rooftop Unit controller shall maintain the zone temperature setpoint. This setpoint is user selectable at the Rooftop Unit User Interface.

When a zone sensor is used for control, the Rooftop Unit controller will monitor the temperature within the space and control the unit accordingly. A closed-loop staging algorithm is used to stage compressors up and down as required to maintain the desired zone temperature setpoint. If the unit is equipped with an economizer, Outside Air conditions are continuously monitored by the control to determine if conditions are suitable for economizing. If conditions are suitable for economizing, the Rooftop Unit controller will modulate the Outside Air damper in addition to staging compressors up and down to maintain the zone temperature setpoint.

HEATING OPERATION

Thermostat Control

If a 7-wire thermostat (2 Cool/2 Heat) controls the unit, all zone temperature setpoint control is maintained at the thermostat. With this operation, the unit remains idle until it receives a stage call from the thermostat. If "G" is called from the thermostat, the Supply Fan will start. Ventilation functions (if equipped) will be permitted to run with an occupied signal.

Stage 1 ("W1") Call

If W1 is called and the unit is equipped with an economizer, the economizer will go to minimum position with an occupied signal or close with an unoccupied signal, and the control will stage up 50% of the heating steps. This shall remain active until Stage 1 call is deactivated or a Stage 2 call is activated.

Stage 2 ("W2") Call

If W2 is called and the unit is equipped with an economizer, the economizer will go to minimum position with an occupied signal or close with an unoccupied signal, and the control will stage up 100% of the heating steps. This shall remain active until Stage 2 call is deactivated.

Zone Sensor Control

If a zone sensor controls the unit, the Rooftop Unit controller shall maintain all zone temperature setpoints. These setpoints are user selectable at the Rooftop Unit User Interface.

When a zone sensor is used for control, the Rooftop Unit controller will monitor the temperature within the space and control the unit accordingly. A closed-loop staging algorithm is used to stage heating steps up and down as required to maintain the desired zone temperature setpoint. If the unit is equipped with an economizer, Outside Air conditions are continuously monitored by the control to determine if conditions are suitable for economizing. If conditions are suitable for economizing, the Rooftop Unit controller will modulate the Outside Air damper in addition to staging heating steps up and down to maintain the zone temperature setpoint.

TABLE 49 – THREE PHASE POWER SUPPLY CONDUCTOR SIZE RANGE**50-55 Ton Units**

Supply Voltage	Single Point TB	Single Point Disconnect	Dual Point TB TB 1	TB 2
208V	(2*) 250 kcmil-500 kcmil	(2*) 2 AWG-500 kcmil	6 AWG-400 kcmil	6 AWG-350 kcmil
230V	(2*) 250 kcmil-500 kcmil	(2*) 2 AWG-500 kcmil	6 AWG-400 kcmil	6 AWG-350 kcmil
380V-60	6 AWG-400 kcmil	6 AWG-350 kcmil	14 AWG-2/0	14 AWG-2/0
460V	6 AWG-400 kcmil	6 AWG-350 kcmil	14 AWG-2/0	14 AWG-2/0
575V	6 AWG-400 kcmil	6 AWG-350 kcmil	14 AWG-2/0	14 AWG-2/0

60-65 Ton Units

Supply Voltage	Single Point TB	Single Point Disconnect	Dual Point TB TB 1	TB 2
208V	(2*) 250 kcmil-500 kcmil	(2*) 2 AWG-500 kcmil	6 AWG-400 kcmil	6 AWG-350 kcmil
230V	(2*) 250 kcmil-500 kcmil	(2*) 2 AWG-500 kcmil	6 AWG-400 kcmil	6 AWG-350 kcmil
380V-60	6 AWG-400 kcmil	6 AWG-350 kcmil	14 AWG-2/0	14 AWG-2/0
460V	6 AWG-400 kcmil	6 AWG-350 kcmil	14 AWG-2/0	14 AWG-2/0
575V	6 AWG-400 kcmil	6 AWG-350 kcmil	14 AWG-2/0	14 AWG-2/0

70-75 Ton Units

Supply Voltage	Single Point TB	Single Point Disconnect	Dual Point TB TB 1	TB 2
208V	(2*) 250 kcmil-500 kcmil	(2*) 2 AWG-500 kcmil	4 AWG-500 kcmil	6 AWG-350 kcmil
230V	(2*) 250 kcmil-500 kcmil	(2*) 2 AWG-500 kcmil	6 AWG-400 kcmil	6 AWG-350 kcmil
380V-60	(2*) 3/0-250 kcmil	4 AWG-500 kcmil	6 AWG-400 kcmil	14 AWG-2/0
460V	(2*) 3/0-250 kcmil	4 AWG-500 kcmil	14 AWG-2/0	14 AWG-2/0
575V	6 AWG-400 kcmil	6 AWG-350 kcmil	14 AWG-2/0	14 AWG-2/0

80-85 Ton Units

Supply Voltage	Single Point TB	Single Point Disconnect	Dual Point TB TB 1	TB 2
208V	(3*) 2/0-400 kcmil	(2*) 2 AWG-500 kcmil	(2*) 2 AWG-500 kcmil	6 AWG-350 kcmil
230V	(2*) 250 kcmil-500 kcmil	(2*) 2 AWG-500 kcmil	4 AWG-500 kcmil	6 AWG-350 kcmil
380V-60	(2*) 3/0-250 kcmil	4 AWG-500 kcmil	6 AWG-400 kcmil	14 AWG-2/0
460V	(2*) 3/0-250 kcmil	4 AWG-500 kcmil	6 AWG-400 kcmil	14 AWG-2/0
575V	(2*) 3/0-250 kcmil	6 AWG-350 kcmil	14 AWG-2/0	14 AWG-2/0

90-105 Ton Units

Supply Voltage	Single Point TB	Single Point Disconnect	Dual Point TB TB 1	TB 2
208V	(3*) 2/0-400 kcmil	(2*) 2 AWG-500 kcmil	(2*) 2 AWG-500 kcmil	4 AWG-600 kcmil
230V	(3*) 2/0-400 kcmil	(2*) 2 AWG-500 kcmil	(2*) 2 AWG-500 kcmil	4 AWG-600 kcmil
380V-60	(2*) 3/0-250 kcmil	4 AWG-500 kcmil	4 AWG-500 kcmil	14 AWG-2/0
460V	(2*) 3/0-250 kcmil	4 AWG-500 kcmil	6 AWG-400 kcmil	14 AWG-2/0
575V	(2*) 3/0-250 kcmil	6 AWG-350 kcmil	14 AWG-2/0	14 AWG-2/0

* Note, indicates supply connection with multiple connection points per phase. (2 for 2* and 3 for 3*)

Controls (continued)

TABLE 49 – THREE PHASE POWER SUPPLY CONDUCTOR SIZE RANGE (cont'd)
106-130 Ton Unit

Supply Voltage	Single Point TB	Single Point Disconnect	Dual Point TB TB 1	TB 2
200V	4 AWG thru 500 kcmil (4 per phase)	4/0 thru 500 kcmil (4 per phase)	2 AWG thru 300 kcmil (2 per phase)	4 AWG thru 500 kcmil (2 per phase)
230V	4 AWG thru 500 kcmil (4 per phase)	4/0 thru 500 kcmil (4 per phase)	2 AWG thru 300 kcmil (2 per phase)	4 AWG thru 500 kcmil (2 per phase)
460V	6 AWG thru 500 kcmil (2 per phase)	3/0 thru 500 kcmil (2 per phase)	2 AWG thru 300 kcmil (2 per phase)	14 AWG thru 2/0 (1 per phase)
575V	6 AWG thru 500 kcmil (2 per phase)	3/0 thru 500 kcmil (2 per phase)	2 AWG thru 300 kcmil (2 per phase)	14 AWG thru 2/0 (1 per phase)

* Note, indicates supply connection with multiple connection points per phase. (2 for 2* and 3 for 3*)

Power Wiring: YPAL106-130

UNIT POWER SUPPLY WIRING, STANDARD SINGLE POINT, W/ OR W/O DISCONNECT

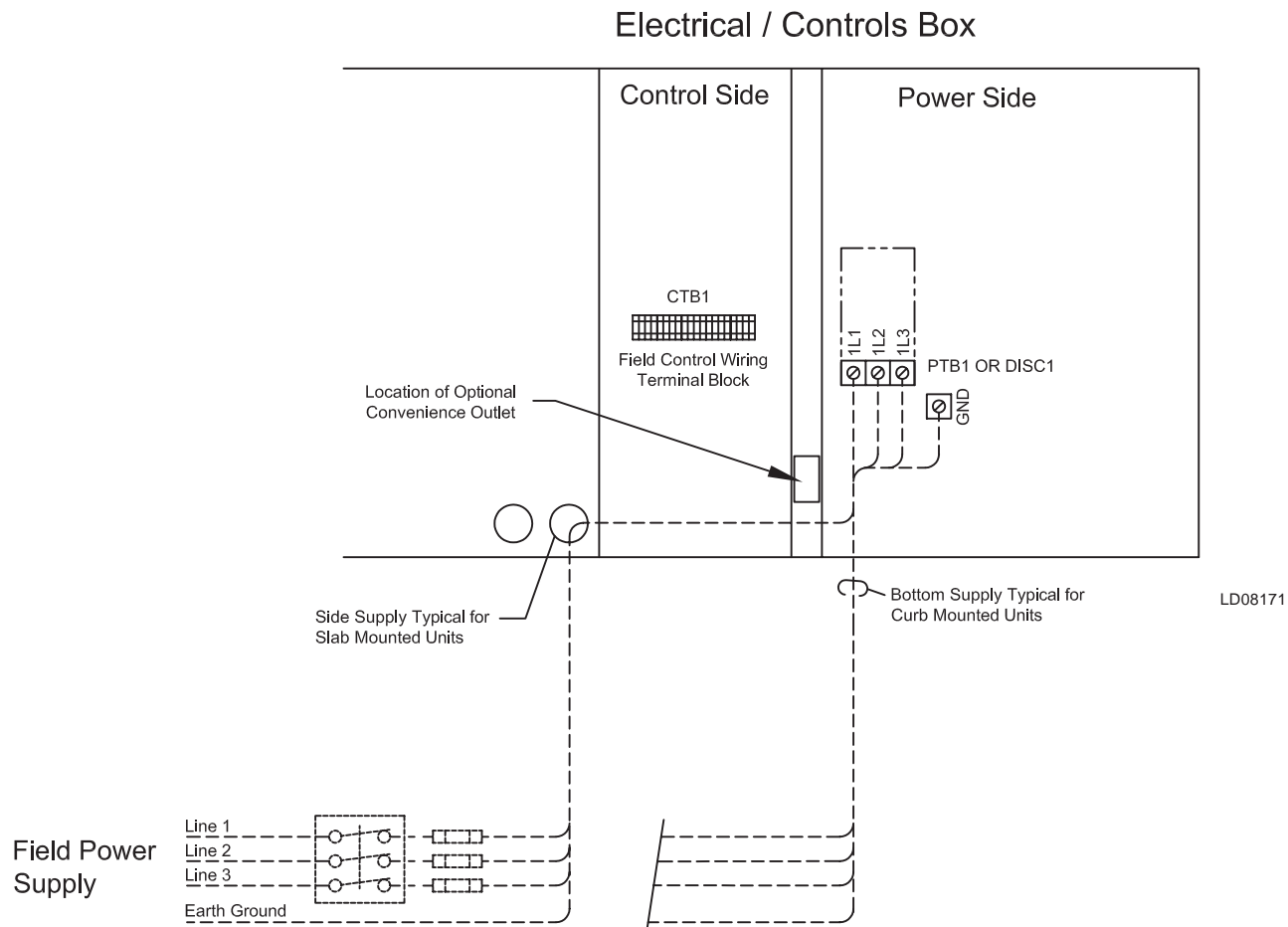

NOTES:

1. All field wiring must be provided through a field-supplied fused disconnect switch to the unit terminals (or optional molded disconnect switch).
2. All electrical wiring must be made in accordance with all N.E.C. and/or local code requirements.
3. Consult the I.O.M manual or unit nameplate data to determine Minimum Circuit Ampacities (MCA) and recommended Dual Element fuse sizes.
4. Minimum Circuit Ampacity (MCA) is based on U.L. Standard 1995, Section 36.14 (N.E.C. Section 440.34).
5. Maximum Dual Element Fuse size is based on U.L. Standard 1995, Section 36.15 (N.E.C. Section 440.22)
6. The "Incoming Wire Range" is the minimum and maximum wire sizes that can be accommodated by the unit wiring lugs. A (2) preceding the wire range indicates the number of termination points available per phase of the wire range specified. Actual wire size and number of wires per phase must be determined based on N.E.C.
7. Use copper conductors only.
8. On units with an optional disconnect switch, the supplied disconnect switch is a "Disconnecting Means" as defined in the N.E.C. Section 100, and is intended for isolating the unit from the available power supply to perform maintenance and troubleshooting. This disconnect switch is not intended to be a Load Break Device.

FIG. 3 – SINGLE-POINT POWER SUPPLY WIRING

Power Wiring: YPAL106-130 (continued)

UNIT POWER SUPPLY WIRING, OPTIONAL DUAL POINT

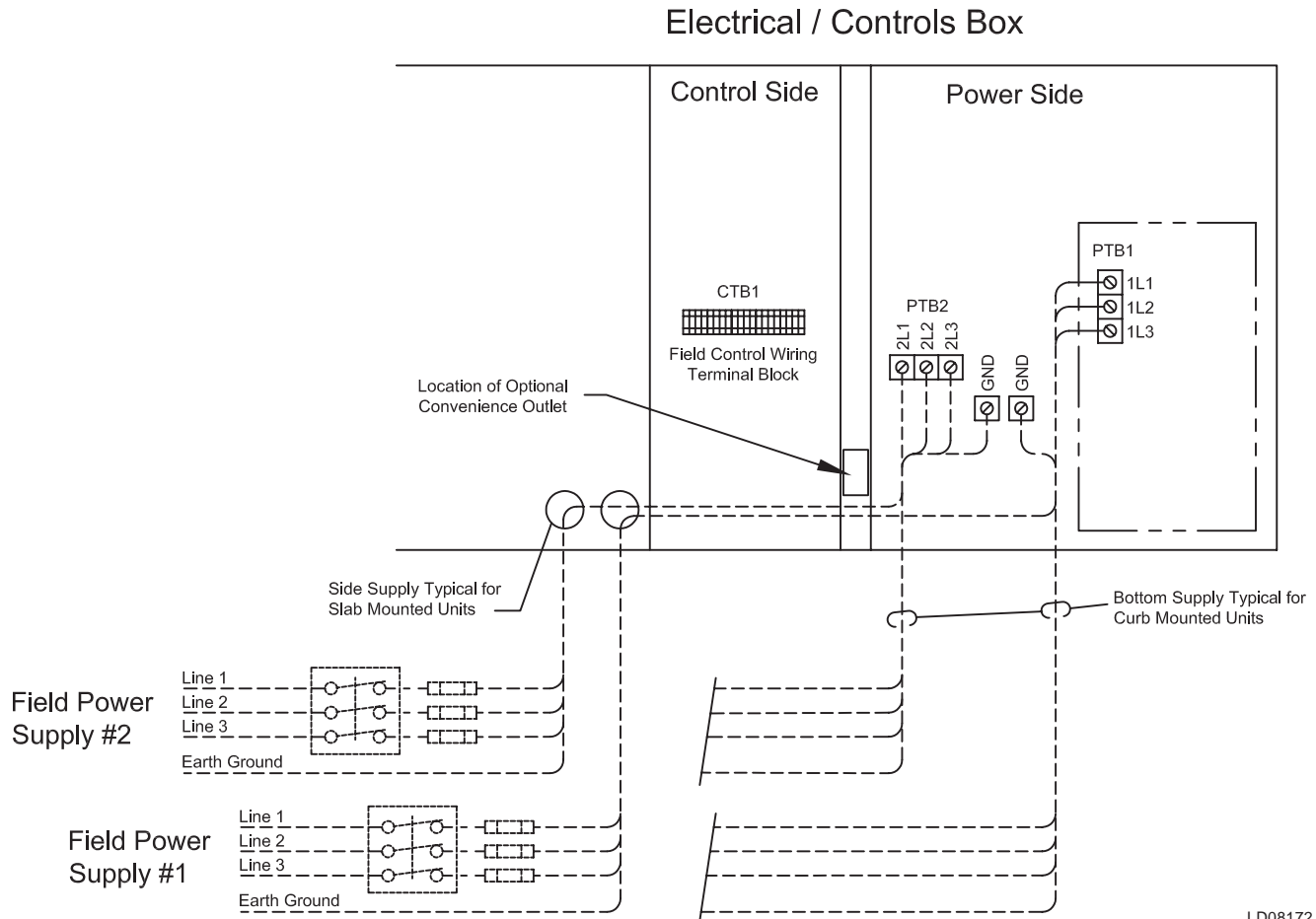

NOTES:

1. All field wiring must be provided through a field-supplied fused disconnect switch to the unit terminals (or optional molded disconnect switch).
2. All electrical wiring must be made in accordance with all N.E.C. and/or local code requirements.
3. Consult the I.O.M manual or unit nameplate data to determine Minimum Circuit Ampacities (MCA) and recommended Dual Element fuse sizes.
4. Minimum Circuit Ampacity (MCA) is based on U.L. Standard 1995, Section 36.14 (N.E.C. Section 440.34).
5. Maximum Dual Element Fuse size is based on U.L. Standard 1995, Section 36.15 (N.E.C. Section 440.22)
6. The "Incoming Wire Range" is the minimum and maximum wire sizes that can be accommodated by the unit wiring lugs. A (2) preceding the wire range indicates the number of termination points available per phase of the wire range specified. Actual wire size and number of wires per phase must be determined based on N.E.C.
7. Use copper conductors only.
8. On units with an optional disconnect switch, the supplied disconnect switch is a "Disconnecting Means" as defined in the N.E.C. Section 100, and is intended for isolating the unit from the available power supply to perform maintenance and troubleshooting. This disconnect switch is not intended to be a Load Break Device.

FIG. 4 – SINGLE-POINT POWER SUPPLY WIRING WITH NON-FUSED DISCONNECT

Power Wiring: YPAL050-105 (continued)

SINGLE-POINT POWER SUPPLY WIRING

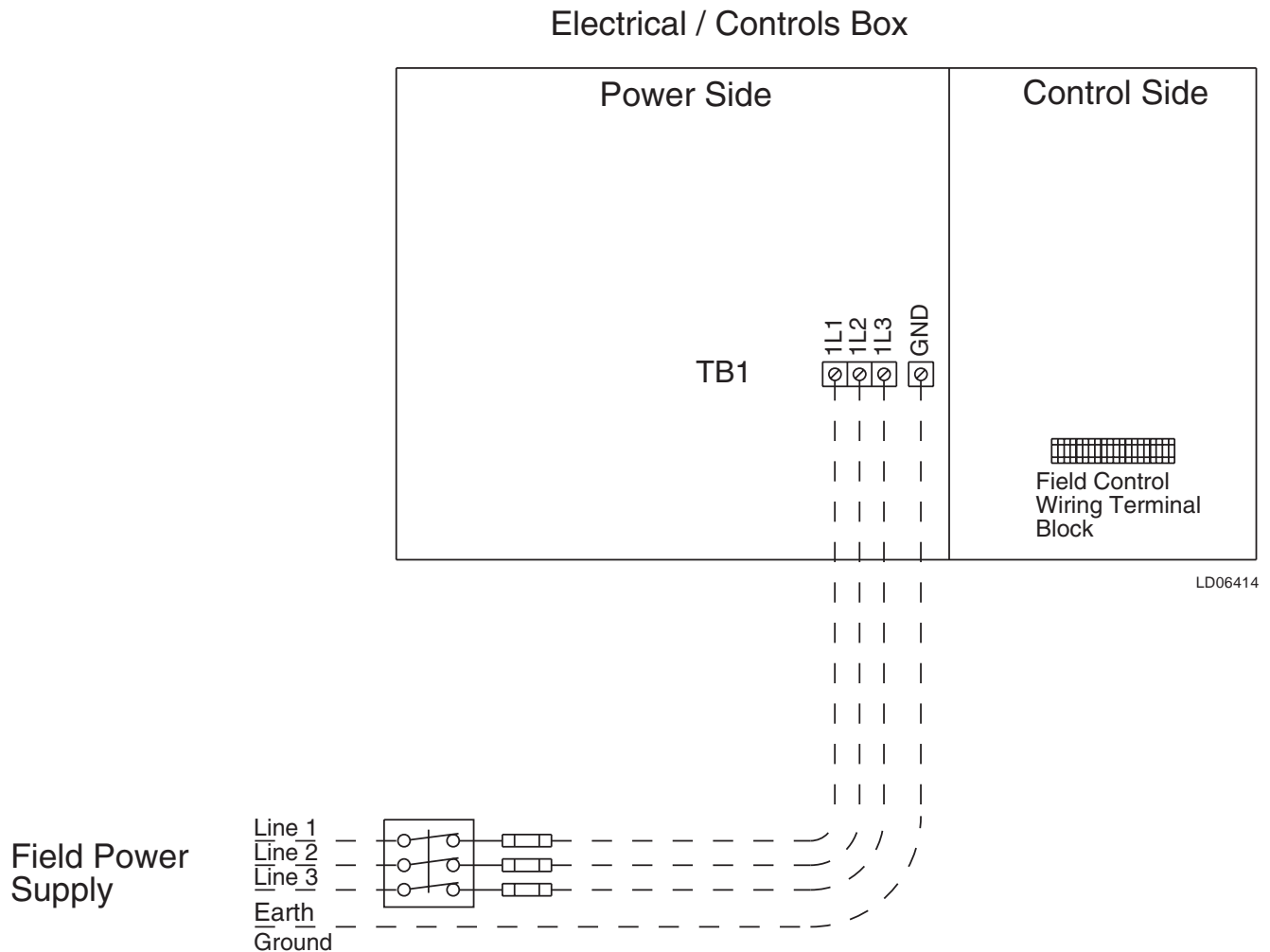

NOTES:

1. All field wiring must be provided through a field-supplied fused disconnect switch to the unit terminals (or optional molded disconnect switch).
2. All electrical wiring must be made in accordance with all N.E.C. and/or local code requirements.
3. Minimum Circuit Ampacity (MCA) is based on U.L. Standard 1995, Section 36.14 (N.E.C. Section 440.34).
4. Maximum Dual Element Fuse size is based on U.L. Standard 1995, Section 36.15 (N.E.C. Section 440.22)
5. Use copper conductors only.
6. On units with an optional disconnect switch, the supplied disconnect switch is a "Disconnecting Means" as defined in the N.E.C. Section 100, and is intended for isolating the unit from the available power supply to perform maintenance and troubleshooting. This disconnect switch is not intended to be a Load Break Device.

FIG. 5 – SINGLE-POINT POWER SUPPLY WIRING

Power Wiring: YPAL050-105 (continued)

SINGLE-POINT POWER SUPPLY WIRING WITH NON-FUSED DISCONNECT

Electrical / Controls Box

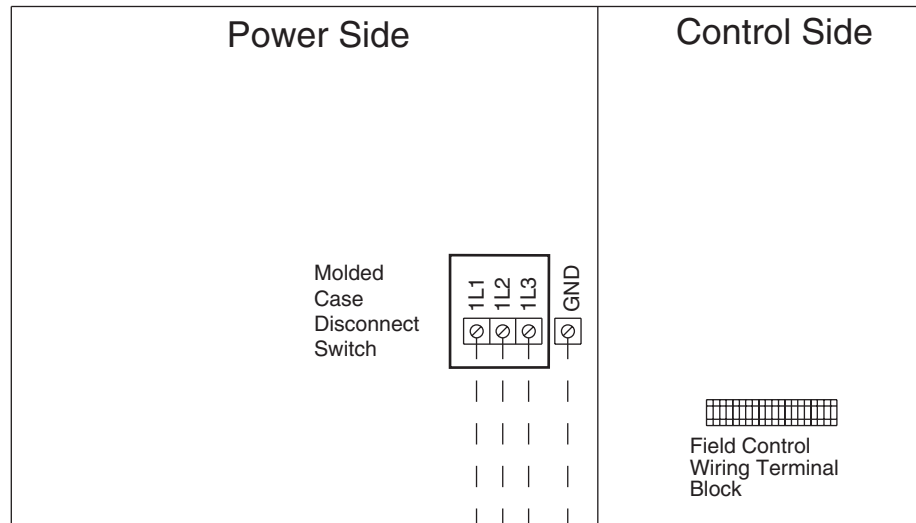

LD06415

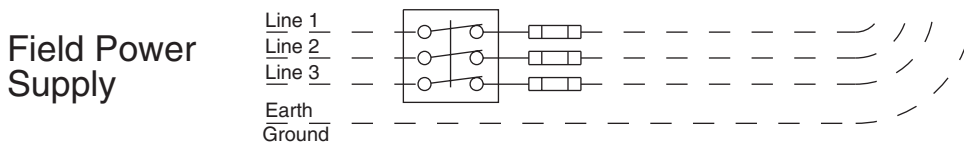

NOTES:

1. All field wiring must be provided through a field-supplied fused disconnect switch to the unit terminals (or optional molded disconnect switch).
2. All electrical wiring must be made in accordance with all N.E.C. and/or local code requirements.
3. Minimum Circuit Ampacity (MCA) is based on U.L. Standard 1995, Section 36.14 (N.E.C. Section 440.34).
4. Maximum Dual Element Fuse size is based on U.L. Standard 1995, Section 36.15 (N.E.C. Section 440.22)
5. Use copper conductors only.
6. On units with an optional disconnect switch, the supplied disconnect switch is a "Disconnecting Means" as defined in the N.E.C. Section 100, and is intended for isolating the unit from the available power supply to perform maintenance and troubleshooting. This disconnect switch is not intended to be a Load Break Device.

FIG. 6 – SINGLE-POINT POWER SUPPLY WIRING WITH NON-FUSED DISCONNECT

Power Wiring: YPAL050-105 (continued)

DUAL-POINT POWER SUPPLY WIRING

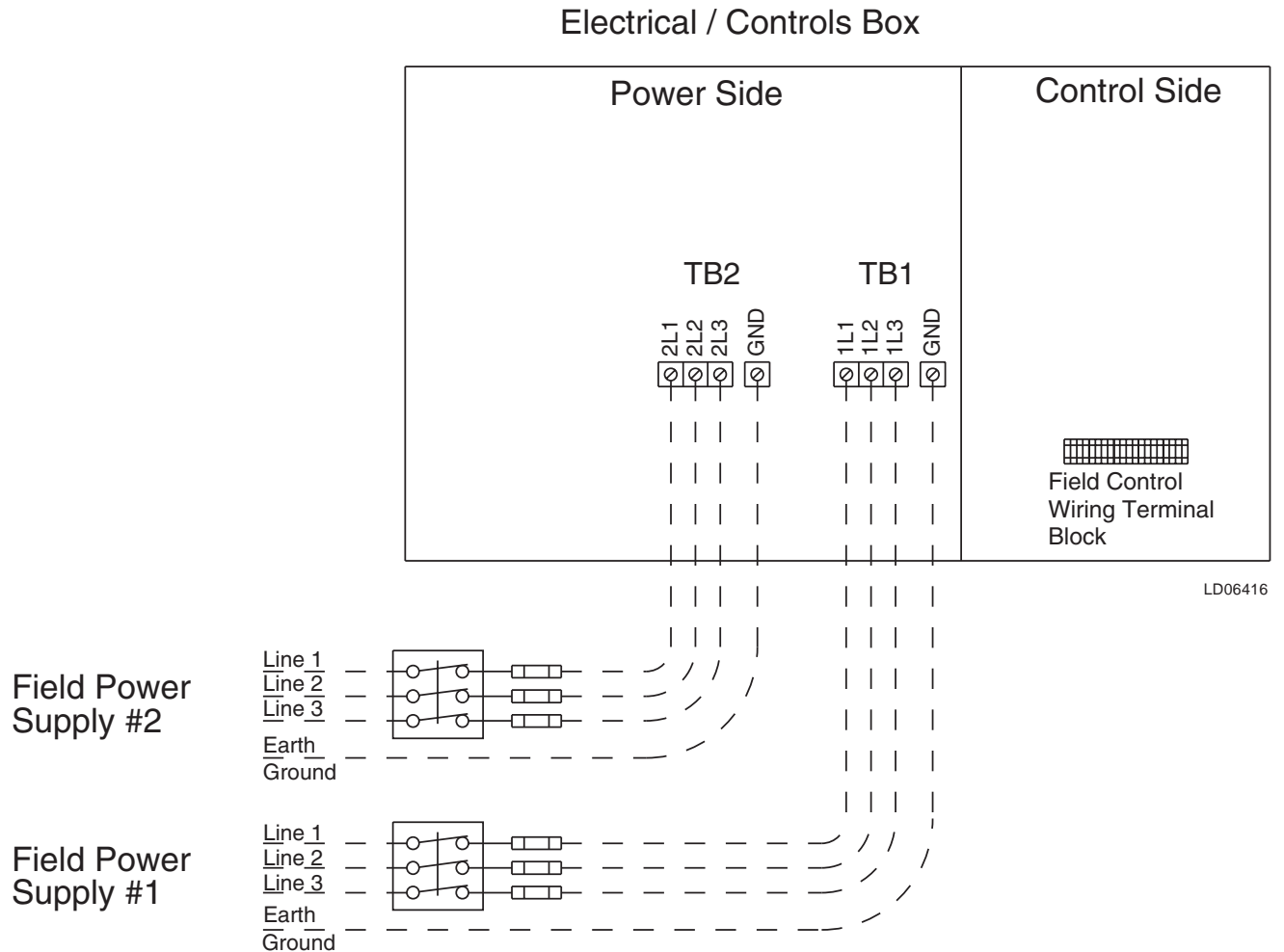

NOTES:

1. All field wiring must be provided through a field-supplied fused disconnect switch to the unit terminals (or optional molded disconnect switch).
2. All electrical wiring must be made in accordance with all N.E.C. and/or local code requirements.
3. Minimum Circuit Ampacity (MCA) is based on U.L. Standard 1995, Section 36.14 (N.E.C. Section 440.34).
4. Maximum Dual Element Fuse size is based on U.L. Standard 1995, Section 36.15 (N.E.C. Section 440.22)
5. Use copper conductors only.
6. On units with an optional disconnect switch, the supplied disconnect switch is a "Disconnecting Means" as defined in the N.E.C. Section 100, and is intended for isolating the unit from the available power supply to perform maintenance and troubleshooting. This disconnect switch is not intended to be a Load Break Device.

FIG. 7 – DUAL-POINT POWER SUPPLY WIRING

Field Control Wiring

Wiring Notes:

1. Wiring shown indicates typical wiring. Refer to the I.O.M. manual for more detailed wiring methods and options.
2. All wiring is Class 2, low voltage.
3. Maximum power available from the 24 VAC terminal is 40 VA.
4. Use shielded wire where shown.
5. Potentiometer application shown. As an alternative, signal inputs can be driven from an analog output of a third party controller. Note: Input load resistance is 15K ohms.

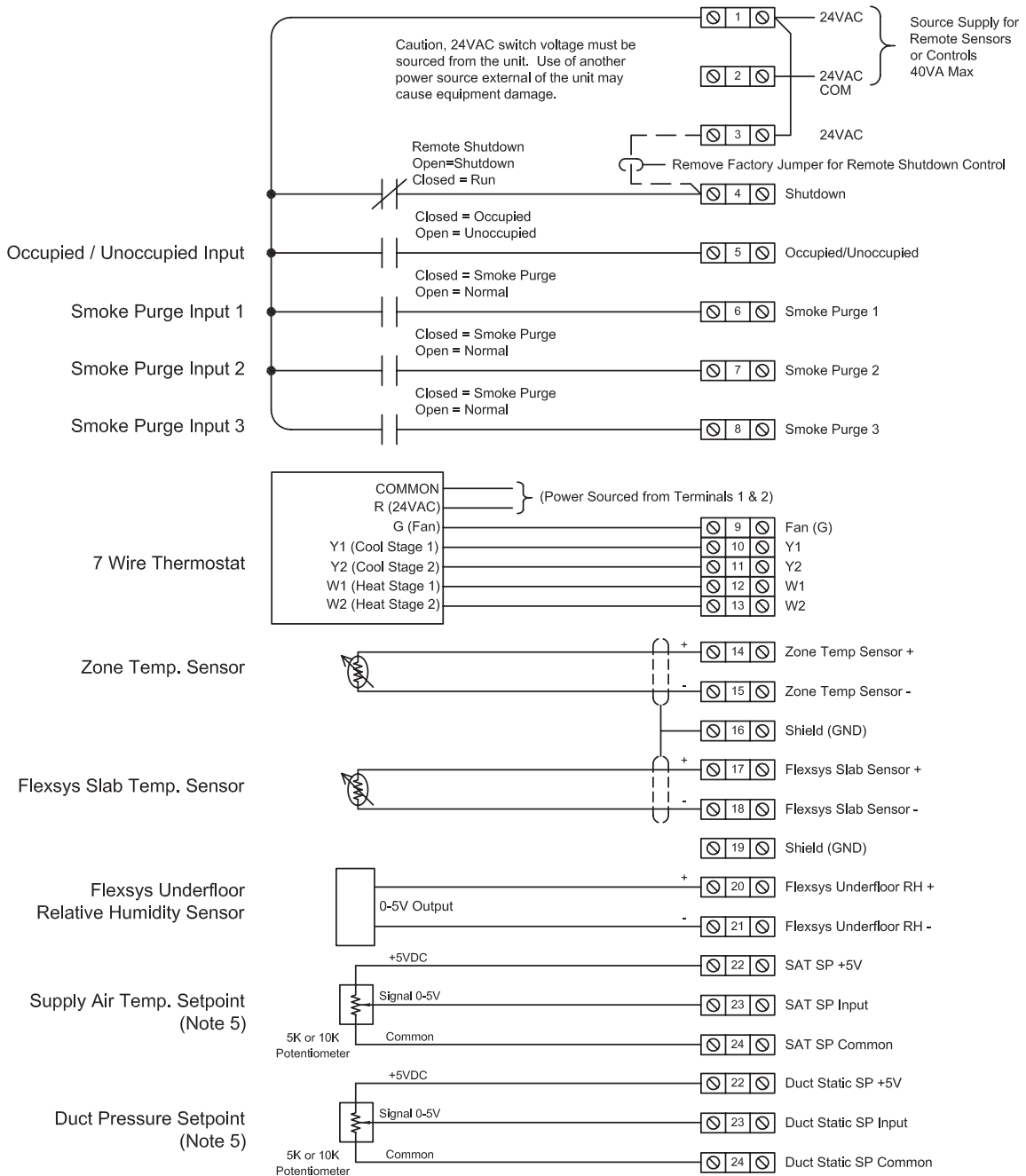

LD08184

FIG. 8 – FIELD CONTROL WIRING

Wiring Notes:

1. Wiring shown indicates typical wiring. Refer to the I.O.M. manual for more detailed wiring methods and options.
2. All wiring is Class 2, low voltage.
3. Maximum power available from the 24 VAC terminal is 40 VA.
4. Use shielded wire where shown.
5. Relay contacts suitable for pilot duty to 1A from 24VAC to 120VAC

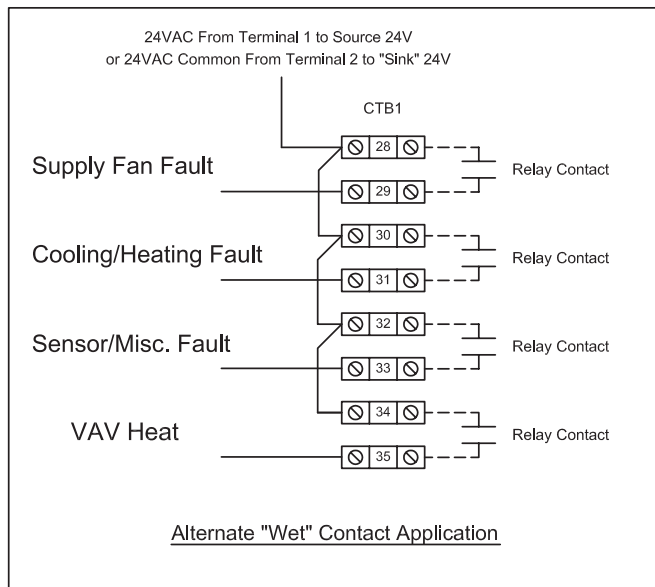
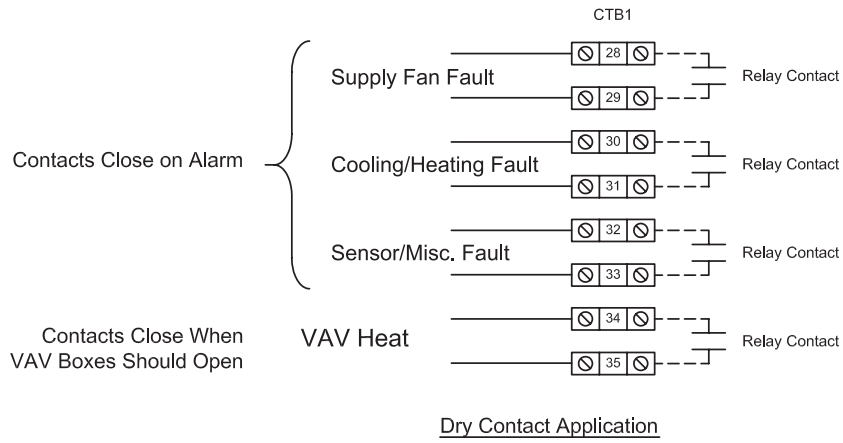

LD08186

FIG. 9 – FIELD CONTROL WIRING

General Arrangement Drawing – 50-65 Ton Models

BOTTOM SUPPLY / BOTTOM RETURN

SECTION DESCRIPTIONS:

- EE = Economizer
- FE = Fan Exhaust
- MB = Mixing Box
- F = Filter Segments
- CC = Cooling Coils
- FS = Supply Fan
- DP = Discharge Plenum
- CO = Condenser Section
- CP = Control Panel

- ### NOTES:
1. 10" Clearance Minimal Over The Top of the Condensing Unit.
 2. Only One Adjacent Wall Can Exceed Unit Height.
 3. 12" Clearance Required to Adjacent Units
 4. 8" Service Access Recommended on One Side.
 5. Economizer and Exhaust Hoods, Where Applicable, are Folded Inside Unit for Shipment.

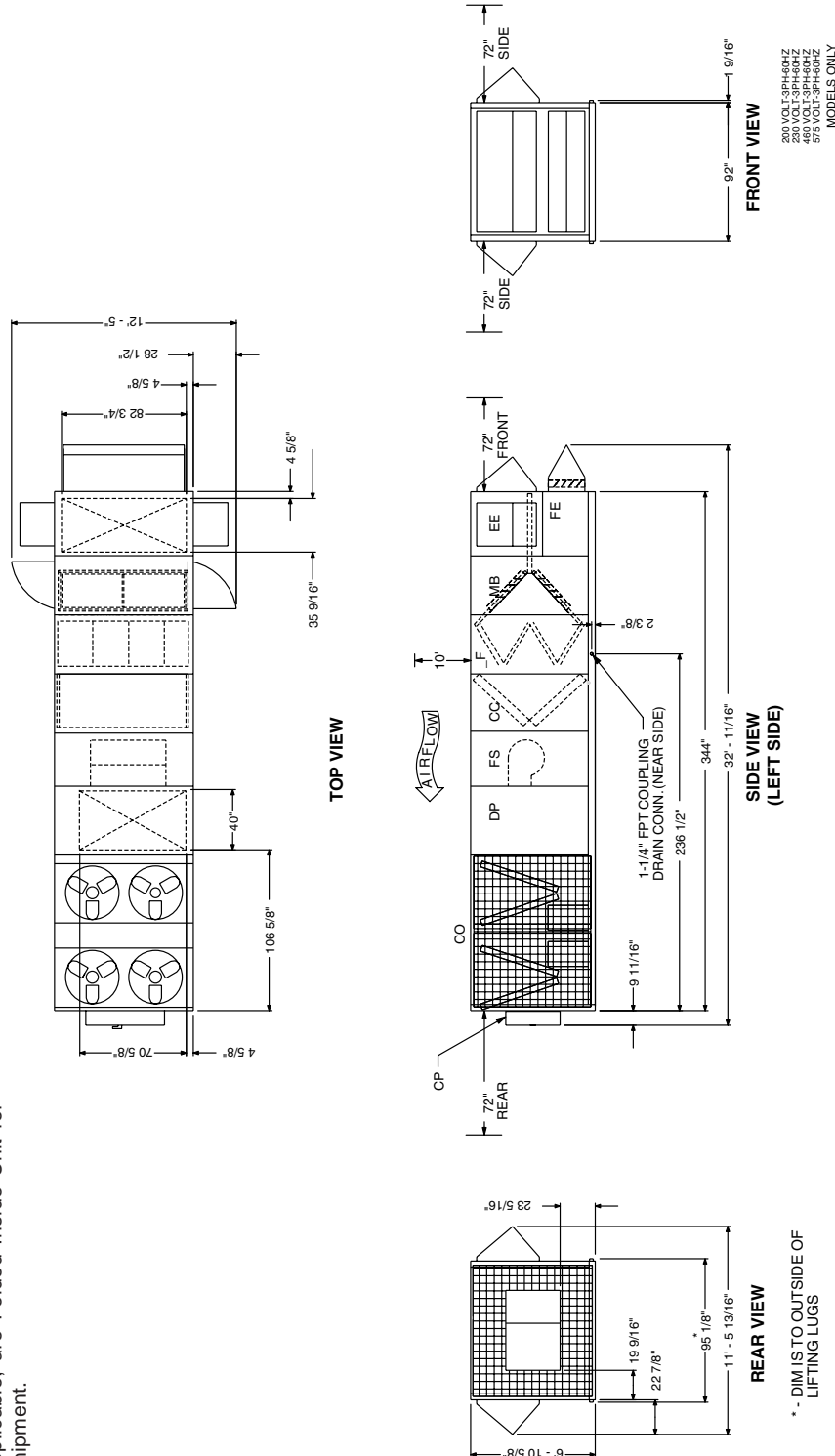

FIG. 10 – GENERAL ARRANGEMENT DRAWING

LD08126

LEFT SUPPLY / FRONT RETURN

SECTION DESCRIPTIONS:

- EE = Economizer
- FE = Fan Exhaust
- MB = Mixing Box
- F = Filter Segments
- CC = Cooling Coils
- FS = Supply Fan
- DP = Discharge Plenum
- CO = Condenser Section
- CP = Control Panel

- NOTES:**
1. 10' Clearance Minimal Over The Top of the Condensing Unit.
 2. Only One Adjacent Wall Can Exceed Unit Height.
 3. 12' Clearance Required to Adjacent Units
 4. 8' Service Access Recommended on One Side.
 5. Economizer and Exhaust Hoods, Where Applicable, are Folded Inside Unit for Shipment.

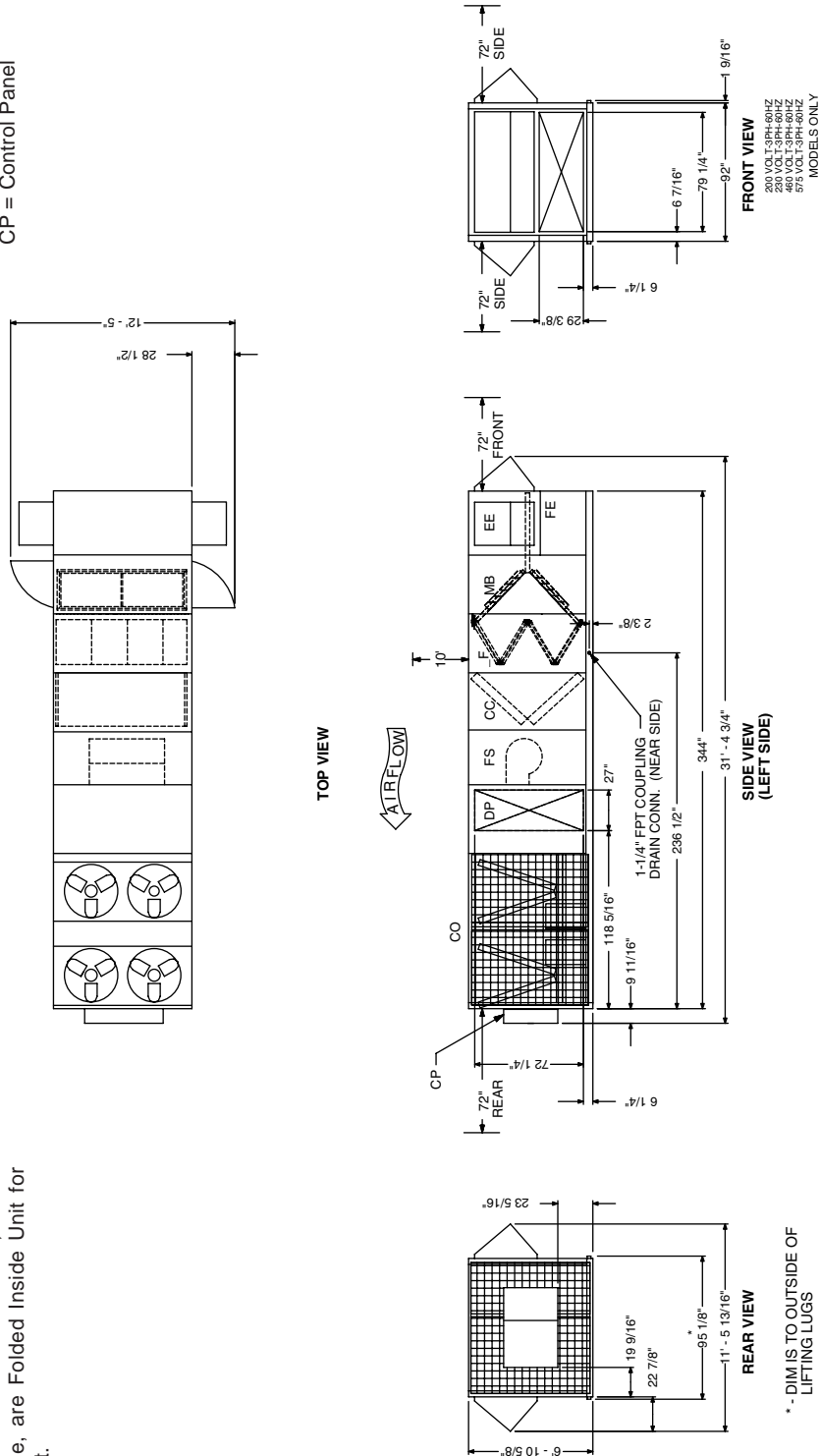

FIG. 10 – GENERAL ARRANGEMENT DRAWING

General Arrangement Drawing – 70-85 Ton Models

BOTTOM SUPPLY / BOTTOM RETURN

SECTION DESCRIPTIONS:

- EE = Economizer
- FE = Fan Exhaust
- MB = Mixing Box
- _F = Filter Segments
- CC = Cooling Coils
- FS = Supply Fan
- DP = Discharge Plenum
- CO = Condenser Section
- CP = Control Panel

- ### NOTES:
1. 10' Clearance Minimal Over The Top of the Condensing Unit.
 2. Only One Adjacent Wall Can Exceed Unit Height.
 3. 12' Clearance Required to Adjacent Units
 4. 8' Service Access Recommended on One Side.
 5. Economizer and Exhaust Hoods, Where Applicable, are Folded Inside Unit for Shipment.

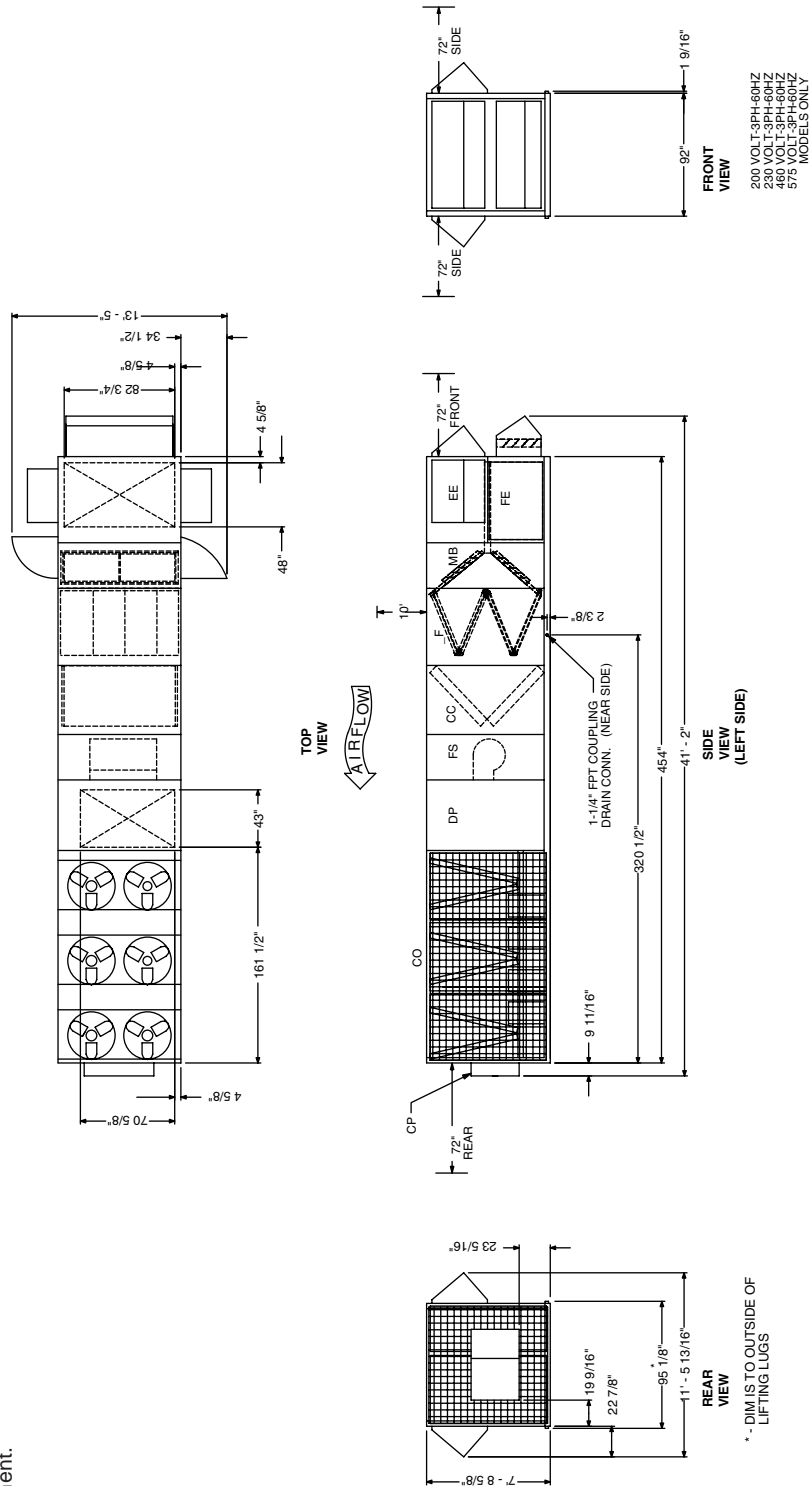

FIG. 10 – GENERAL ARRANGEMENT DRAWING

LD08128

LEFT SUPPLY / LEFT RETURN

SECTION DESCRIPTIONS:

- EE = Economizer
- FE = Fan Exhaust
- MB = Mixing Box
- F = Filter Segments
- CC = Cooling Coils
- FS = Supply Fan
- DP = Discharge Plenum
- CO = Condenser Section
- CP = Control Panel

- NOTES:**
1. 10' Clearance Minimal Over The Top of the Condensing Unit.
 2. Only One Adjacent Wall Can Exceed Unit Height.
 3. 12' Clearance Required to Adjacent Units
 4. 8' Service Access Recommended on One Side.
 5. Economizer and Exhaust Hoods, Where Applicable, are Folded Inside Unit for Shipment.

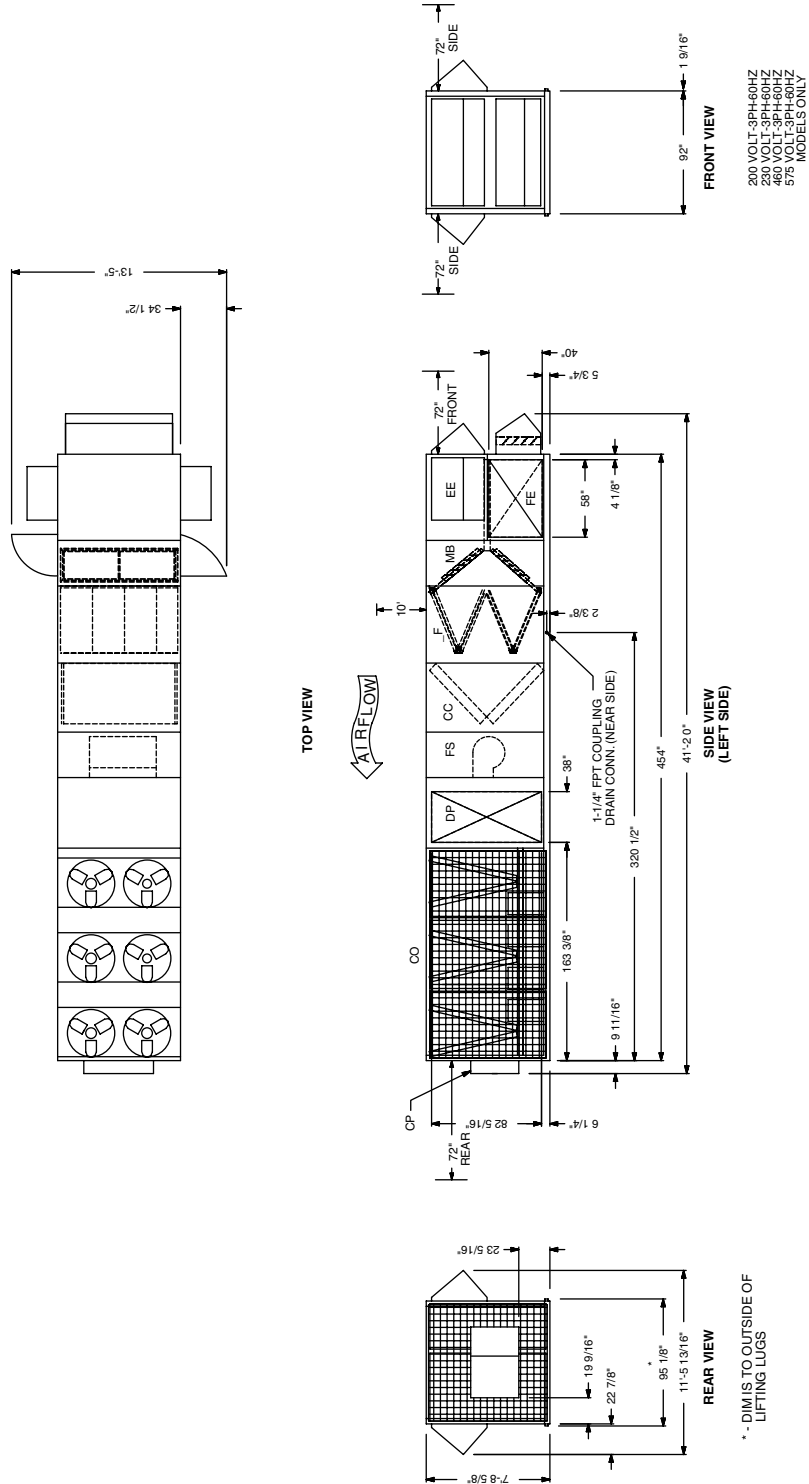

200 VOLT-3PH-60HZ
 230 VOLT-3PH-60HZ
 460 VOLT-3PH-60HZ
 575 VOLT-3PH-60HZ
 MODELS ONLY

FIG. 10 – GENERAL ARRANGEMENT DRAWING

General Arrangement Drawing – 70-85 Ton Models

LEFT SUPPLY / FRONT RETURN

SECTION DESCRIPTIONS:

- EE = Economizer
- FE = Fan Exhaust
- MB = Mixing Box
- F = Filter Segments
- CC = Cooling Coils
- FS = Supply Fan
- DP = Discharge Plenum
- CO = Condenser Section
- CP = Control Panel

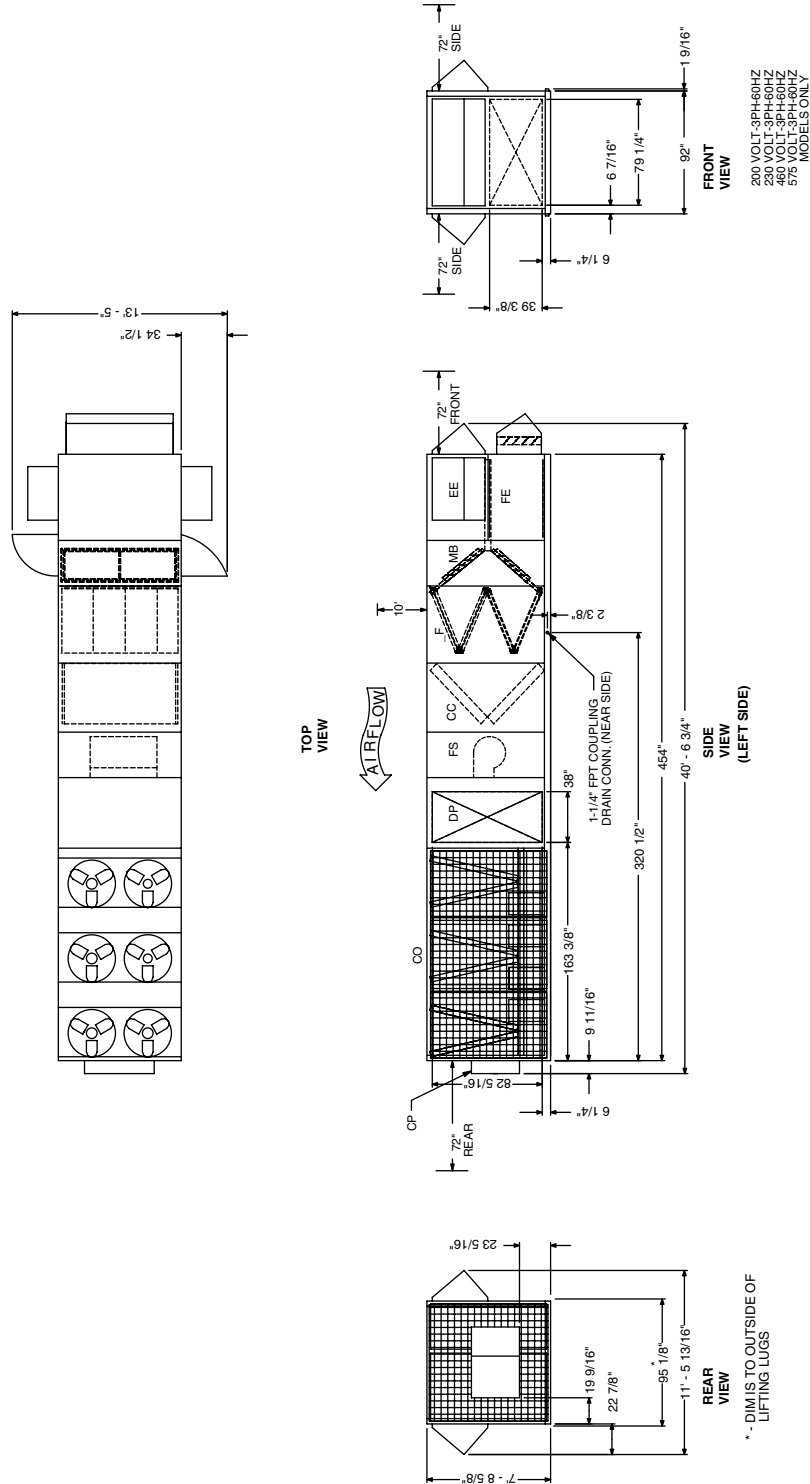

NOTES:

1. 10' Clearance Minimal Over The Top of the Condensing Unit.
2. Only One Adjacent Wall Can Exceed Unit Height.
3. 12' Clearance Required to Adjacent Units
4. 8' Service Access Recommended on One Side.
5. Economizer and Exhaust Hoods, Where Applicable, are Folded Inside Unit for Shipment.

FIG. 10 – GENERAL ARRANGEMENT DRAWING

General Arrangement Drawing – 90-105 Ton Models

BOTTOM SUPPLY / BOTTOM RETURN

SECTION DESCRIPTIONS:

- EE = Economizer
- FE = Fan Exhaust
- MB = Mixing Box
- F = Filter Segments
- CC = Cooling Coils
- FS = Supply Fan
- DP = Discharge Plenum
- CO = Condenser Section
- CP = Control Panel

- ### NOTES:
1. 10' Clearance Minimal Over The Top of the Condensing Unit.
 2. Only One Adjacent Wall Can Exceed Unit Height.
 3. 12' Clearance Required to Adjacent Units
 4. 8' Service Access Recommended on One Side.
 5. Economizer and Exhaust Hoods, Where Applicable, are Folded Inside Unit for Shipment.

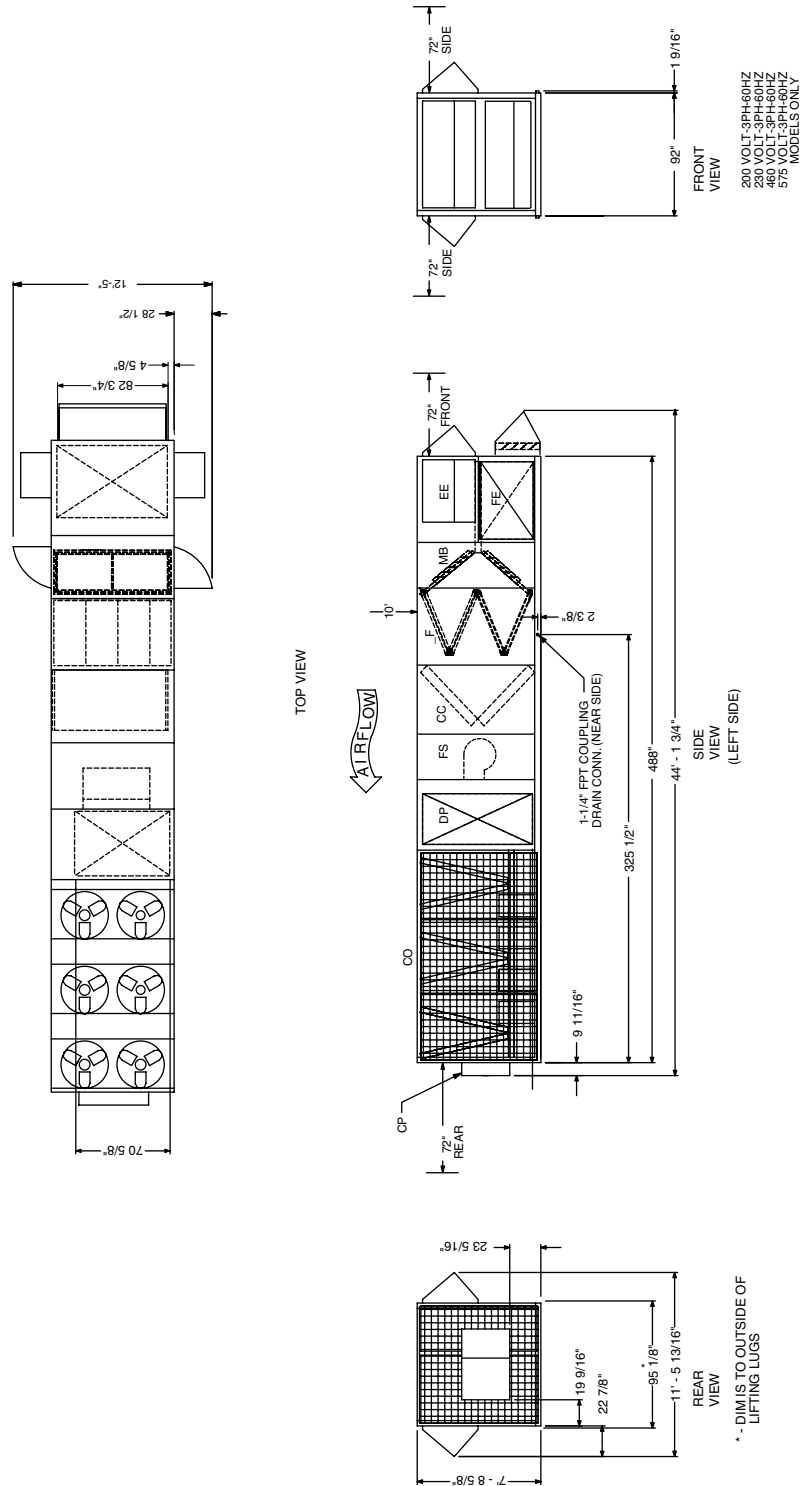

FIG. 10 – GENERAL ARRANGEMENT DRAWING

General Arrangement Drawing — 90-105 Ton Models

LEFT SUPPLY / LEFT RETURN

SECTION DESCRIPTIONS:

- EE = Economizer
- FE = Fan Exhaust
- MB = Mixing Box
- F = Filter Segments
- CC = Cooling Coils
- FS = Supply Fan
- DP = Discharge Plenum
- CO = Condenser Section
- CP = Control Panel

NOTES:

1. 10' Clearance Minimal Over The Top of the Condensing Unit.
2. Only One Adjacent Wall Can Exceed Unit Height.
3. 12' Clearance Required to Adjacent Units
4. 8' Service Access Recommended on One Side.
5. Economizer and Exhaust Hoods, Where Applicable, are Folded Inside Unit for Shipment.

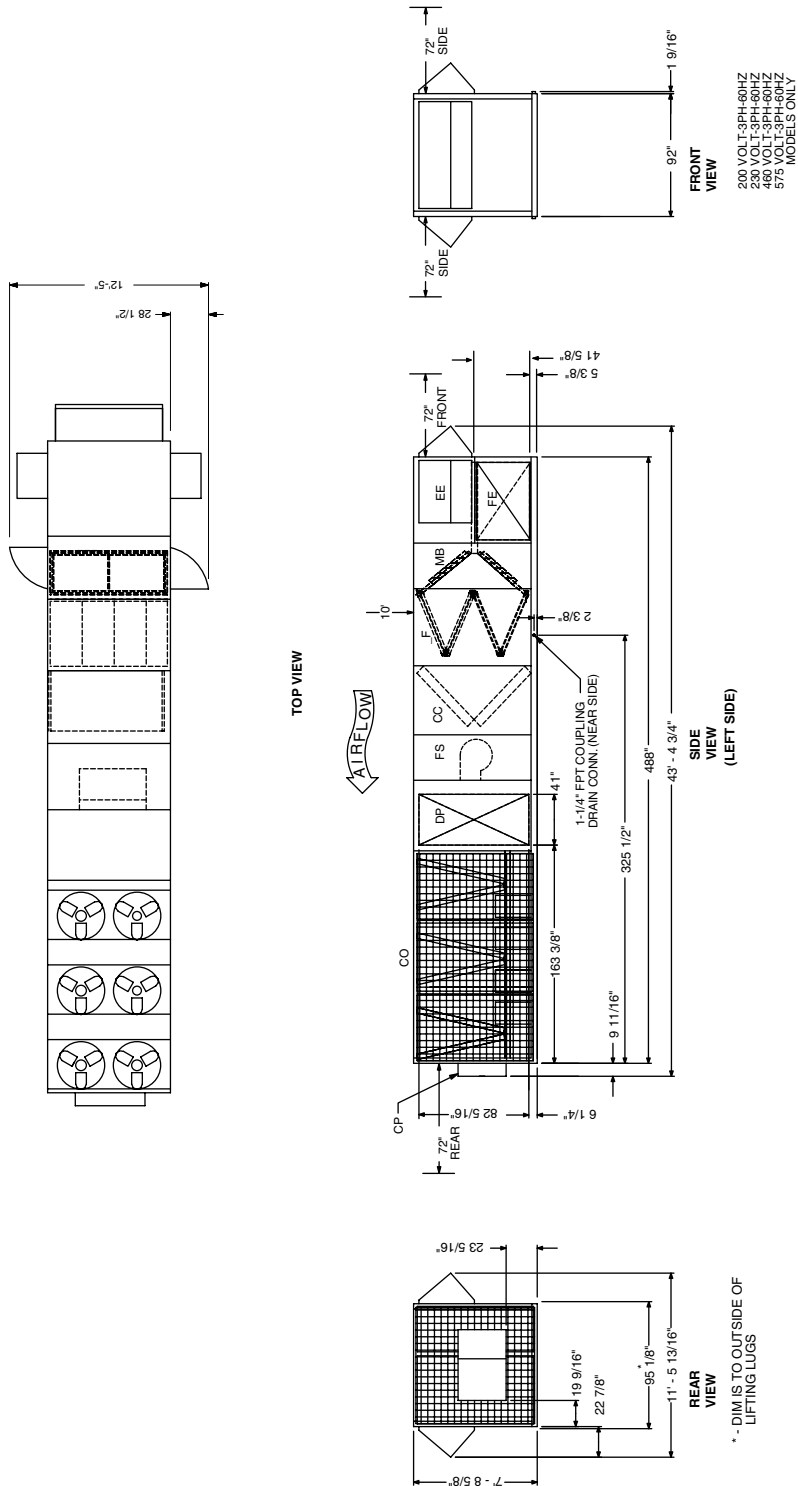

FIG. 10 – GENERAL ARRANGEMENT DRAWING

LD08132

LEFT SUPPLY / FRONT RETURN

SECTION DESCRIPTIONS:

- EE = Economizer
- FE = Fan Exhaust
- MB = Mixing Box
- F = Filter Segments
- CC = Cooling Coils
- FS = Supply Fan
- DP = Discharge Plenum
- CO = Condenser Section
- CP = Control Panel

- NOTES:**
1. 10' Clearance Minimal Over The Top of the Condensing Unit.
 2. Only One Adjacent Wall Can Exceed Unit Height.
 3. 12' Clearance Required to Adjacent Units
 4. 8' Service Access Recommended on One Side.
 5. Economizer and Exhaust Hoods, Where Applicable, are Folded Inside Unit for Shipment.

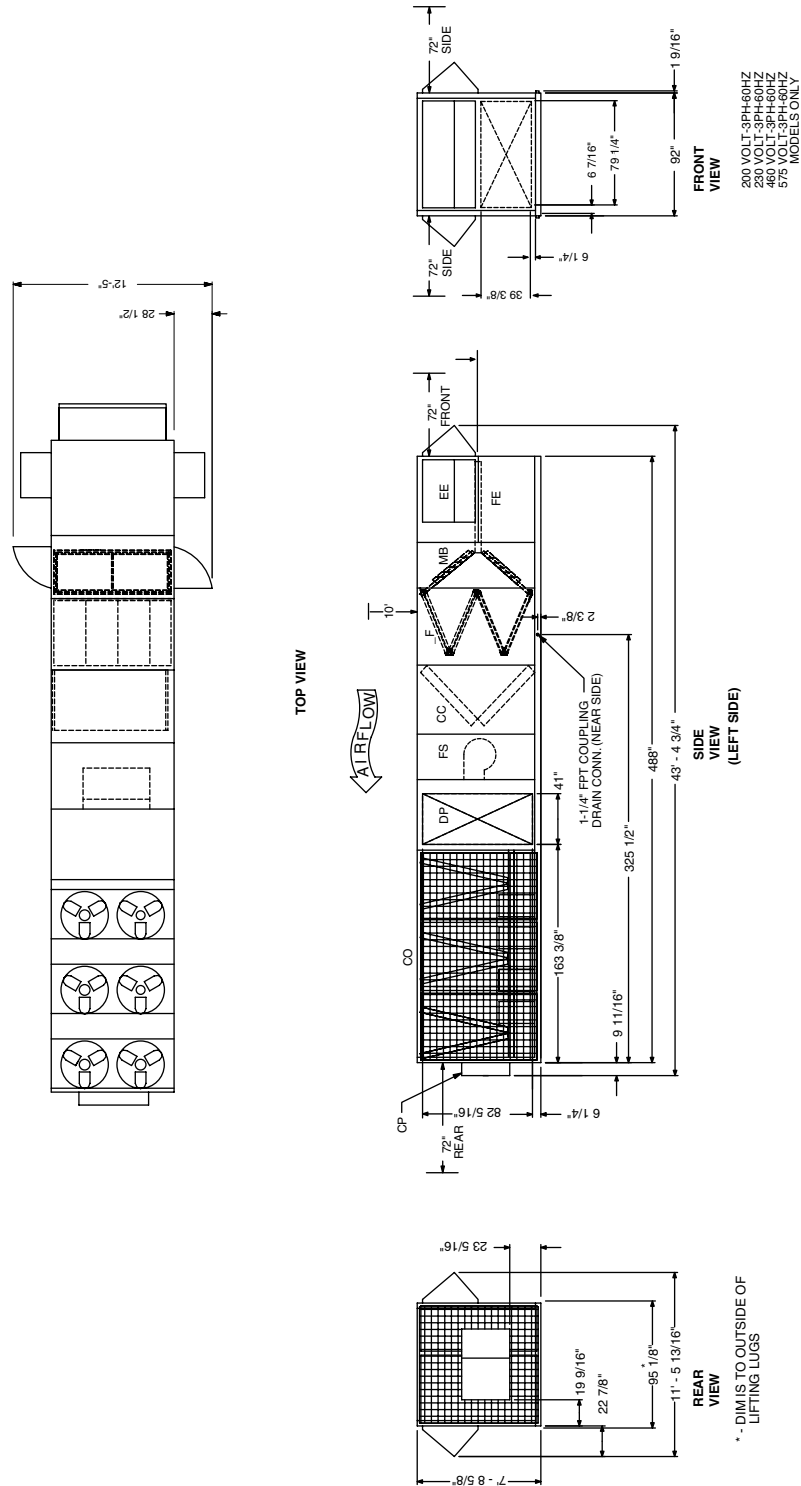

FIG. 10 – GENERAL ARRANGEMENT DRAWING

General Arrangement Drawing – 90-105 Ton Models

EXTENDED CABINET / BOTTOM SUPPLY / BOTTOM RETURN

SECTION DESCRIPTIONS:

- EE = Economizer
- FE = Fan Exhaust
- MB = Mixing Box
- _F = Filter Segments
- CC = Cooling Coils
- FS = Supply Fan
- FF = Final Filter
- DP = Discharge Plenum
- CO = Condenser Section
- CP = Control Panel

NOTES:

1. 10' Clearance Minimal Over The Top of the Condensing Unit.
2. Only One Adjacent Wall Can Exceed Unit Height.
3. 12' Clearance Required to Adjacent Units
4. 8' Service Access Recommended on One Side.
5. Economizer and Exhaust Hoods, Where Applicable, are Folded Inside Unit for Shipment.
6. Clearance Downstream of the Diffuser. If the Diffuser Factory Option is Not Installed, Clearance, Downstream of the Supply Fan Outlet is Required to Provide Adequate Air Flow and Reduce Air Pressure Drop.

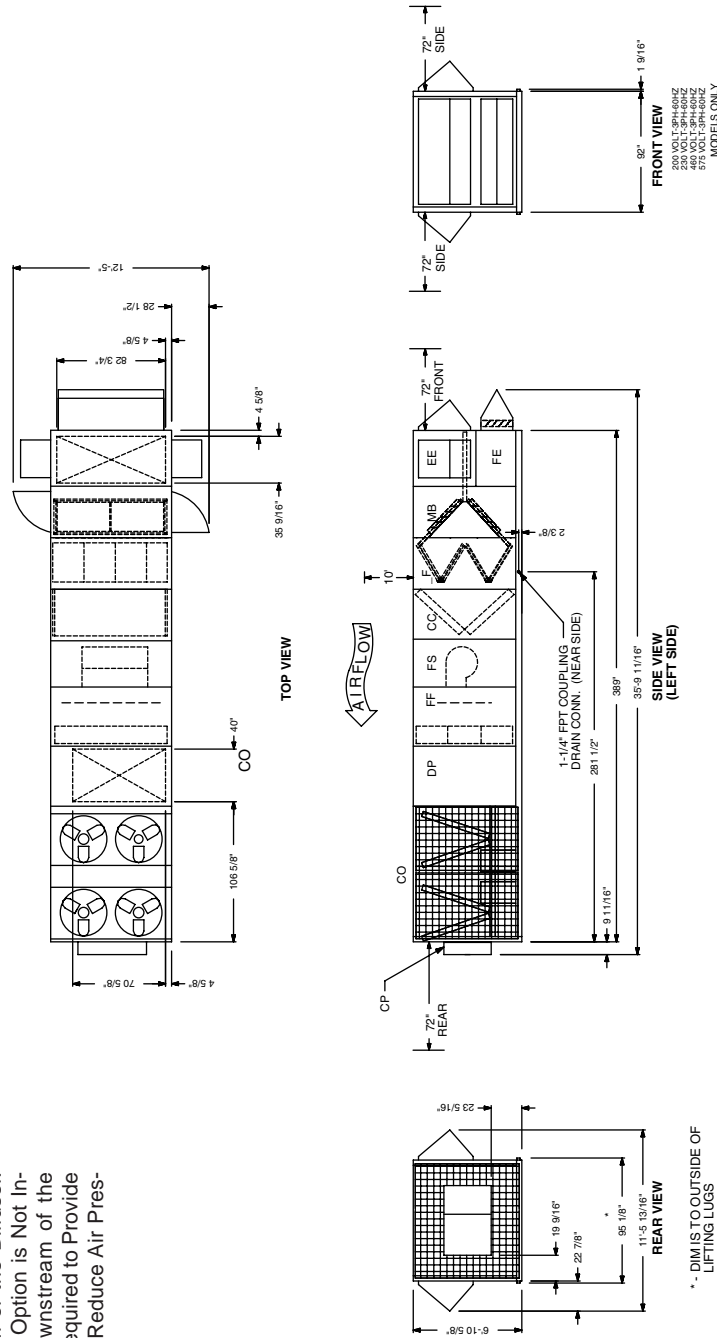

FIG. 10 – GENERAL ARRANGEMENT DRAWING

LD08134

General Arrangement Drawing – 50-65 Ton Models

EXTENDED CABINET / LEFT SUPPLY / FRONT RETURN

SECTION DESCRIPTIONS:

- EE = Economizer
- FE = Fan Exhaust
- MB = Mixing Box
- F = Filter Segments
- CC = Cooling Coils
- FS = Supply Fan
- FF = Final Filter
- DP = Discharge Plenum
- CO = Condenser Section
- CP = Control Panel

NOTES:

1. 10' Clearance Minimal Over The Top of the Condensing Unit.
2. Only One Adjacent Wall Can Exceed Unit Height.
3. 12' Clearance Required to Adjacent Units
4. 8' Service Access Recommended on One Side.
5. Economizer and Exhaust Hoods, Where Applicable, are Folded Inside Unit for Shipment.
6. Clearance Downstream of the Diffuser. If the Diffuser Factory Option is Not Installed, Clearance, Downstream of the Supply Fan Outlet is Required to Provide Adequate Air Flow and Reduce Air Pressure Drop.

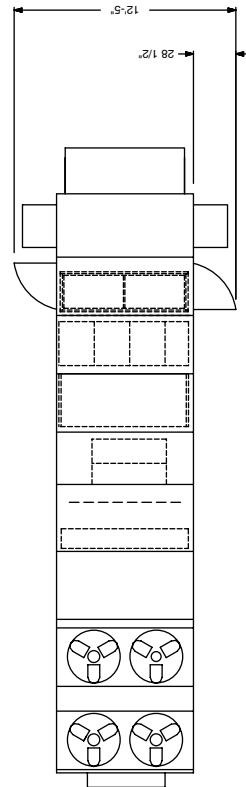

TOP VIEW

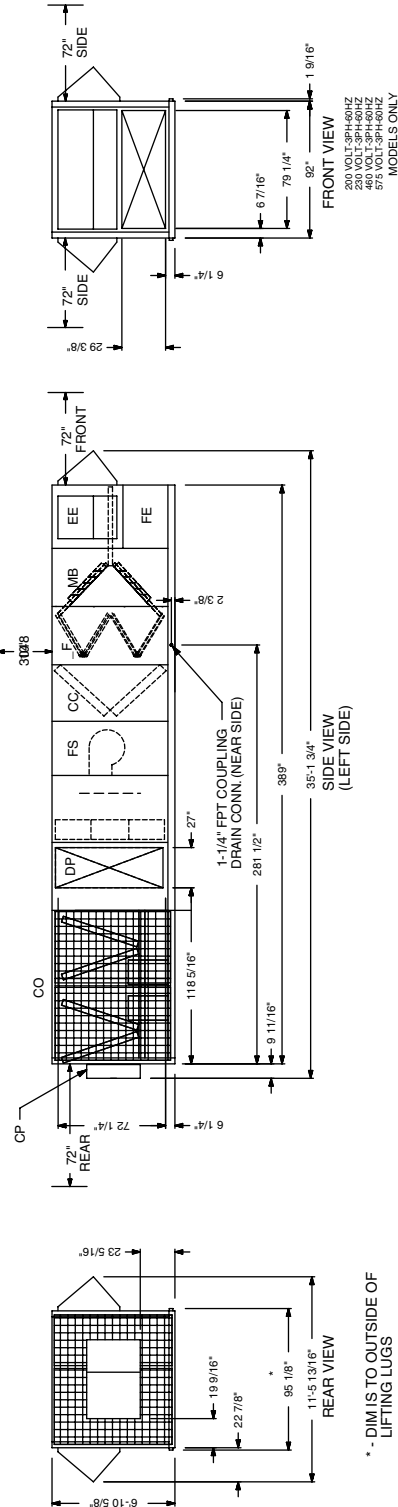

FRONT VIEW
200 VOLT-3PH-60HZ
480 VOLT-3PH-60HZ
575 VOLT-3PH-60HZ
MODELS ONLY

* - DIM IS TO OUTSIDE OF LIFTING LUGS

FIG. 10 – GENERAL ARRANGEMENT DRAWING

General Arrangement Drawing – 70-85 Ton Models

EXTENDED CABINET / BOTTOM SUPPLY / BOTTOM RETURN

SECTION DESCRIPTIONS:

- EE = Economizer
- FE = Fan Exhaust
- MB = Mixing Box
- F = Filter Segments
- CC = Cooling Coils
- FS = Supply Fan
- DP = Discharge Plenum
- CO = Condenser Section
- CP = Control Panel

- NOTES:**
- 10' Clearance Minimal Over The Top of the Condensing Unit.
 - Only One Adjacent Wall Can Exceed Unit Height.
 - 12' Clearance Required to Adjacent Units
 - 8' Service Access Recommended on One Side.
 - Economizer and Exhaust Hoods, Where Applicable, are Folded Inside Unit for Shipment.
 - Clearance Downstream of the Diffuser. If the Diffuser Factory Option is Not Installed, Clearane, Downstream of the Supply Fan Outlet is Required to Provide Adequate Air Flow and Reduce Air Pressure Drop.

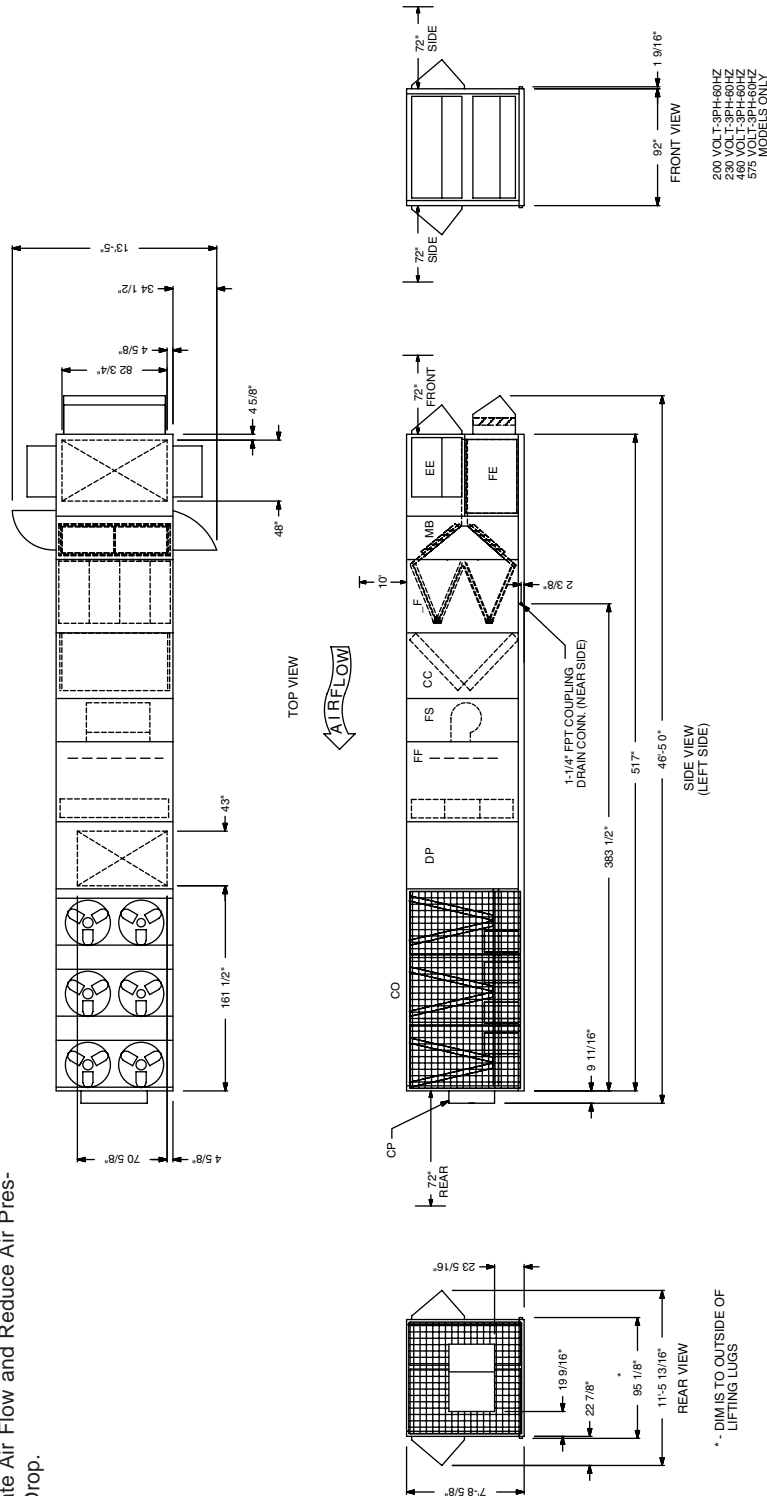

200 VOLT, 3PH, 60HZ
 230 VOLT, 3PH, 60HZ
 480 VOLT, 3PH, 60HZ
 575 VOLT, 3PH, 60HZ
 MODELS ONLY

FIG. 10 – GENERAL ARRANGEMENT DRAWING

LD08138

EXTENDED CABINET / LEFT SUPPLY / LEFT RETURN

SECTION DESCRIPTIONS:

- EE = Economizer
- FE = Fan Exhaust
- MB = Mixing Box
- _F = Filter Segments
- CC = Cooling Coils
- FS = Supply Fan
- FF = Final Filter
- DP = Discharge Plenum
- CO = Condenser Section
- CP = Control Panel

- NOTES:**
1. 10' Clearance Minimal Over The Top of the Condensing Unit.
 2. Only One Adjacent Wall Can Exceed Unit Height.
 3. 12' Clearance Required to Adjacent Units
 4. 8' Service Access Recommended on One Side.
 5. Economizer and Exhaust Hoods, Where Applicable, are Folded Inside Unit for Shipment.
 6. Clearance Downstream of the Diffuser. If the Diffuser Factory Option is Not Installed, Clearane, Downstream of the Supply Fan Outlet is Required to Provide Adequate Air Flow and Reduce Air Pressure Drop.

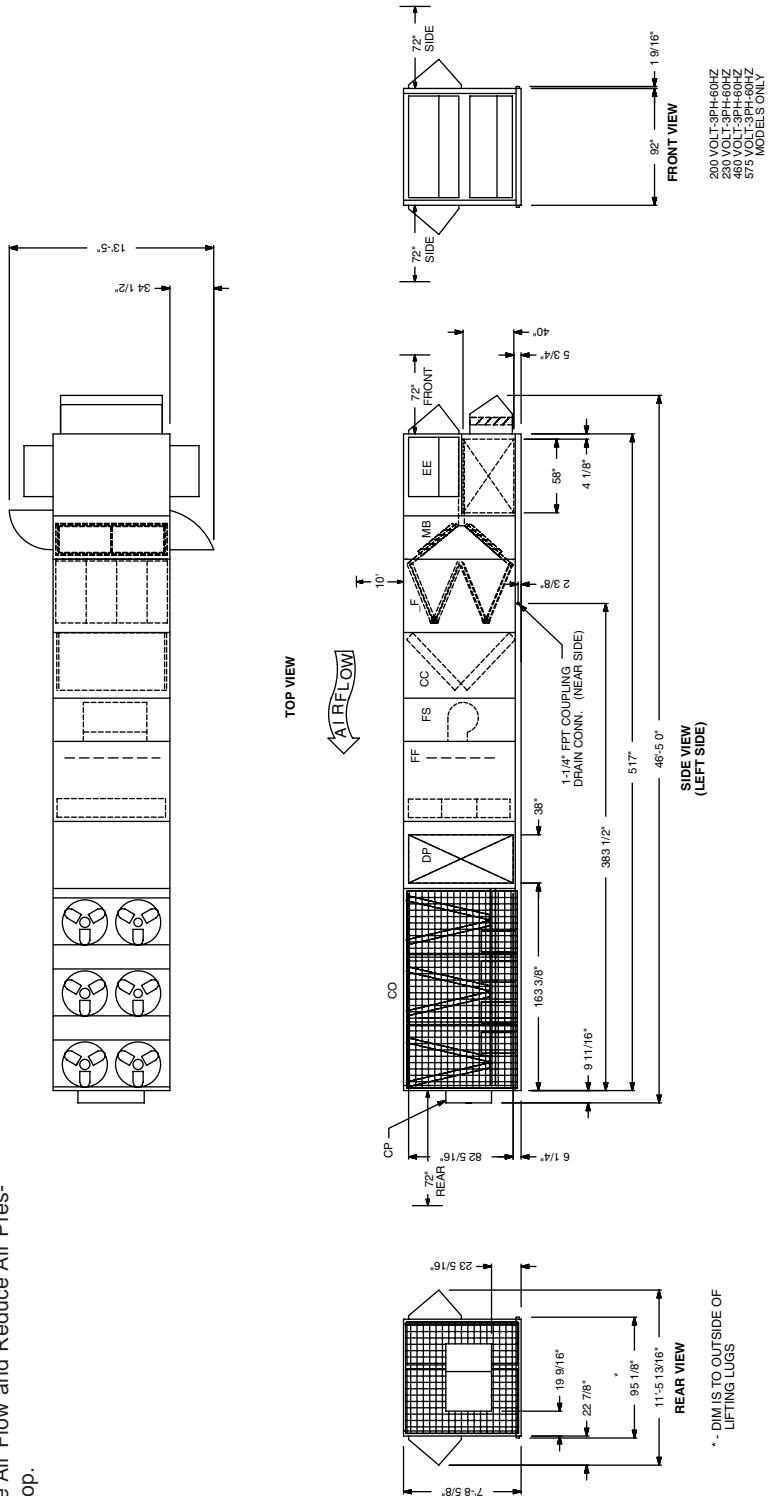

300 VOLT-3PH-60HZ
 200 VOLT-3PH-60HZ
 480 VOLT-3PH-60HZ
 575 VOLT-3PH-60HZ
 MODELS ONLY

FIG. 10 – GENERAL ARRANGEMENT DRAWING

General Arrangement Drawing – 70-85 Ton Models

EXTENDED CABINET / LEFT SUPPLY / FRONT RETURN

SECTION DESCRIPTIONS:

- EE = Economizer
- FE = Fan Exhaust
- MB = Mixing Box
- F = Filter Segments
- CC = Cooling Coils
- FS = Supply Fan
- DP = Discharge Plenum
- CO = Condenser Section
- CP = Control Panel

- NOTES:**
1. 10' Clearance Minimal Over The Top of the Condensing Unit.
 2. Only One Adjacent Wall Can Exceed Unit Height.
 3. 12' Clearance Required to Adjacent Units
 4. 8' Service Access Recommended on One Side.
 5. Economizer and Exhaust Hoods, Where Applicable, are Folded Inside Unit for Shipment.
 6. Clearance Downstream of the Diffuser. If the Diffuser Factory Option is Not Installed, Clearance, Downstream of the Supply Fan Outlet is Required to Provide Adequate Air Flow and Reduce Air Pressure Drop.

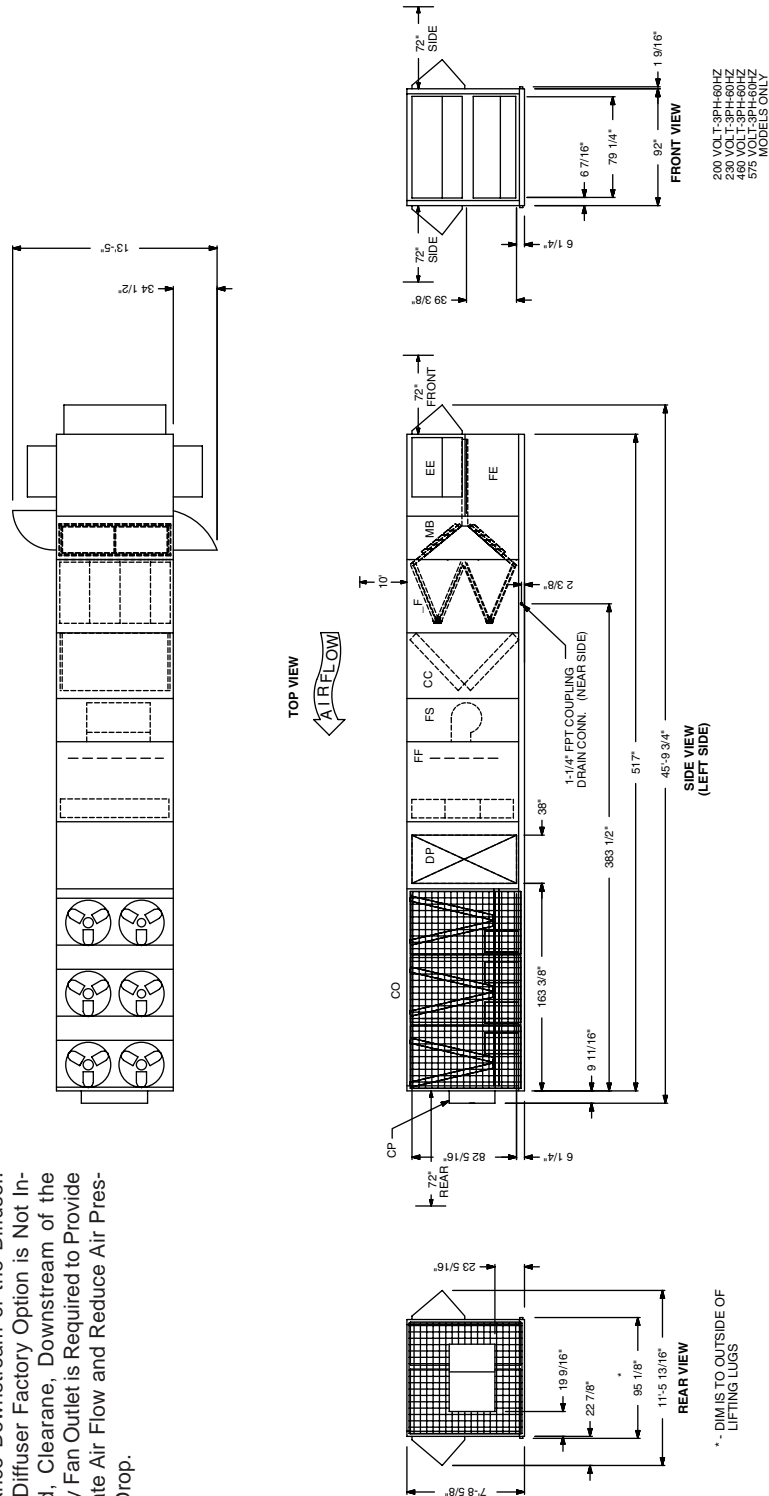

200 VOLT, 3PH, 60HZ
 230 VOLT, 3PH, 60HZ
 480 VOLT, 3PH, 60HZ
 575 VOLT, 3PH, 60HZ
 MODELS ONLY

FIG. 10 – GENERAL ARRANGEMENT DRAWING

LD08138

General Arrangement Drawing – 90-105 Ton Models

EXTENDED CABINET / BOTTOM SUPPLY / BOTTOM RETURN

SECTION DESCRIPTIONS:

- EE = Economizer
- FE = Fan Exhaust
- MB = Mixing Box
- _F = Filter Segments
- CC = Cooling Coils
- FS = Supply Fan
- FF = Final Filter
- DP = Discharge Plenum
- CO = Condenser Section
- CP = Control Panel

- NOTES:**
1. 10' Clearance Minimal Over The Top of the Condensing Unit.
 2. Only One Adjacent Wall Can Exceed Unit Height.
 3. 12' Clearance Required to Adjacent Units
 4. 8' Service Access Recommended on One Side.
 5. Economizer and Exhaust Hoods, Where Applicable, are Folded Inside Unit for Shipment.
 6. Clearance Downstream of the Diffuser. If the Diffuser Factory Option is Not Installed, Clearane, Downstream of the Supply Fan Outlet is Required to Provide Adequate Air Flow and Reduce Air Pressure Drop.

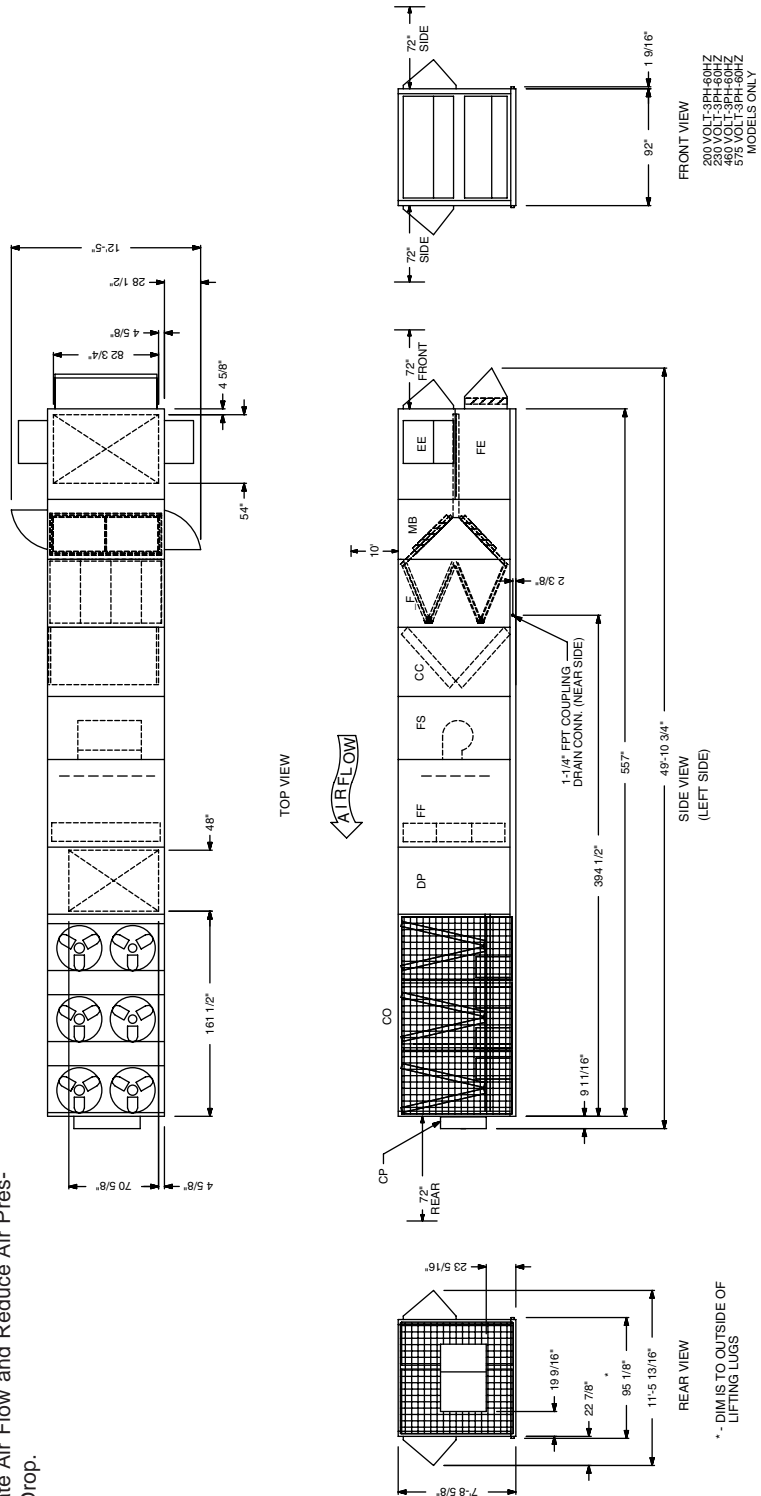

FIG. 10 – GENERAL ARRANGEMENT DRAWING

General Arrangement Drawing — 90-105 Ton Models

EXTENDED CABINET / LEFT SUPPLY / LEFT RETURN

SECTION DESCRIPTIONS:

- EE = Economizer
- FE = Fan Exhaust
- MB = Mixing Box
- _F = Filter Segments
- CC = Cooling Coils
- FS = Supply Fan
- FF = Final Filter
- DP = Discharge Plenum
- CO = Condenser Section
- CP = Control Panel

NOTES:

1. 10' Clearance Minimal Over The Top of the Condensing Unit.
2. Only One Adjacent Wall Can Exceed Unit Height.
3. 12' Clearance Required to Adjacent Units
4. 8' Service Access Recommended on One Side.
5. Economizer and Exhaust Hoods, Where Applicable, are Folded Inside Unit for Shipment.
6. Clearance Downstream of the Diffuser. If the Diffuser Factory Option is Not Installed, Clearance, Downstream of the Supply Fan Outlet is Required to Provide Adequate Air Flow and Reduce Air Pressure Drop.

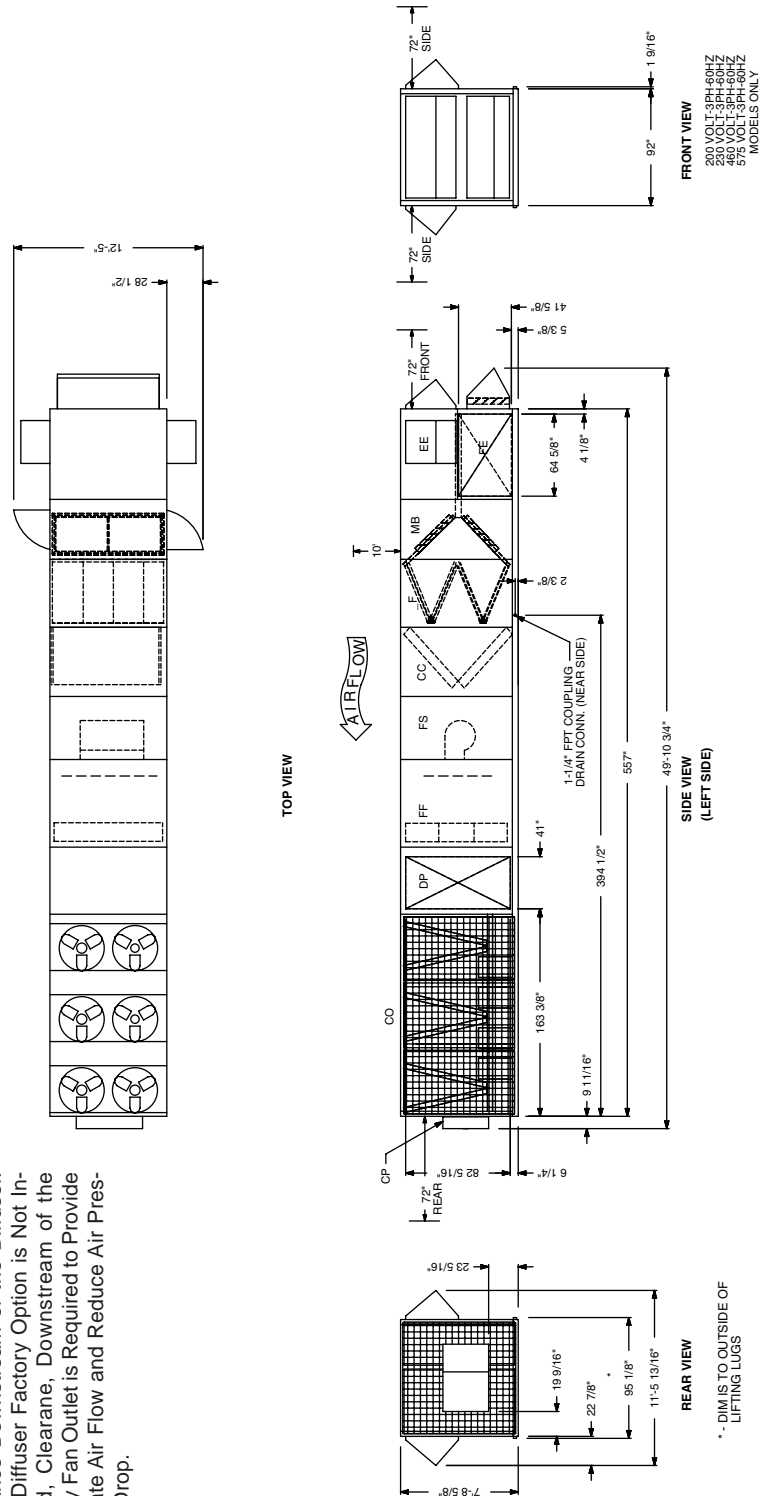

FIG. 10 – GENERAL ARRANGEMENT DRAWING

LD08137

EXTENDED CABINET / LEFT SUPPLY / BOTTOM RETURN

SECTION DESCRIPTIONS:

- EE = Economizer
- FE = Fan Exhaust
- MB = Mixing Box
- F = Filter Segments
- CC = Cooling Coils
- FS = Supply Fan
- FF = Final Filter
- DP = Discharge Plenum
- CO = Condenser Section
- CP = Control Panel

- NOTES:**
1. 10' Clearance Minimal Over The Top of the Condensing Unit.
 2. Only One Adjacent Wall Can Exceed Unit Height.
 3. 12' Clearance Required to Adjacent Units
 4. 8' Service Access Recommended on One Side.
 5. Economizer and Exhaust Hoods, Where Applicable, are Folded Inside Unit for Shipment.
 6. Clearance Downstream of the Diffuser. If the Diffuser Factory Option is Not Installed, Clearance, Downstream of the Supply Fan Outlet is Required to Provide Adequate Air Flow and Reduce Air Pressure Drop.

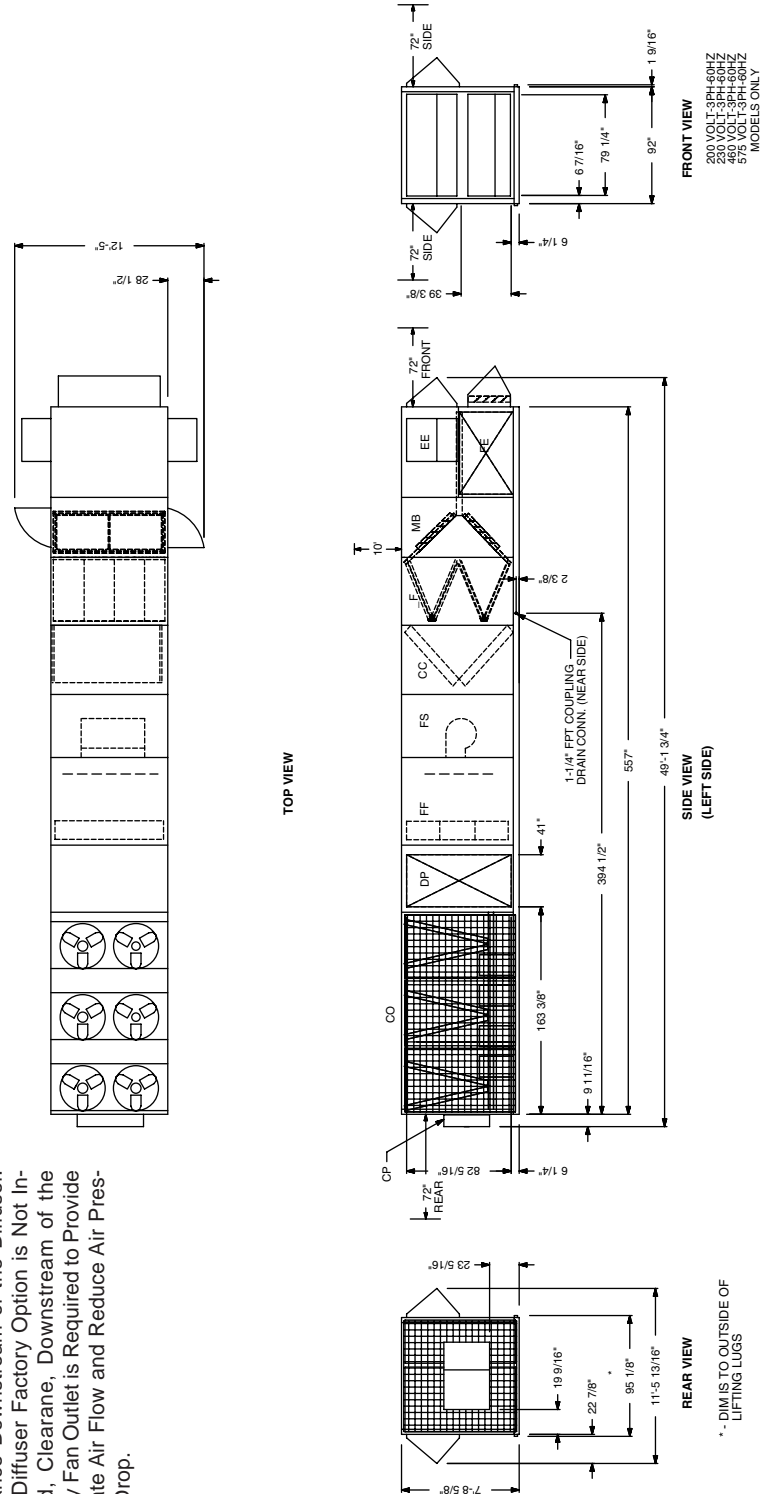
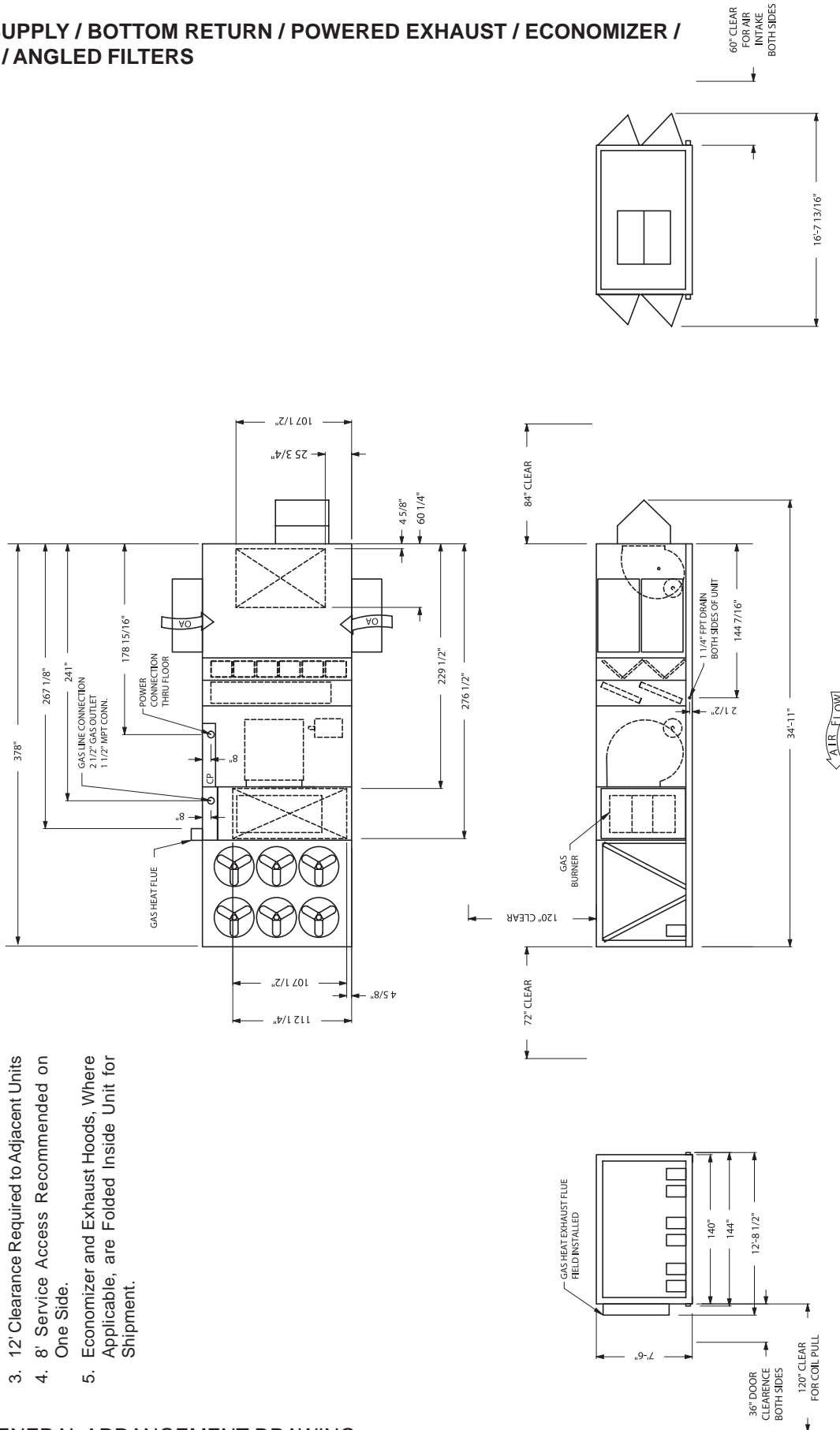

FIG. 10 – GENERAL ARRANGEMENT DRAWING

General Arrangement Drawing – 106-130 Ton Models

BOTTOM SUPPLY / BOTTOM RETURN / POWERED EXHAUST / ECONOMIZER / GAS HEAT / ANGLED FILTERS



NOTES:

1. 10' Clearance Minimal Over The Top of the Condensing Unit.
2. Only One Adjacent Wall Can Exceed Unit Height.
3. 12' Clearance Required to Adjacent Units
4. 8' Service Access Recommended on One Side.
5. Economizer and Exhaust Hoods, Where Applicable, are Folded Inside Unit for Shipment.

FIG. 10 – GENERAL ARRANGEMENT DRAWING

**LEFT SUPPLY / END RETURN / POWERED EXHAUST /
ECONOMIZER / GAS HEAT / ANGLED FILTERS**

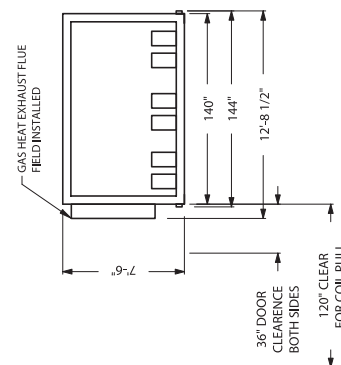
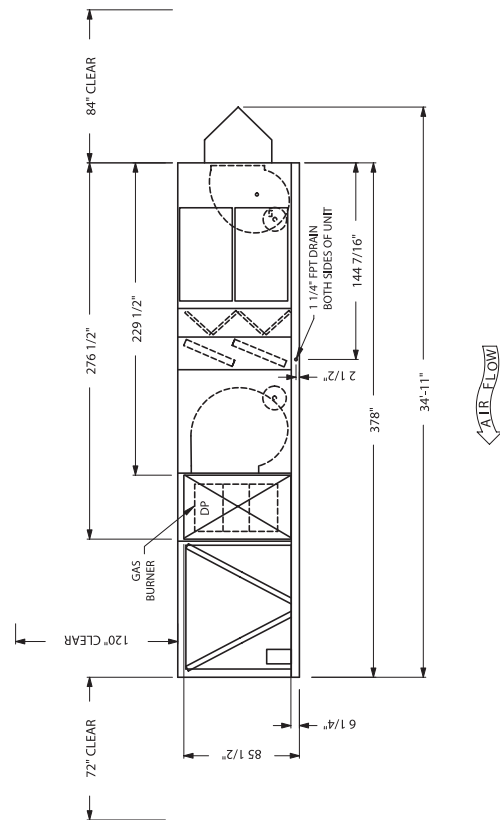
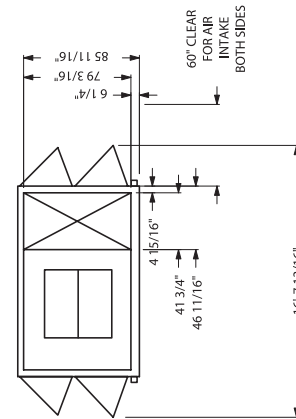
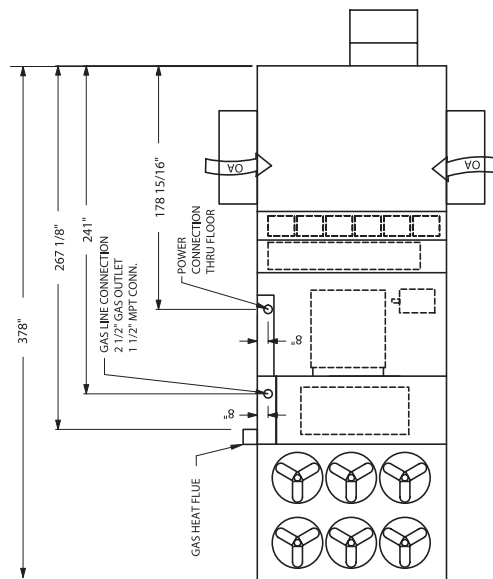

NOTES:

1. 10' Clearance Minimal Over The Top of the Condensing Unit.
2. Only One Adjacent Wall Can Exceed Unit Height.
3. 12' Clearance Required to Adjacent Units
4. 8' Service Access Recommended on One Side.
5. Economizer and Exhaust Hoods, Where Applicable, are Folded Inside Unit for Shipment.

FIG. 10 – GENERAL ARRANGEMENT DRAWING

General Arrangement Drawing – 106-130 Ton Models

**BOTTOM SUPPLY / BOTTOM RETURN / POWERED RETURN FAN /
ECONOMIZER / ELECTRIC HEAT / RIGID FILTERS**

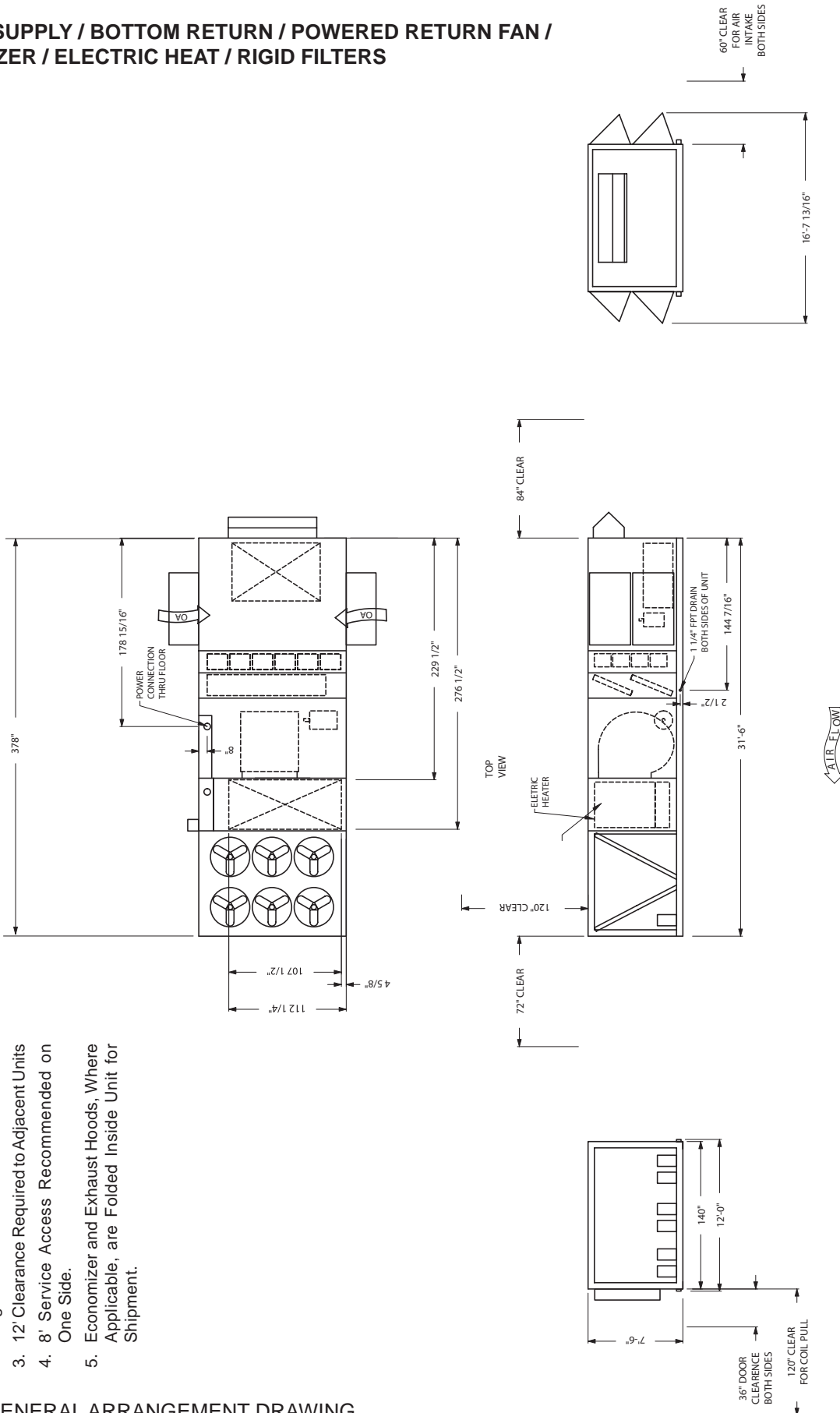

NOTES:

1. 10' Clearance Minimal Over The Top of the Condensing Unit.
2. Only One Adjacent Wall Can Exceed Unit Height.
3. 12' Clearance Required to Adjacent Units
4. 8' Service Access Recommended on One Side.
5. Economizer and Exhaust Hoods, Where Applicable, are Folded Inside Unit for Shipment.

FIG. 10 – GENERAL ARRANGEMENT DRAWING

LD08175

**BOTTOM SUPPLY / END RETURN / BAROMETRIC RELIEF /
ECONOMIZER / ELECTRIC HEAT / ANGLED FILTERS**

NOTES:

1. 10' Clearance Minimal Over The Top of the Condensing Unit.
2. Only One Adjacent Wall Can Exceed Unit Height.
3. 12' Clearance Required to Adjacent Units
4. 8' Service Access Recommended on One Side.
5. Economizer and Exhaust Hoods, Where Applicable, are Folded Inside Unit for Shipment.

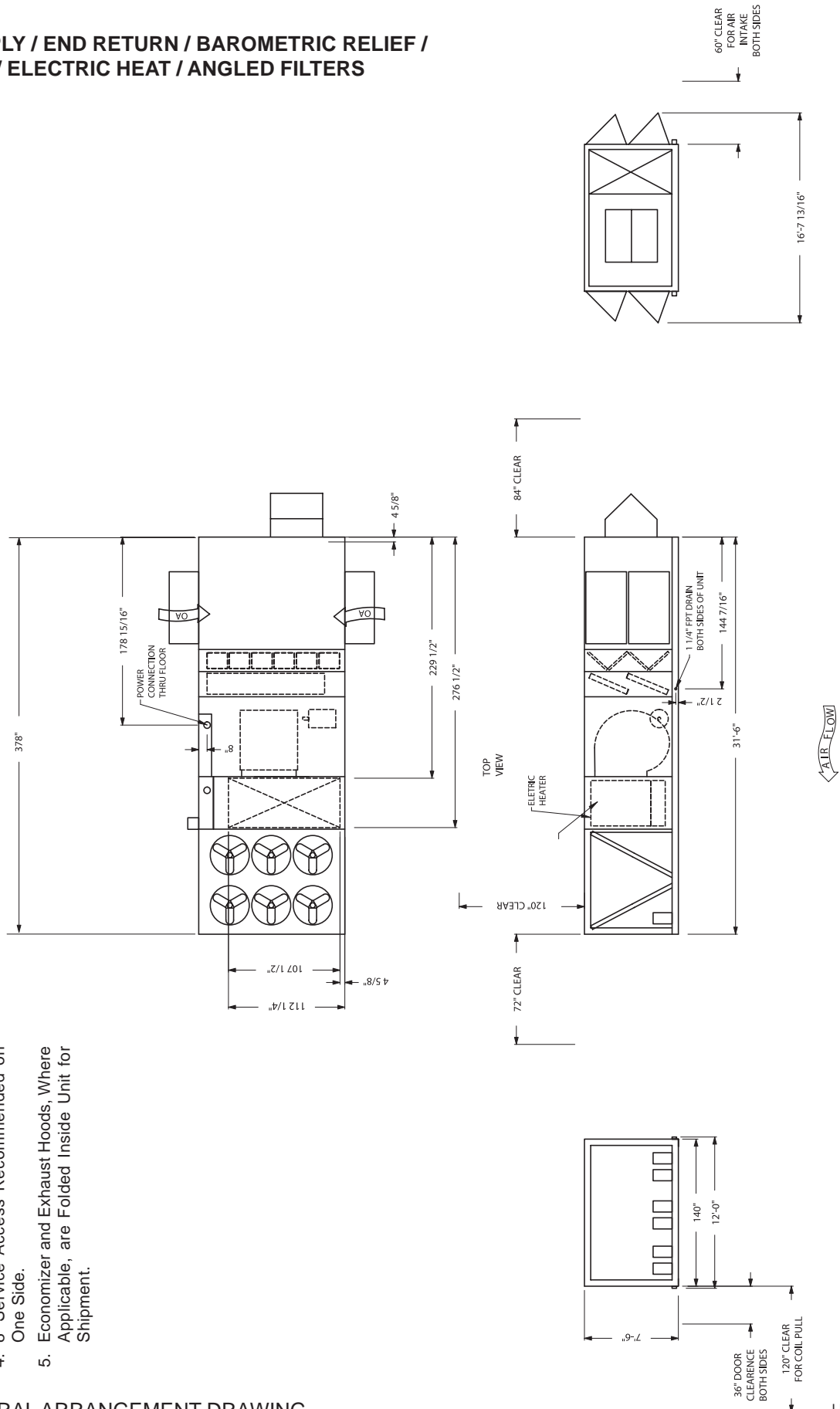
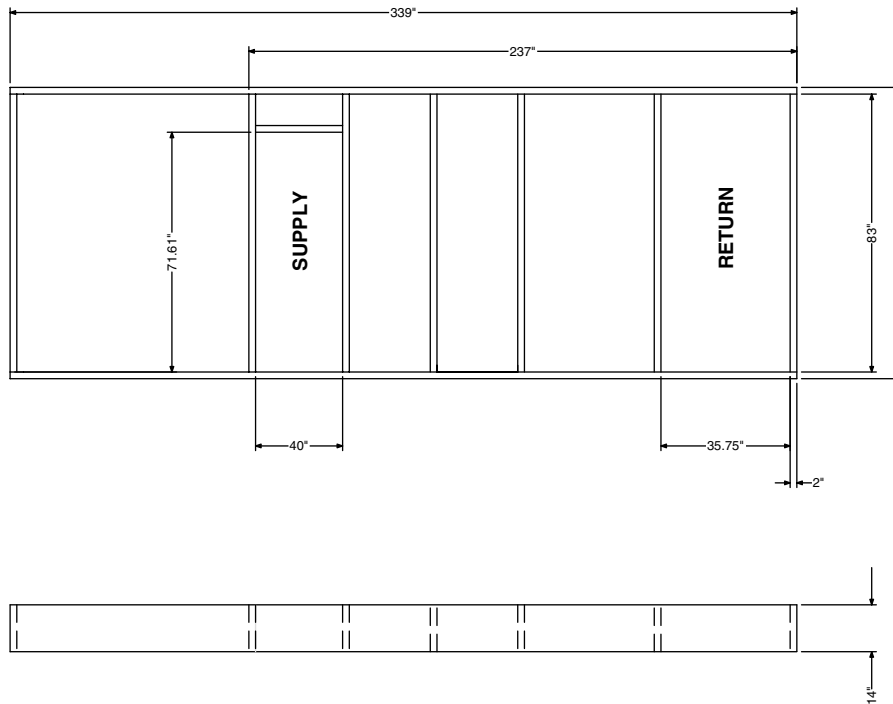

FIG. 10 – GENERAL ARRANGEMENT DRAWING

General Arrangement Drawing

CURB LAYOUT DRAWING / 50-65 TON MODEL



LD08142

CURB LAYOUT DRAWING / 70-85 TON MODEL

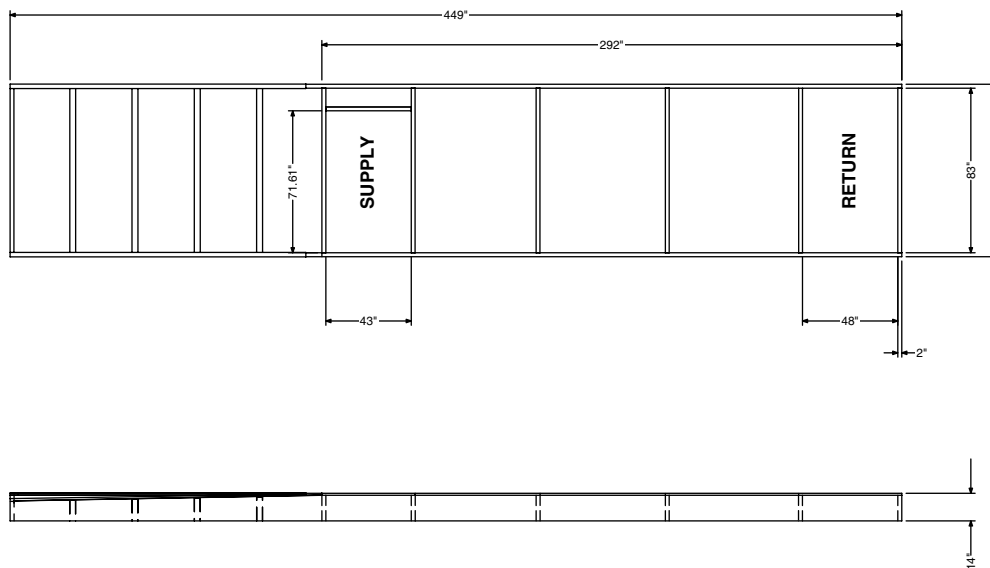

NOTES:

1. Unit must be installed square and level.
2. Curb configuration for "bottom" return and "bottom" supply.
3. These drawings are not intended as construction documents for the field fabricated roof curbs. YORK will not be responsible for the unit fit up, leak integrity, or sound level for installation using field fabricated roof curbs.
4. The YPAL unit does not have a base pan under the condensing section of the unit. Field fabricated roof curbs must have a cap on the top of the condensing section of the curb to prevent moisture from entering the space. The cap design must be sloped away from the supply duct opening to the end of the unit for the drainage of the moisture off of the top of the cap.

FIG. 10 – GENERAL ARRANGEMENT DRAWING

LD08143

CURB LAYOUT DRAWING / 90-95 TON MODEL

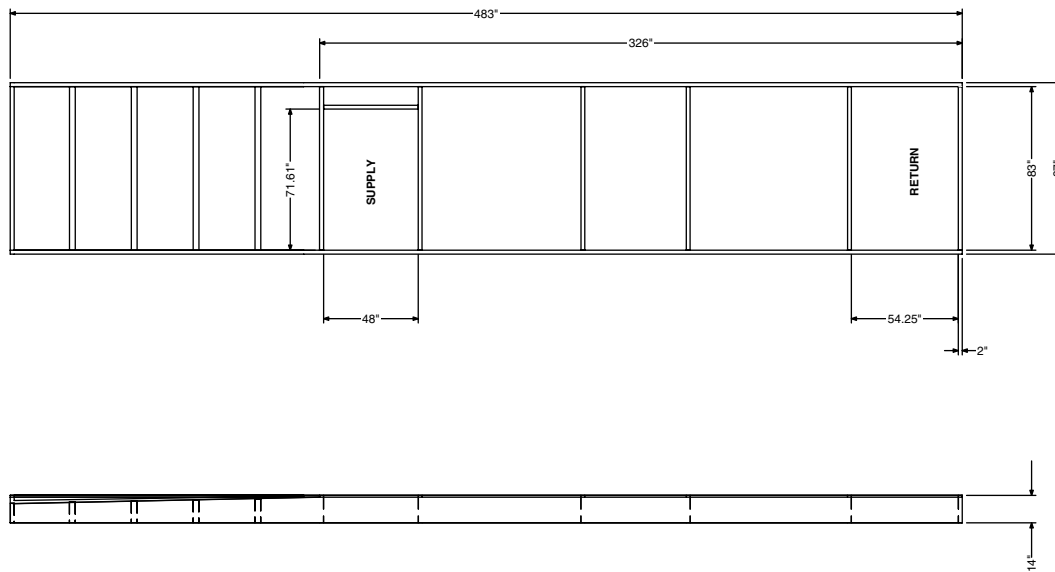

LD08144

EXTENDED CURB LAYOUT DRAWING / 50-65 TON MODEL

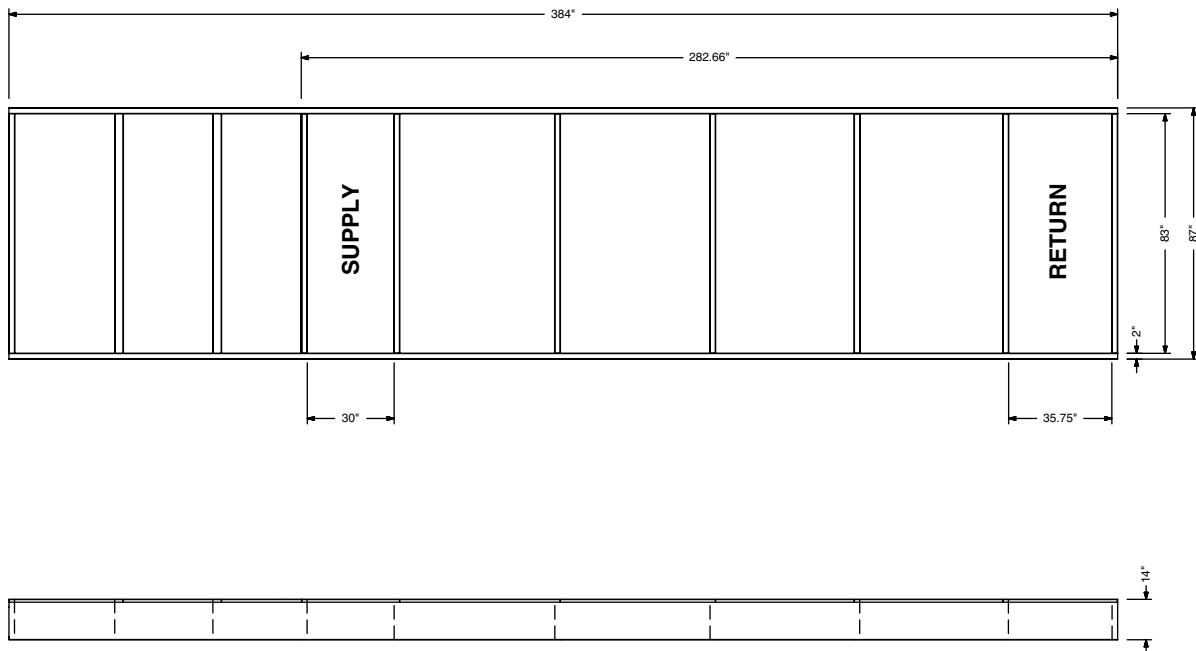

NOTES:

1. Unit must be installed square and level.
2. Curb configuration for "bottom" return and "bottom" supply.
3. These drawings are not intended as construction documents for the field fabricated roof curbs. YORK will not be responsible for the unit fit up, leak integrity, or sound level for installation using field fabricated roof curbs.
4. The YPAL unit does not have a base pan under the condensing section of the unit. Field fabricated roof curbs must have a cap on the top of the condensing section of the curb to prevent moisture from entering the space. The cap design must be sloped away from the supply duct opening to the end of the unit for the drainage of the moisture off of the top of the cap.

FIG. 10 – GENERAL ARRANGEMENT DRAWING

LD08145

General Arrangement Drawing

EXTENDED CURB LAYOUT DRAWING / 90-95 TON MODEL

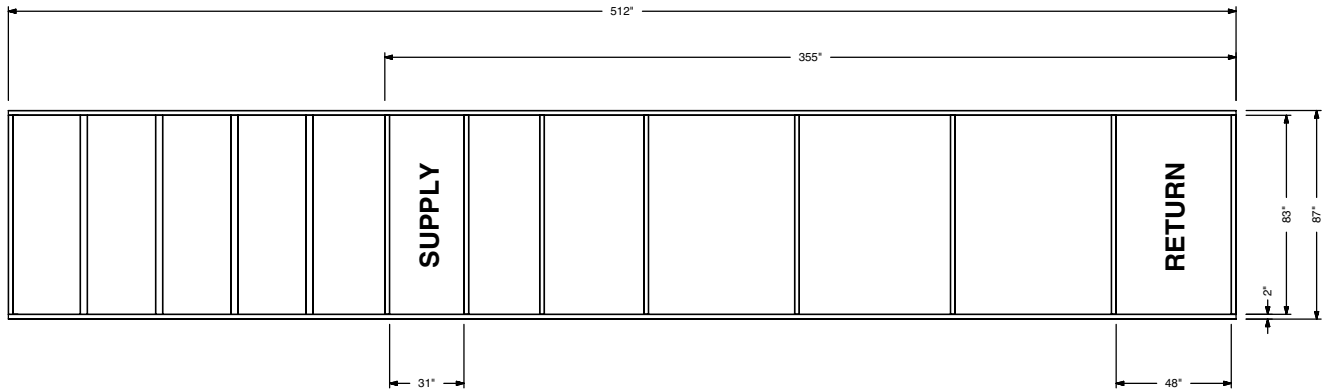

LD08146

EXTENDED CURB LAYOUT DRAWING / 70-85 TON MODEL

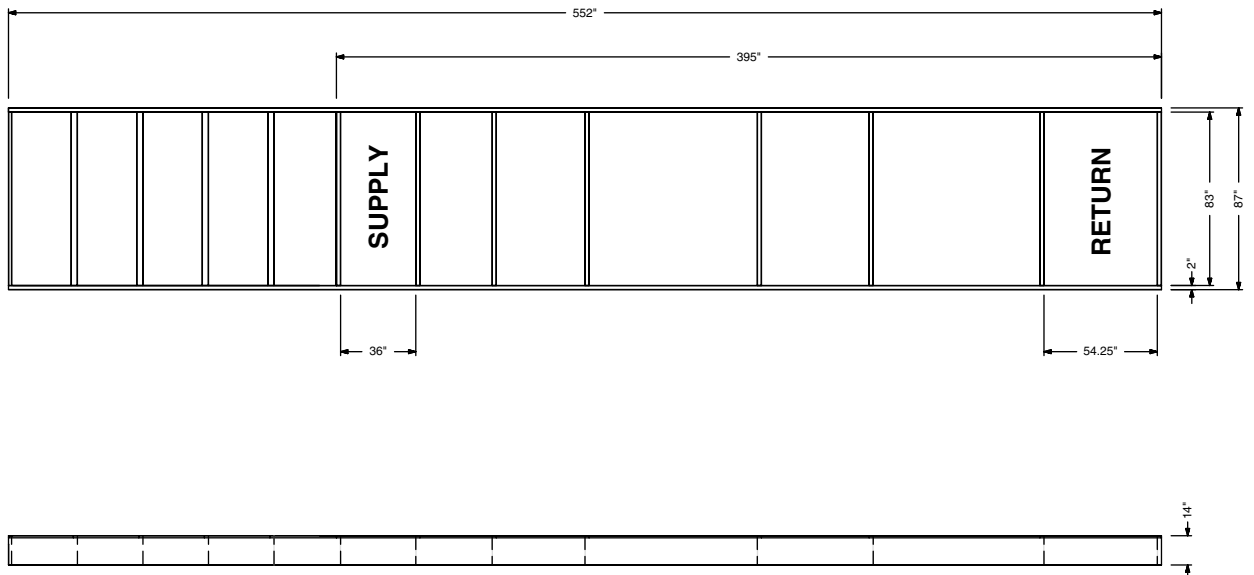

NOTES:

1. Unit must be installed square and level.
2. Curb configuration for "bottom" return and "bottom" supply.
3. These drawings are not intended as construction documents for the field fabricated roof curbs. YORK will not be responsible for the unit fit up, leak integrity, or sound level for installation using field fabricated roof curbs.
4. The YPAL unit does not have a base pan under the condensing section of the unit. Field fabricated roof curbs must have a cap on the top of the condensing section of the curb to prevent moisture from entering the space. The cap design must be sloped away from the supply duct opening to the end of the unit for the drainage of the moisture off of the top of the cap.

FIG. 10 – GENERAL ARRANGEMENT DRAWING

LD08147

CURB LAYOUT DRAWING / 130 TON MODEL

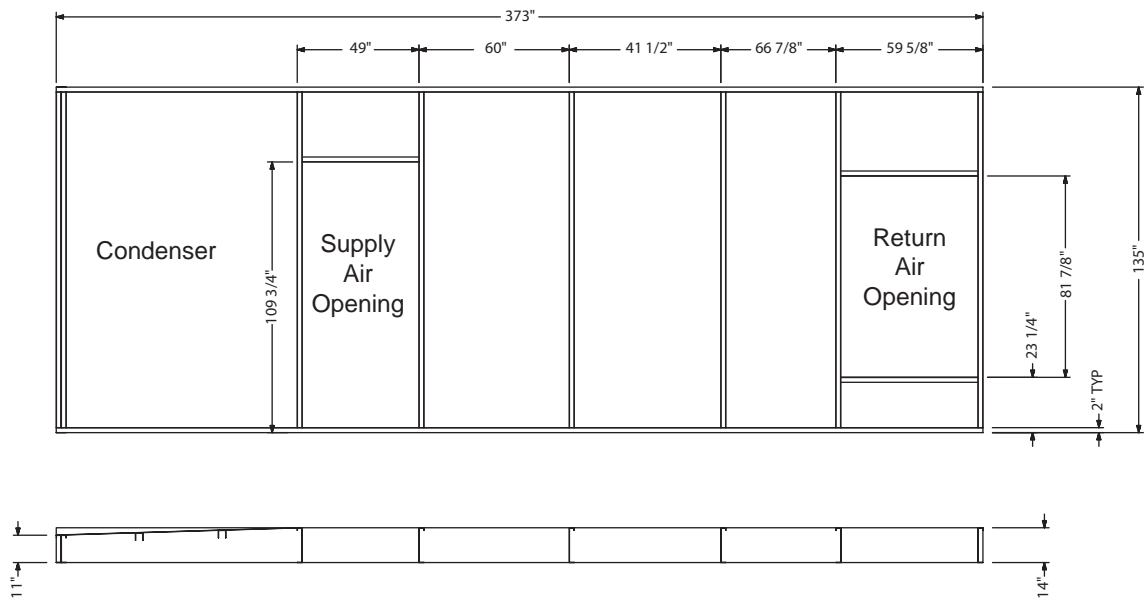

LD08177

NOTES:

1. Unit must be installed square and level.
2. Curb configuration for "bottom" return and "bottom" supply.
3. These drawings are not intended as construction documents for the field fabricated roof curbs. YORK will not be responsible for the unit fit up, leak integrity, or sound level for installation using field fabricated roof curbs.
4. The YPAL unit does not have a base pan under the condensing section of the unit. Field fabricated roof curbs must have a cap on the top of the condensing section of the curb to prevent moisture from entering the space. The cap design must be sloped away from the supply duct opening to the end of the unit for the drainage of the moisture off of the top of the cap.

FIG. 10 – GENERAL ARRANGEMENT DRAWING

Hot Water/Steam Coil Connection Locations

HOT WATER COIL WITH CONTROL PACKAGE

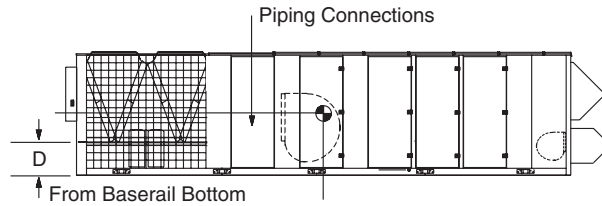
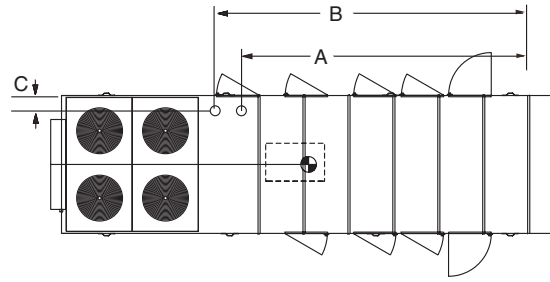

LD08118

HOT WATER & STEAM WITHOUT CONTROL PACKAGE

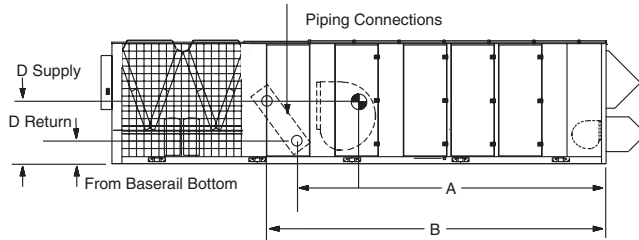
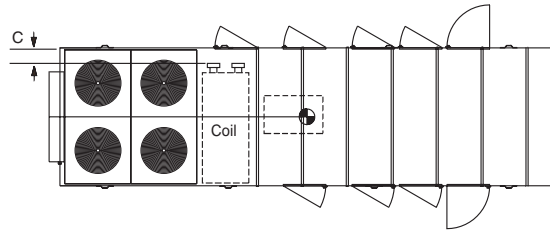

LD08119

TABLE 50 – FITTING LOCATION DIMENSIONS

Unit Size	A	B	C	D _{supply}	D _{return}	Connection Sizes inches)	
	Note 1	Note 2	Note 3	Note 4	Note 4	Supply	Return
Hot water with Control Package							
50-65	219.00	227.70	5.25	11.00	11.00	For control package	
70-85	271.30	280.00	5.25	12.20	12.20	connection sizes	
90-95	299.80	308.50	5.25	11.90	11.90	see table on right.	
Hot Water without Control Package							
50-65	202.20	230.50	6.25	42.10	14.80	2" FPS	2" FPS
70-85	254.60	285.60	6.25	45.60	16.00	2" FPS	2" FPS
90-95	283.10	319.80	6.25	50.10	15.50	2" FPS	2" FPS
Steam without Control Package							
50-65	202.20	217.00	5.75	25.80	14.80	2" MPT	1.5" MPT
70-85	254.60	270.50	5.75	31.90	16.00	2" MPT	1.5" MPT
90-95	283.10	301.50	5.75	32.60	15.60	2" MPT	1.5" MPT

NOTES:

- A. Location of return line connection, horizontal from economizer corner post, in direction of airflow
- B. Location of supply line connection, horizontal from economizer cornerpost, in direction of airflow
- C. Location of both supply and return lines, horizontal from outside casing of unit, across direction of airflow
- D. Location of supply and return lines, vertical from bottom edge of base rail

MPT = Male Pipe Thread FPS = Female Pipe Sweat FPT = Female Pipe Thread

Hot Water Coil Connections w/ controls are valve connections facing bottom of the unit, at locations indicated.

Steam and Hot Water connections w/o controls are fittings connections facing side of the unit, at locations indicated.

Power/Control Entry Drawing

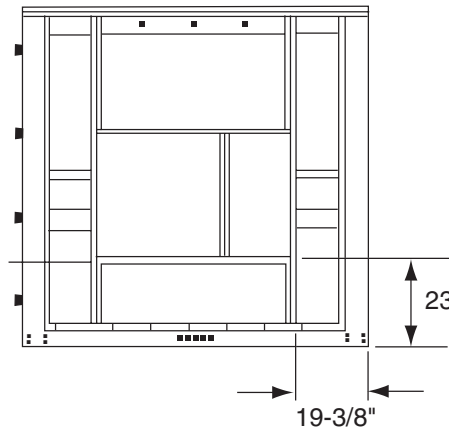

POWER SUPPLY KNOCKOUTS

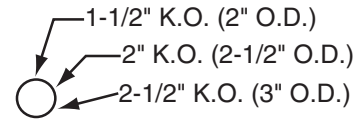

CONDENSER END VIEW

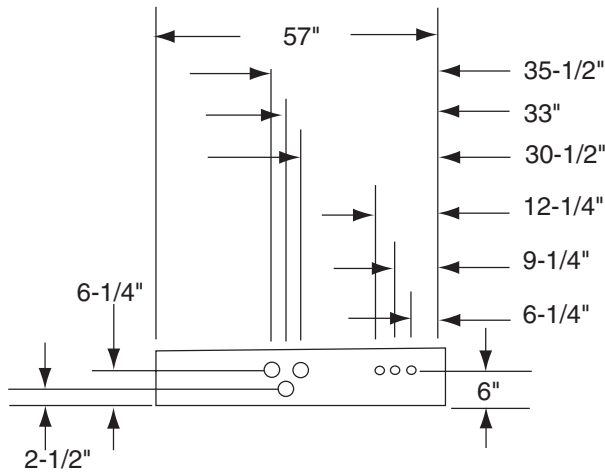

PANEL A
3/4" K.O. (CONTROL WIRING)

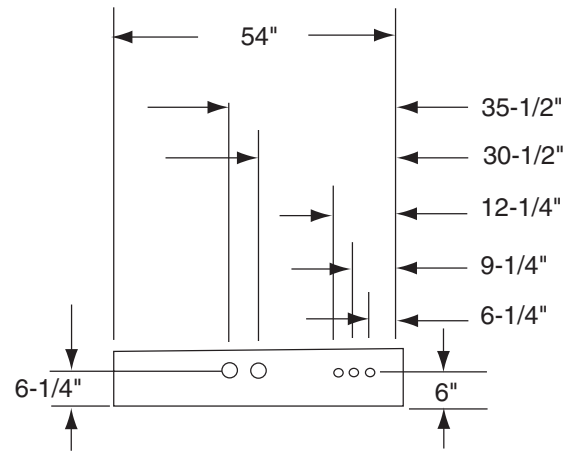

PANEL B
3/4" K.O. (CONTROL WIRING)

BOTTOM VIEW

LD07315

TABLE 51 – POWER/CONTROL ENTRY DIMENSIONS

Model	208V	230V	460V	575V
50	A	A	B	B
55	A	A	B	B
60	A	A	B	B
65	A	A	B	B
70	A	A	B	B
75	A	A	B	B
80	A	A	B	B
85	A	A	B	B
90	A	A	A	A
95	A	A	A	A
105	A	A	A	A

FIG. 11 – POWER/CONTROL ENTRY DRAWING – 50 - 95 TON MODELS

This page intentionally left blank

Guide Specifications

GENERAL

Scope

The requirements of the General Conditions, Supplementary Conditions, Division 1 and drawings apply to all work herein.

Provide Microprocessor-controlled, air-cooled, double-wall construction outdoor packaged rooftop air conditioning product of the scheduled capacities and performance as shown and indicated on the Drawings, including but not limited to:

1. Single-piece rooftop package
2. Charge of refrigerant and oil
3. Electrical power and control connections
4. Supply and return duct connections
5. Factory start-up

Quality Assurance

All units are tested, rated or certified, as applicable, in accordance with the following standards, guidelines and codes:

1. All units shall meet the latest ASHRAE 90.1 minimum energy-efficiency requirements (EER)
2. All units shall meet the latest ASHRAE 62 requirements for ventilation and indoor air quality.
3. All units shall be rated in accordance with the ARI Standard 340/360
4. All units shall be tested to ANSI/UL 1995 and CAN/CSA C22.2 No. 236 standards
5. Gas heating units shall be designed in conform to ANSI Z21.47-1998/CSA 2.3-M98 standards and be carry the UL listing
6. Units shall be ETL and ETL Canada listed

Manufacturers: The design shown on the drawing is based upon products of the manufacturer scheduled. Alternate equipment manufacturers shall be acceptable if equipment meets the scheduled performance and complies with these specifications. If equipment manufactured by manufacturer other than that scheduled is utilized, then the Mechanical Contractor shall be responsible for coordinating with the General Contractor and all affected Subcontractors to insure proper provisions for installation of the furnished unit. This coordination shall include, but not be limited to, the following:

1. Structural supports for units.
2. Roof curb transition.
3. Piping size and connection/header locations.

4. Electrical power requirements and wire/conduit and overcurrent protection sizes.
5. All costs incurred to modify the building provisions to accept the furnished units.

Warranty: Manufacturer shall warrant all equipment and material of its manufacture against defects in workmanship and material for a period of eighteen (18) months from date of shipment.

1. The warranty shall include parts only during this period.
2. The warranty shall not include parts associated with routine maintenance, such as belts, air filters, etc.

Delivery and Handling

Unit shall be delivered to the job site fully assembled, wired, and charged with refrigerant and oil by the manufacturer.

Unit shall be stored and handled per Manufacturer's instructions.

All handling and storage procedures shall be per manufacturer's recommendations.

Submittals

Shop Drawings: Shop drawing submittals shall include, but not limited to, the following: drawings indicating components, dimensions, weights, required clearances, and location, type and size of field connections, and power and control wiring connections.

Product Data: Product data shall include dimensions, weights, capacities, ratings, fan performance, motor electrical characteristics, and gauges and finishes of materials.

Documentation:

1. Fan curves with specified operating point clearly plotted shall be provided.
2. Product data of filter media, filter performance data, filter assembly, and filter frames shall be provided.
3. Electrical requirements for power supply wiring; including wiring diagrams for interlock and control wiring shall be supplied. Factory and field-installed wiring shall be clearly indicated.
4. Operation and maintenance documentation shall be supplied in accordance with Section 01830 – Operation and Maintenance, including but not limited to instructions for lubrication, filter replacement, compressor, motor and drive replacement, coil cleaning, filter maintenance, spare parts lists, and wiring diagrams.

Guide Specifications (continued)

Warranties

Equipment shall include the manufacturer's warranty not less than eighteen months from the date of shipment.

Extended parts warranty [optional] shall be included for an additional one [five] years

Extended parts and labor warranty [optional] shall be included for an additional one [five] years

EQUIPMENT

Product Specification

Summary: Completely factory assembled unitized construction packaged rooftop air conditioning unit including a factory-mounted and wired unit controller and sensors, single-point power connection 460V [208V/230V/575V] three-phase, 60Hz power supply, outdoor air handling section with return and supply openings, discharge plenum, direct-expansion refrigerant condensing section.

Factory Test: The refrigerant circuit shall be pressure-tested, evacuated and fully charged with refrigerant and oil. The completed refrigerant circuit shall undergo a factory helium leak test and undergo an automated operational run test and quality inspection prior to shipment. The unit controller shall be configured and run tested at the factory to minimize field setup time. If the unit is not configured and tested, then the manufacturer shall provide field start up and testing to ensure that the controller is functioning properly.

Unit Construction:

Base Rail: The unit shall include an integral design base rail with lifting points clearly marked and visible on the base rail and a 1-1/4" FPT connection for condensate drainage. The unit base shall be designed with a recessed curb mounting location. The recessed curb-mounting surface shall provide a continuous surface for field application of curb gasketing to create a weather tight seal between the curb and unit.

Casing: Casing shall be complete post and panel construction with exterior skin. All panels, doors, walls, uprights, floor panels and roofing shall be one-inch thick; 1-1/2 pound density insulation. Units are specifically designed for outdoor installation.

Roof: The unit roof shall be bowed with the peak in the middle of the unit and sloped to both sides of the unit for drainage. A drip lip shall run the length of the unit to prevent water drainage down the side of the unit. Roof

and sidewall seams shall be continuously caulked and covered with formed galvanized seam caps. All panel fasteners shall be secured through standing seams to prevent fastener penetrations that are exposed to the air stream.

Paint: Exterior painted surfaces are designed to withstand a minimum of 500 salt spray hours when tested in accordance with ASTM B-117.

Markings and Diagrams: All necessary tags and decals to aid in the service and/or indicating caution areas shall be provided. Electrical wiring diagrams shall be attached to the control panel access door.

Documentation: Installation and maintenance manuals shall be supplied with each unit.

Access Doors: Double wall access doors shall be provided in the fan, coil, filter and inlet sections of the unit on both sides of the unit. Doors shall be double-wall construction with a solid liner and a minimum thickness of 1-inch. Doors shall be attached to the unit with piano-type stainless steel hinges. Latches shall be positive-action, creating an airtight seal between the door and unit. Panels and doors shall be completely gasketed with a closed-cell, neoprene gasket. Door tiebacks shall be provided for all doors to secure doors while servicing.

Economizer Section:

[SELECT NONE, OR ONE OF THE FOLLOWING]

1. No Outside Air: the unit has no provisions for outside ventilation air.
1. Manual Outside Air Damper: A manually adjustable outside air damper capable of admitting 0-25% outside air shall be provided.
1. Two-Position Outside Air Damper: A two position damper outside air damper capable of admitting 0-25% outside air shall be provided. The minimum position shall be manually adjustable from 0-25%. Control shall be based on the occupied mode of the unit. For occupied mode, the damper shall be open to the minimum position and for unoccupied, it shall be closed.
1. Modulating Economizer: The economizer segment shall be designed to use outside air for cooling and ventilation and provide a means of exhausting air from the air-handling unit. The segment shall consist of parallel acting low-leak dampers. The return air, outside air and exhaust air dampers shall be sized for 100% of nominal unit airflow. The exhaust air damper assembly shall have a factory-assembled rain hood. The rain hood shall have a drip-lip the full width of the hood to channel moisture away from the air being drawn into the unit.

[SELECT ONE OF THE FOLLOWING TYPES OF BUILDING PRESSURE CONTROL]

2. No Building Exhaust/Relief: The unit has no provisions to exhaust building return air.
2. Barometric Relief Damper: Building air exhaust shall be accomplished through barometric relief dampers installed in the return air plenum. The dampers open relative to the building pressure. The opening pressure shall be adjustable.
2. On/Off Fan Powered Exhaust: A DWDI Class II forward-curved centrifugal exhaust fan shall be provided to exhaust building return air to relieve building static pressure. The fans shall be constant volume and operate based on either a building static pressure, or outside air damper position.
2. Powered Exhaust with Modulating Discharge Damper: A DWDI Class II forward-curved centrifugal exhaust fan shall be provided to exhaust building return air to relieve building static pressure. The fans shall operate at a constant volume and operate based on building static pressure. Exhaust airflow shall be modulated via a parallel-acting control damper. The exhaust air dampers shall be sized for 100% of the exhaust airflow.
2. Powered Exhaust with Variable-Frequency-Drive: A twin DWDI Class II forward-curved centrifugal exhaust fan shall be provided to exhaust building return air to relieve building static pressure. Exhaust airflow shall be modulated via a factory-installed and commissioned variable-frequency-drive with the same nameplate horsepower as the supply fan motor.
2. Power Return Fan – A SWSI plenum fan shall be provided to draw return air from the building to the rooftop unit. An access door shall be provided on at least one side of the unit for fan/motor access. The return fan shall operate to maintain a constant pressure within the return plenum.
2. Power Return Fan – A SWSI plenum fan shall be provided to draw return air from the building to the rooftop unit. An access door shall be provided on at least one side of the unit for fan/motor access. The return fan shall operate to maintain a constant pressure within the return plenum. A discharge damper shall be provided to modulate building exhaust. The damper shall be controlled via building pressure. The return damper shall be linked with the outside air damper to modulate volumes of return and outside airflows.

[FOR POWERED EXHAUST OR RETURN FAN OPTIONS ABOVE, USE THE FOLLOWING]

3. Fan Motor: Fan motors shall be NEMA design ball-bearing types with electrical characteristics and

horsepower as specified. Motors shall be 1750 RPM, open drip-proof type. The motor shall be located within the unit on an adjustable base.

Mountings: Fan and fan motor shall be internally mounted and isolated on a full width isolator support channel using 1-inch springs **[2-inch springs and seismic restraints]**. The fan discharge shall be connected to the fan cabinet using a flexible connection to insure vibration-free operation.

Bearings and Drives: Fan bearings shall be self-aligning, pillow block or flanged type regreaseable ball bearings and shall be designed for an average life (L50) of at least 200,000 hours. All bearings shall be factory lubricated and equipped with standard hydraulic grease fittings and lube lines extended to the motor side of the fan. Fan drives shall be selected for a 1.5 service factor and anti-static belts shall be furnished. All drives shall be fixed pitch. Fan shafts shall be selected to operate well below the first critical speed and each shaft shall be factory coated after assembly with an anti-corrosion coating.

Filter Section:**[SELECT A FILTER RACK, FILTER MEDIA, AND SWITCH IF DESIRED]**

1. Angled Filter Rack: two-inch throwaway filters shall be provided in an angled filter rack.
1. Angled Filter Rack: two-inch carbon media filters shall be provided in an angled filter rack.
1. Angled Filter Rack: two-inch cleanable filters shall be provided in an angled filter rack.
1. Angled Filter Rack: two-inch high-efficiency (30%) pleated filters shall be provided in an angled filter rack.
1. Flat Filter Rack: 60-65% Efficient Rigid Filters with a two-inch high-efficiency pleated pre-filters shall be provided in a flat filter rack.
1. Flat Filter Rack: 90-95% Efficient Rigid Filters with a two-inch high-efficiency pleated pre-filters shall be provided in a flat filter rack.
2. Dirty Filter Alarm: A dirty filter switch shall be provided and wired to the rooftop unit control panel. Upon closure of the switch, the controller shall display a dirty filter fault. The setting of the switch can be changed manually to close at a specified pressure drop across the filters.

Evaporator Section

1. Cooling Coil: Evaporator coils shall be direct expansion type with intertwined circuiting to assure complete coil face activity during part load operation. Coil tubes shall be 1/2" OD copper, with internally enhanced tubes. Fins shall be enhanced me-

Guide Specifications (continued)

chanically expanded to bond with the copper tubes. Coil casing shall be fabricated from heavy gauge galvanized steel. All coils shall be pressure tested at a minimum of 450 PSIG.

2. IAQ Drain Pan: The main coil drain pan shall be double-sloped with a condensate connection through the base rail of the unit. Clearance between the evaporator coil and the drain pan shall allow for easy access to the drain pan for cleaning, and shall be visible for inspection without the removal of components.
3. Intermediate Drain Pan: Coils with finned height greater than 48" shall have an intermediate drain pan extending the entire finned length of the coil. The intermediate pans shall have drop tubes to guide condensate to the main drain pan.

Supply Fan Section

1. Fan: The fan section shall be equipped with a single double width, double inlet (DWDI) forward-curved **[airfoil optional]** centrifugal type wheels for horizontal discharge. An access door shall be provided on both sides of the unit for fan/motor access.
2. Fan Motor: Fan motors shall be NEMA design ball-bearing types with electrical characteristics and horsepower as specified. Motors shall be 1750 RPM, open drip-proof type **[TEAO optional]**. The motor shall be located within the unit on an adjustable base.

Mountings: Fan and fan motor shall be internally mounted and isolated on a full width isolator support channel using 1-inch **[2-inch optional]** springs **[with optional seismic restraints]**. The fan discharge shall be connected to the fan cabinet using a flexible connection to insure vibration-free operation.

Bearings and Drives: Fan bearings shall be self-aligning, pillow block or flanged type regreaseable ball bearings and shall be designed for an average life (L50) of at least 200,000 hours. All bearings shall be factory lubricated and equipped with standard hydraulic grease fittings and lube lines extended to the motor side of the fan. Fan drives shall be selected for a 1.5 service factor and anti-static belts shall be furnished. All drives shall be fixed pitch. Fan shafts shall be selected to operate well below the first critical speed and each shaft shall be factory coated after assembly with an anti-corrosion coating.

3. VAV Fan Control: VAV supply fan control shall be accomplished by using a variable-frequency-drive matched to the supply fan motor HP. The VFD shall include an integral DC line reactor to reduce harmonic distortion in the incoming and outgoing power

feeds. If a DC line reactor is not provided, an AC line reactor must be provided. Inlet guide vanes shall not be acceptable. VFD control keypads shall be located in the control cabinet for accessibility and servicing while the unit is operating.

4. Optional VFD manual bypass: a three contactor manual bypass shall be provided to permit replacement of the VFD in the event of a power failure.

Discharge Plenum

[SELECT ONE OF THE FOLLOWING HEAT/NO HEAT CONFIGURATIONS]

1. Cooling Only: The discharge air temperature sensor shall be located in the discharge plenum and be located such that it accurately measures the supply air temperature. Walls shall be lined with a solid liner to prevent erosion of the insulation and separate insulation from the air stream.
1. Staged Gas Heat: The heating section shall include an induced draft furnace in two stages [four stages or six stages] of heating capacity.

Heat Exchanger: The heat exchanger shall be constructed of tubular aluminized steel [stainless steel], with stainless steel flue baffles and flue assembly.

Burner and Ignition Control: The burner shall include a direct-driven induced-draft combustion fan with energy efficient intermittent pilot spark ignition, redundant main gas valves with pressure regulator.

Combustion Air Fan: The inducer fan(s) shall maintain a positive flow of air through each tube, to expel the flue gas and to maintain a negative pressure within the heat exchanger relative to the conditioned space.

Safety Devices: A high limit controller with automatic reset to prevent the heat exchanger from operating at an excessive temperature shall be included. A centrifugal switch on the induced draft fan motor shaft shall prevent ignition until sufficient airflow is established through the heat exchanger. A rollout switch shall provide secondary airflow safety protection. The rollout switch shall discontinue furnace operation if the flue becomes restricted.

Flue: The furnace flue shall be shipped loose to protect it from damage during transit. The flue shall be field-mounted by the installing contractor. The flue outlet shall be located above the unit to help prevent recycling of combustion gases back through the heat exchanger. Agency Certification: Gas heating sections are both UL and CGA approved to both US and Canadian safety standards.

1. Modulating Gas Heat: The heating section shall include an induced draft furnace in 8:1 modulation [16:1, 24:1] of heating capacity.

Heat Exchanger(s): The heat exchanger(s) shall be constructed of tubular aluminized steel [stainless steel], with stainless steel flue baffles and flue assembly.

Burner(s) and Ignition Control: The burner(s) shall include a direct-driven induced-draft combustion fan with energy efficient intermittent pilot spark ignition, redundant main gas valves with pressure regulator.

Combustion Air Fan(s): The inducer fan(s) shall maintain a positive flow of air through each tube, to expel the flue gas and to maintain a negative pressure within the heat exchanger relative to the conditioned space.

Safety Devices: A high limit controller with automatic reset to prevent the heat exchanger from operating at an excessive temperature shall be included. A centrifugal switch on the induced draft fan motor shaft shall prevent ignition until sufficient airflow is established through the heat exchanger. A rollout switch shall provide secondary airflow safety protection. The rollout switch shall discontinue furnace operation if the flue becomes restricted.

Flue: The furnace flue shall be shipped loose to protect it from damage during transit. The flue shall be field-mounted by the installing contractor. The flue outlet shall be located above the unit to help prevent recycling of combustion gases back through the heat exchanger.

Agency Certification: Gas heating sections are both UL and CGA approved to both US and Canadian safety standards.

1. Electric Heat

An electric slip-in heater is installed within the rooftop unit discharge plenum to provide the heating requirements per the schedule shown on the plans. The electric heater is wired in such a manner as to provide a minimum of two steps of capacity.

Heat Exchanger: The furnace is an industrial grade design using an open coil made of the highest-grade resistance wire containing 80% nickel and 20% chromium. The resistance coils are adequately supported in the air stream using ceramic bushings in the supporting framework. Terminals of the coil are stainless steel with high temperature ceramic bushings.

Safety Devices: The primary high temperature protection is an automatic reset type thermal cut out. Secondary protection is an automatic reset type thermal cut out. Secondary protection is a replaceable thermal link.

Agency Certification: The operation of the electric heater is an integral part of the roof top control sys-

tem. Power connection to the heater is through the power panel for the unit. Electric heat is ETL certified to both US and Canadian safety standards.

1. Hot Water Heating Coil

A hot water coil shall be installed in the rooftop unit discharge plenum.

Construction: The hot water coil shall have eight [10, 12, 14] fins per inch, 2 tubes per circuit, and an 2" inlet and outlet connection. Primary surface shall be 1/2" OD copper tube, staggered in direction of airflow. Connections have 1/4" FPT drain plug on each connection. A structural galvanized steel casing shall protect the coil. An intermediate coil support shall be provided. The coil shall be circuited to provide free draining and venting, through one vent and drain.

Testing: Completed coil, including headers, connections and return bends shall be tested with 325 pounds compressed air under water. Coils shall be designed for operation at 250 psig design working pressure.

1. Steam Heating Coil

A steam heating coil shall be installed in the rooftop unit discharge plenum.

Construction: The steam coil shall be constructed in the non-freeze style. The steam coil shall have six fins per inch, an 2" inlet, and 1 1/2" outlet connection. Tubes shall be 1" OD seamless copper tubing with a minimum wall thickness of 0.035" and expanded into the fin collars for maximum fin-tube bond. Inner distributing tubes shall be 5/8" OD seamless copper tubing with a minimum wall thickness of 1/4". All header connections shall be of red brass or steel, with male pipe threads and silver braze to headers. Casing shall be galvanized steel. The core shall be pitched in the direction of the condensate connection for proper drainage.

Testing: The completed coil, including headers and connections, shall be tested underwater with 325 lbs. compressed air to ensure a leak free coil.

2. Diffuser Section [available for YPAL050-105 only]: For applications with an extended discharge plenum for downstream filtration, a diffuser section is provided. A diffuser shall be included to distribute the airflow from the fan evenly across the filter bank to optimize filter life and effectiveness. The diffuser shall be sized for 50% free area and provide adequate upstream and downstream clearance to minimize airside pressure drop.

[FOR EXTENDED DISCHARGE PLENUMS, SELECT ONE OF THE FOLLOWING]

3. Downstream Final Filter Rack [available for YPAL050-105 only]: A 12-inch rigid filter rack and

Guide Specifications (continued)

filters shall be provided downstream of the supply fan and diffuser segment for hospital applications. The filter shall be 90-95% efficient. A magna-helic pressure gauge shall be included and visible from the outside of the unit for servicing and code compliance.

- Blank Section [available for YPAL050-105 only]: A blank section shall be provided downstream of the supply fan and diffuser section.

Condenser Section

- Condenser Fans: Condenser fans shall be matched up with compressors to optimize system control. Condenser fans shall be propeller type, directly driven by permanently lubricated TEAO motor.
- Condenser Coil: Condenser coils shall be seamless copper tubes, arranged in staggered rows, mechanically expanded into the end sheets. Coils are configured in a V-bank configuration, with individual flat coils rotated from the vertical plane for protection from hail damage for each condensing circuit. Condensing coils shall have a subcooler for more efficient, stable operation.
- Compressors: Units shall use industrial-duty hermetic scroll compressors, piped and charged with oil and R22 [R407C available for YPAL050-105 only] refrigerant. Compressors shall have an enlarged liquid carrying capacity to withstand rugged operating conditions. Compressor frame shall be cast iron, with cast iron fixed and orbiting scrolls. Each compressor shall feature a solid state protection module, designed to protect the compressor from over-temperature and over-current conditions. Compressors shall be vibration-isolated from the unit, and installed in an easily accessible area of the unit. All compressor-to-pipe connections shall be brazed to minimize potential for leaks. Each compressor shall include a replaceable suction screen, discharge line check valve, and oil sight glass.
- Low Ambient: Compressors shall operate down to 0°F [optional on YPAL050-105] by monitoring the refrigeration system discharge pressure and adjusting condenser airflow to maintain the proper head pressure to protect compressor operation. Refrigerant pressure transducers shall be included and provide the discharge pressure on the rooftop unit control display.
- In-Line Refrigerant Driers [replaceable core driers]: Refrigerant piping includes check valves, thermal expansion valves with replaceable thermostatic elements, high and low pressure switches, anti-recycling timing device to prevent compressor restart for five minutes after shutdown.
- Freezestat: Freezestats shall be provided to prevent coil freeze up and reduce the risk of liquid flood-back to the compressor.
- Condenser Wire Grill [optional louvered condenser enclosure or no enclosure]: The condenser section shall be enclosed by a wire grill [louvered or none] condenser enclosure on the three exposed sides. Paint finish shall match the color and salt spray specifications of the unit exterior.
- Hot Gas Bypass [optional on constant volume units]: Hot gas bypass piping shall be provided to enable compressor unloading to as low as 5% to better match cooling demand at low loads, prevent excessive cycling of the compressor, and reduce the risk of coil freeze-up.
- Compressor sound treatment [optional]: Compressor sound blankets shall be provided to attenuate radiated sound from the compressors.
- Service Valves [optional]: Liquid, suction and discharge service valves shall be included to provide a means of isolating the refrigerant charge in the system so that the refrigeration system may be serviced without removing the charge of the unit.

Controls

- Enclosure: Unit shall be shipped complete with factory configured, installed, wired and tested rooftop unit controller housed in a rain and dust tight enclosure with hinged, latched, and gasket sealed door.
- Basic Controls: Control shall include automatic start, stop, operating, and protection sequences across the range of scheduled conditions and transients. The rooftop unit controller shall provide automatic control of compressor start/stop, energy saver delay and anti-recycle timers, condenser fans, and unit alarms. Automatic reset to normal operation after power failure. Software stored in non-volatile memory, with programmed setpoints retained in lithium battery backed real time clock (RTC) memory for minimum 5 years. Eighty character liquid crystal display, descriptions and numeric data in English (or Metric) units. The sealed keypad shall include buttons for Setpoints, Display, Entry, Unit Options & clock, and an On/Off Switch.
- Diagnostics: Upon startup, the controller shall run through a self-diagnostic check to verify proper operation and sequence loading. The rooftop unit controller shall continually monitor all input and output points on the controller and to maintain proper operation. The unit shall continue to operate in a trouble mode or shut down as necessary to prevent an unsafe condition for the building occupants, or to prevent damage to the equipment. In the event of a unit shutdown or alarm, the operating condi-

tions, date and time shall be stored in the shutdown history to facilitate service and troubleshooting.

4. Controls and BAS Communications

BACnet MSTP (RS-485) or Modbus: The unit shall include BACnet or Modbus communications directly from the unit controller. Equipment that is not native BACnet at the unit control board shall include any necessary interface or translator device factory-mounted and wired within the unit. If a field-installed gateway device is required by the manufacturer, the manufacturer shall include all necessary materials, equipment, service and commissioning of the gateway. A control points list, BIBBs and PICS statement shall be provided by the manufacturer to facilitate communications programming with the building automation system. Programming, establishing communications and commissioning shall be the responsibility of the installing controls contractor. Start-up assistance and support may be purchased from the manufacturer.

Analog inputs: 0-5VDC inputs shall be provided for remote reset of supply air temperature, and duct static pressure

Binary inputs: Dry (or "wet") contacts shall be provided for alarm outputs for supply fan fault, cooling/heating fault, or general/sensor faults. Contacts shall also be provided for occupied/unoccupied (start/stop) switching; shutdown, smoke purge, exhaust or pressurization operations; call for cooling or heating; and for morning warm-up.

EXECUTION

Installation

General: Installing contractor shall install rooftop unit(s), including components and controls required for operation, in accordance with rooftop unit manufacturer's written instructions and recommendations. Rooftop

units shall be installed as specified.

1. Unit(s) specified shall include a protective covering membrane for such equipment being shipped by truck, rail, or ship. The membrane is fully formed around the equipment exterior. The membrane covers the entire top, side and end panel surface as to protect the product effectively during shipping & storage including "Long Term Storage". Storing on job-site shall no longer require the unit(s) to be covered with a tarp as long as the covering membrane has not been removed.
2. All size or shape equipment including electrical components, especially those not built with weather-proof enclosures, variable-frequency drives and end devices shall be effectively covered for protection against rain, snow, wind, dirt, sun fading, road salt/chemicals, rust, and corrosion during shipping cycle. Equipment shall remain clean and dry.
3. Manufacturers of units not having a protective membrane, fully formed around the equipment exterior, covering the entire top, side and end panel surface area shall be required to ship equipment covered with a tarp, in crating or in a closed truck as is necessary to ensure product protection from road salt/chemicals damage, moisture and dirt infiltration. Arrangements for long term storage at the job site shall be required.

Location: Locate the rooftop unit as indicated on drawings, including cleaning and service maintenance clearance per Manufacturer instructions. Adjust and level the rooftop unit on support structure.

INSPECTION AND START-UP SUPERVISION

A factory-trained service representative of the manufacturer shall supervise the unit startup and application specific calibration of control components.

