

SUBMITTAL DATA: PLA-A36AA & PUZ-A36NHA
36,000 BTU/H CEILING CASSETTE HEAT PUMP SYSTEM

Job Name: _____	Location: _____	Date: _____
Purchaser: _____	Engineer: _____	
Submitted to: _____	For <input type="checkbox"/> Reference <input type="checkbox"/> Approval <input type="checkbox"/> Construction	
Unit Designation: _____	Schedule No.: _____	

GENERAL FEATURES

- Limited Warranty – One year on parts and defects, six years on compressor
- Compact, side discharge outdoor unit
- Quiet operation – indoor and outdoor units
- Auto-restart following a power outage
- Self-check function – onboard diagnostics
- Advanced microprocessor control
- Built-in drain lift mechanism for condensate removal
- Zone control
- Hard-wired, wall-mounted, remote controller (PAR-21MAA)
- 2, 3, or 4 way air flow selection / 6" round or 4 X 14" rectangular branch duct connection
- 4" ventilation air inlet
- Washable filter
- Auto changeover for cooling and heat

OPTIONAL FEATURES

- Multi-function casement
- High efficiency filter element
- Air outlet shutter plate(s)
- Wireless Remote Controller kit
- M-Net adapter
- Wind Baffle
- Air outlet guide

COOLING

Rated capacity 36,000 Btu/h
 Minimum capacity 12,000 Btu/h
 SEER 13.1 Btu/h/W
 Total input. 4510 W
 Power supply 208 / 230V, 1 Phase, 60 Hz
 Breaker size 30 A

HEATING

Rated capacity 37,000 Btu/h
 Minimum capacity 12,000 Btu/h
 Total input. 3490 W
 HSPF (IV/V) (Btu/h/W). 8.3 / 6.7

VOLTAGE

Indoor - outdoor S1-S2 AC 208/230V
 Indoor - outdoor S2-S3 DC 24V
 Indoor - remote controller DC

OPERATING RANGE

	Indoor intake air temp.		Outdoor intake air temp.
Cooling	Max	D.B. 95°F, W.B. 71°F	D.B. 115°F
	Min	D.B. 67°F, W.B. 57°F	D.B. 0°F *
Heating	Max	D.B. 80°F, W.B. 67°F	D.B. 70°F, D.B.59°F
	Min	D.B. 70°F, W.B. 60°F	D.B. 12°F, W.B. 10°F

* With wind baffle installed. If not installed, the minimum temperature will be 23°FDB.

Notes:

INDOOR UNIT

MCA 2 A
 Fan motor 0.79 F.L.A.
 Fan motor output 70 W
 Airflow (Lo-M1-M2-Hi) 710-810-920-990 Dry CFM
 670-770-880-950 Wet CFM
 Sound (level) (Lo-M1-M2-Hi) 28-30-32-34 dB(A)

DIMENSIONS

	UNIT	PANEL
inches	W	33-1/16
	D	33-1/16
	H	10-3/16
mm	W	840
	D	840
	H	258

WEIGHT (unit/panel)

Pounds 66 / 11
 Kg 30 / 5
 Field drain pipe Size I.D. (inches/mm) 1 / 25.4
 Wall-mounted remote controller PAR-21MAA
 (see data submittal sheet)

OUTDOOR UNIT

Compressor DC inverter/twin rotary
 MCA 25
 Fan motor 0.75 F.L.A.
 Sound level. 48 dB(A)

DIMENSIONS

	INCHES	MM
W	37-3/8	950
D	13 + 1-3/16	330 + 30
H	37-1/8	943

Weight (lbs/Kg) 165 / 75
 Refrigerant type R410A
 Refrigerant pipe size O.D. (inches/mm)
 gas side 5/8 / 15.88
 liquid side 3/8 / 9.52
 Max. refrigerant pipe length (ft/m) 165 / 50
 Max. refrigerant pipe height difference (ft/m) 100 / 30
 Connection method flared

NOTES :

*1. Rating conditions (cooling)-indoor : D.B. 80°F, W.B. 67°F outdoor : D.B. 95°F, W.B. 75°F.

*2. Rating conditions (heating)-indoor : D.B. 70°F, W.B. 60°F outdoor : D.B. 17°F, W.B. 15°F.



DIMENSIONS: PLA-A36AA & PUZ-A36NHA

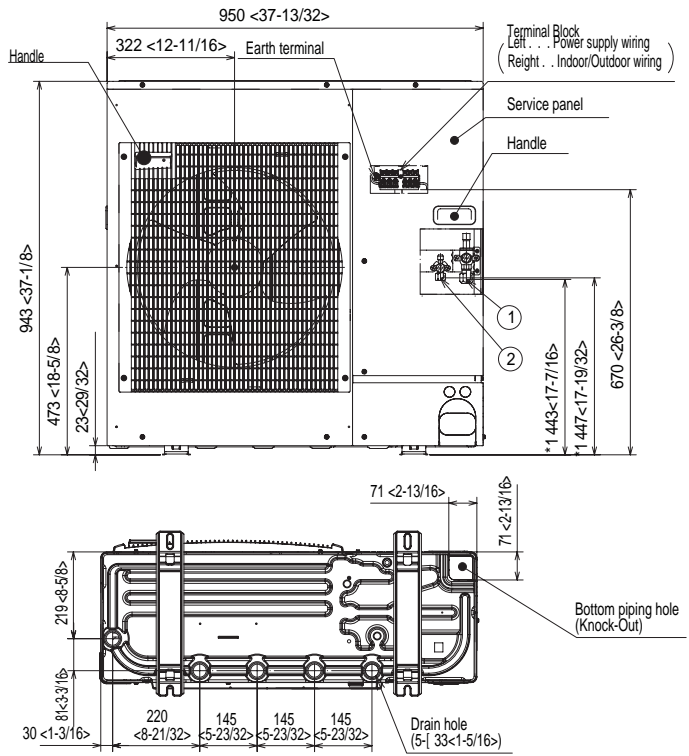
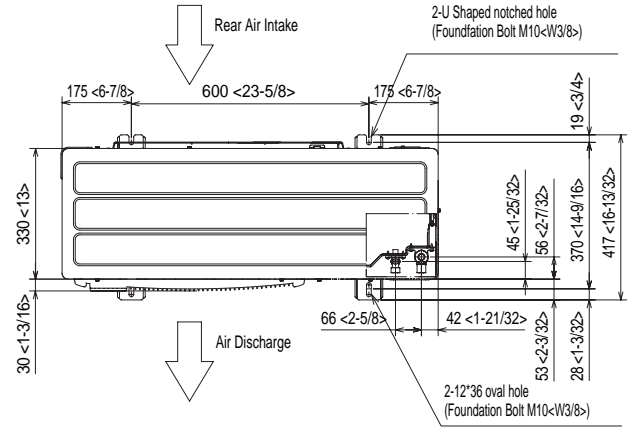
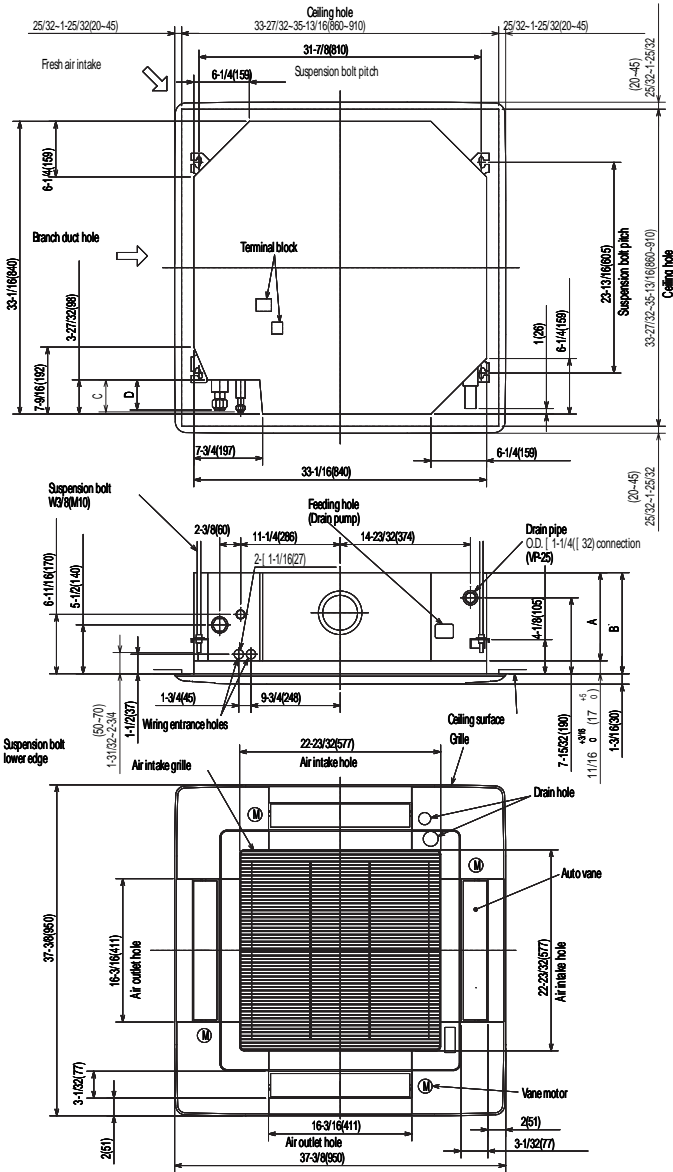

ARI Standard
210/240 UHP



HVAC Advanced Products Division
Mitsubishi Electric & Electronics USA, Inc.

3400 Lawrenceville Suwanee Rd
Suwanee, GA 30024
Tele: 678-376-2900 • Fax: 800-889-9904
Toll Free: 800-433-4822 (#3)

www.mehvac.com
Specifications are subject to change without notice.