

SUBMITTAL

KD 557 SERIES

KD 560 SERIES

KD 564 SERIES

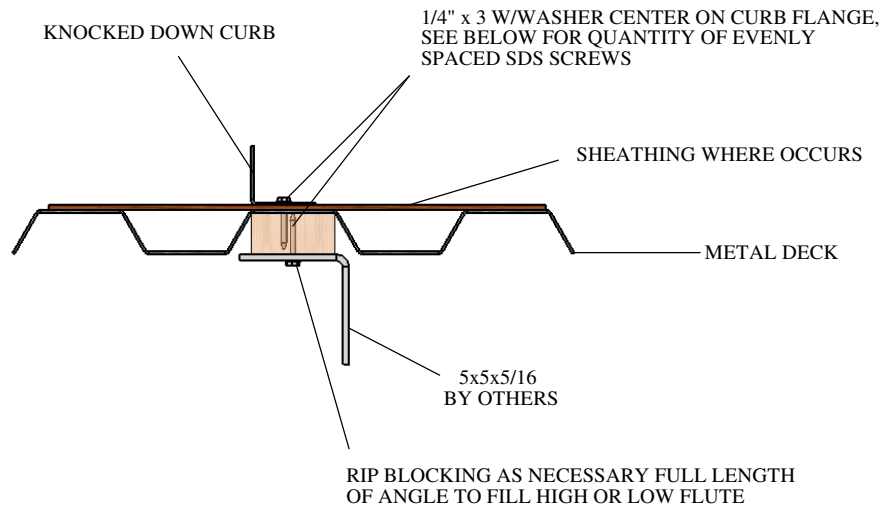

OF SCREWS REQUIRED

CURB	LONG SIDE	SHORT SIDE
0557	7	4
0560	7	4
0564	12	5

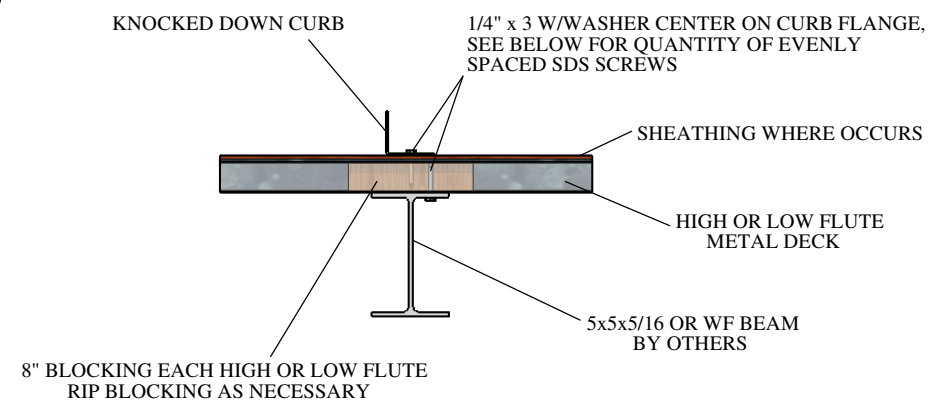

OF SCREWS REQUIRED

CURB	LONG SIDE	SHORT SIDE
0557	7	4
0560	7	4
0564	12	5



PRODUCT NUMBER:
STEEL DECK ANCHORAGE
 FLUTES PERPENDICULAR TO FRAMING

STRUCTURALLY CALCULATED KNOCKED DOWN CURB FOR YORK CURBS KD557, KD560, KD564

Sparks, NV. (800) 884-4662
 Indianapolis, IN. (800) 662-4822
 Longview, TX. (903) 248-4800

DATE: 07/2007
 DRAWN BY: MAC
 WEIGHT: XXX
 MEETS SEISMIC REQUIREMENTS FOR FOLLOWING CODES:
2001 CBC
2006 IBC

THE INFORMATION CONTAINED IN THIS DRAWING IS THE SOLE PROPERTY OF MICROMETL CORPORATION. ANY REPRODUCTION IN PART OR WHOLE WITHOUT THE WRITTEN PERMISSION OF MICROMETL CORPORATION. IS PROHIBITED.