

# SUBMITTAL MicroMetl

## DOWN DISCHARGE ECONOMIZER WITH RELIEF CAPABILITY FOR

YORK ZH, DH, DM, BP 078-150, DR 090-150  
DF 078-120, DJ 150 UNITS

**PART NUMBER:**

**0644ZH712EC**

**DATE:** 08/2007  
**SUBMITTED TO:**  
**COMPANY:** US-AC  
**DRAWN BY:** MAC  
**JOB NAME:**  
**WEIGHT:** 72 LBS  
**NOTES:**

### FEATURES

- \* Fully factory assembled.
- \* Designed specifically for down discharge applications.
- \* Gear driven dampers eliminate slippage associated with standard linkage.
- \* Easy to install and service.
- \* Lower static pressure loss through economizer dampers.
- \* Greater barometric relief capabilities.
- \* Factory assembled rainhood.
- \* Rainhoods are sloped for water run-off.

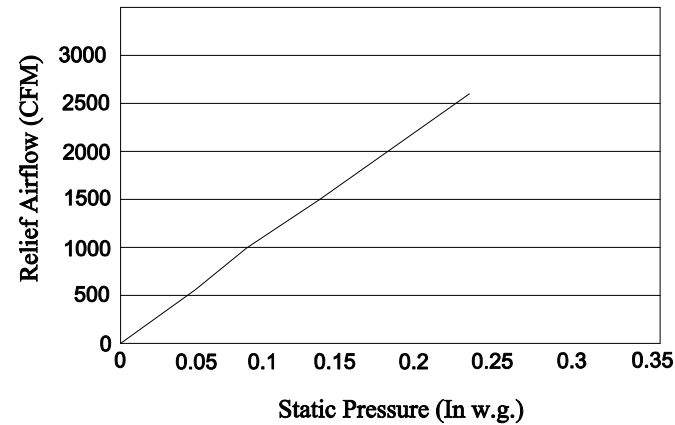

Economizer includes Honeywell W7212 controller capable of CO2 demand control and power exhaust activation switch.

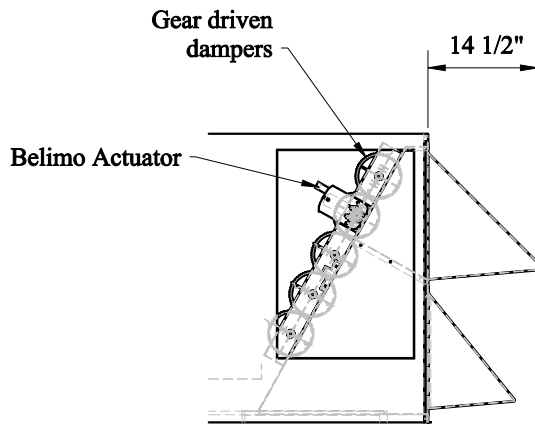

**SIDE VIEW**

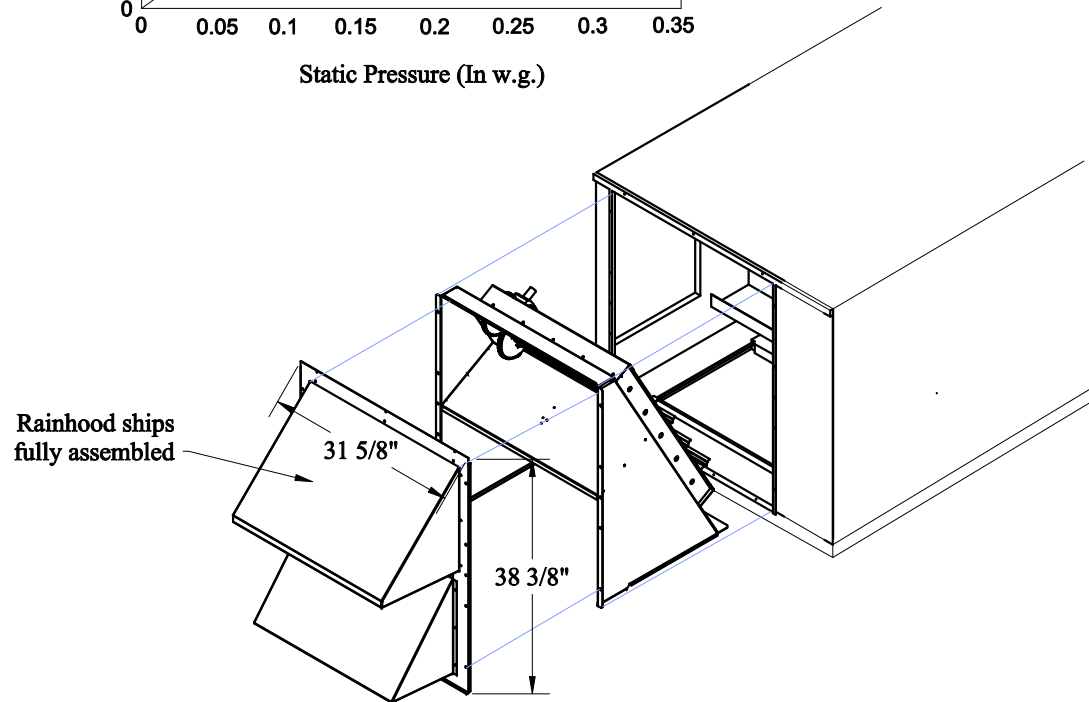

THIS DOCUMENT IS THE PROPERTY OF MICROMETL CORPORATION AND IS DELIVERED UPON THE EXPRESS CONDITION THAT THE CONTENTS WILL NOT BE DISCLOSED OR USED WITHOUT MICROMETL'S WRITTEN CONSENT. MANUFACTURER RESERVES THE RIGHT TO DISCONTINUE, OR CHANGE AT ANYTIME, SPECIFICATIONS & DESIGNS WITHOUT ANY NOTICE AND WITHOUT INCURRING OBLIGATIONS. COPYRIGHT MICROMETL CORPORATION 1999. ALL RIGHTS RESERVED

MICROMETL CORPORATION \* 3035 N. SHADELAND AVE., SUITE 300 \* INDIANAPOLIS, IN 46226 \* 1-800-862-4822 \*\*\* MICROMETL WEST \* 905 SOUTHERN WAY \* SPARKS, NV \* 1-800-884-4662