



TECHNICAL GUIDE

SPLIT-SYSTEM AIR-COOLED

EVAPORATOR BLOWER

25, 30, 40 & 50 TON

LA300, LB360, 480 & 600

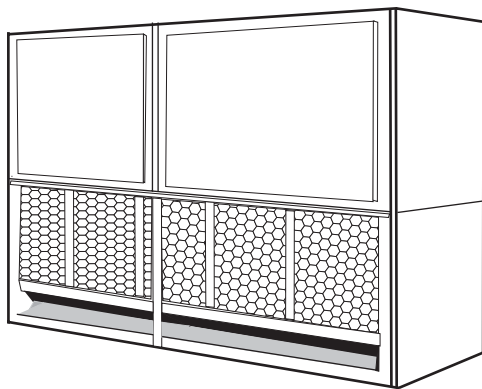

PROVEN PERFORMANCE

GENERAL

The LA/LB line is a flexible performer. LA300, LB360 & 480 can be positioned in up to 12 different positions and suspended in various positions. The LB600 can be positioned in up to 7 different arrangements and suspended also. The LA/LB line will give you the power to condition large amounts of building space and the ability to conform to almost any situation.

FEATURING

- EASE OF SERVICE
- PUMP-OUT ON START-UP
- BASE SECTIONS (25, 30 & 40 Ton only)
- SUSPENSION PACKAGES
- HOT WATER COILS
- STEAM COILS (LA300 & LB360 only)
- WIDE RANGE OF BLOWER MOTORS
- A VARIETY OF DRIVE PACKAGES
- CONTROL BOX WITH LOW VOLTAGE TRANSFORMER AND MOTOR STARTER (motor, motor drive kit and motor overloads sold separately).



TABLE OF CONTENTS

DESCRIPTION	4
MODULAR DESIGN	4
FACTORY-MOUNTED COMPONENTS	4
ACCESSORIES	4
GUIDE SPECIFICATIONS	23

LIST OF FIGURES

<u>Fig.</u>		<u>Pg.</u>
1	PRODUCT NOMENCLATURE	3
2	UNIT INSTALLATION	4
3	DETAILS FOR SECURING BOTTOM MOUNTING SUPPORTS	6
4	LA300/LB360 WEIGHT DISTRIBUTION	6
5	UNIT DIMENSIONS - LA300, LB360 & LB480	11
6	25 TON LIQUID LINE SOLENOID WIRING	11
7	30, 40 & 50 TON LIQUID LINE SOLENOID WIRING	11
8	LA300 PIPING CONNECTIONS	12
9	LB360 PIPING CONNECTIONS	12
10	LB480 PIPING CONNECTIONS	12
11	UNIT DIMENSIONS - LB600	13
12	LB600 PIPING CONNECTIONS - END PANEL DETAIL	13
13	HOT WATER COIL DIMENSIONS	14
14	STEAM COIL DIMENSIONS	14
15	BASE SECTION DIMENSIONS	14
16	BLOWER CURVE LA300 & LB360	19
17	BLOWER CURVE LB480	21
18	BLOWER CURVE LB600	22

LIST OF TABLES

<u>Tbl.</u>		<u>Pg.</u>
1	STATIC RESISTANCES FOR UNIT ACCESSORIES ..	5
2	UNIT MOUNTING DIMENSIONS	5
3	CORNER WEIGHTS	7
4	ACCESSORY OPERATING WEIGHT DISTRIBUTION (LBS)	7
5	UNIT BLOWER MOTOR DATA	7
6	UNIT DRIVE DATA	8
7	MOTOR OVERLOAD ELEMENTS	8
8	HOT WATER COIL CAPACITIES	9
9	HOT WATER COIL CAPACITY CORRECTION AND PRESSURE DROP VS GPM	9
10	STEAM COIL CAPACITIES, MBH @ 2 PSIG	10
11	CORRECTION FACTORS FOR HIGH STEAM	10
12	UNIT DIMENSIONS - LA300, LB360, LB480	11
13	UNIT CONNECTION SIZES	12
14	HOT WATER COIL DIMENSIONS	14
15	STEAM COIL DIMENSIONS	14
16	BASE SECTIONS DIMENSIONS	14
17	PHYSICAL DATA	15
18	ELECTRICAL DATA	17
19	FAN PERFORMANCE DATA - 25 TON	18
20	FAN PERFORMANCE DATA - 30 TON	18
21	FAN PERFORMANCE DATA - 40 TON	20
22	FAN PERFORMANCE DATA - 50 TON	20

YORK SPLIT INDOOR PRODUCT NOMENCLATURE

L A 300 C 00 A 6 A AA 1 A

Model #	Model Number Description	Options
L	Product Category	L = Air Handling Unit - Cooling F = Air Handling Unit - Heat Pump
A	Product Identifier	A = R-22 Standard Efficiency 2-Pipe B = R-22 Standard Efficiency 4-Pipe
300	Nominal Cooling Capacity MBH	300 = 25 Ton 360 = 30 Ton 480 = 40 Ton 600 = 50 Ton
C	Heat Type	C = Cooling Only
00	Nominal Heating Capacity	00 = No Heat Installed
A	Airflow Options	A = None
6	Voltage	0 = None 5 = 575-3-60 6 = 208/230-460-3-60
A	Factory Options	A = None
AA	Special Options	AA = None
1	Product Generation	1 = First Generation 2 = Second Generation

FIGURE 1 - PRODUCT NOMENCLATURE

NOTE: LB600 matches with both HB480 and HB600 Outdoor Condensing Units for maximum efficiency.

NOTE: LB480 Indoor and HB480 Outdoor Units do match up, but do not meet ASHRAE 90.1 standards for efficiency.

DESCRIPTION

Evaporator blower units are designed with two distinct modules to provide maximum application flexibility. The 25, 30 and 40 ton units are shipped as single packages with the blower module mounted on top of the coil module. The blower module can be repositioned in the field to meet almost any installation requirement. Blower and coil modules for the 50 ton units are shipped separately to simplify handling. These modules can be connected in the field with the same flexibility as the smaller units.

The blower module includes the blower wheels and room for a field-mounted motor and drive. The coil module includes direct expansion coils, 2 in. throwaway filters, liquid line solenoid valves for both capacity reduction and pumpdown, thermal expansion valves, distributors and a condensate drain pan.

Every evaporator coil is pressurized with air to 325 psig and leak tested under water. After the headers are brazed onto the coil and the coil is installed in the unit, the coil is pressurized with a combination of Refrigerant-22 and nitrogen to 150 psig for pressure testing and additional leak testing. After the coil is evacuated and dehydrated, it is pressurized with a holding charge of Refrigerant-22 for storage and/or shipping.

Steam coils, hot water coils, base sections, suspension hardware, blower motors and drive packages are available as field-installed accessories to provide additional application flexibility.

These evaporator blowers, combined with condensing units, provide years of quiet, efficient and dependable operation. These units are manufactured under ISO 9001 Quality System Certification.

For Indoor Unit Installation details, please see document 035-18496-000.

MODULAR DESIGN

These evaporator blowers can be arranged for a variety of air discharge patterns in either the horizontal or vertical position.

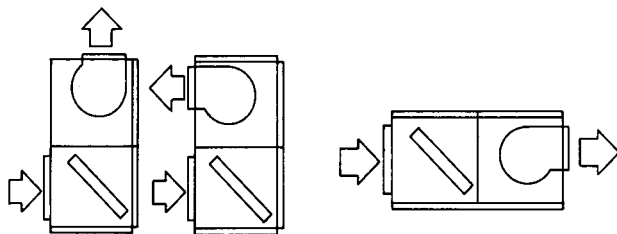

FIGURE 2 - UNIT INSTALLATION

Figure 2 shows three of the common installation arrangements. Refer to the unit installation instructions for other possibilities.

Units may be bottom-supported or ceiling-suspended and can be arranged to meet almost any space or duct requirements. Each unit is available with a choice of blower motors, drive packages and other accessories to make them suitable for most applications.

FACTORY-MOUNTED COMPONENTS

PART LOAD OPERATION These evaporator blowers have multiple coils with pre-piped distributors, expansion valves and solenoid valves. Field modifications are not required for part load operations. Capacity reduction not only provides economical operation, but also maintains more even temperature and humidity levels in the conditioned space.

EASY SERVICE Serviceable expansion valves are provided on every unit. These superior valves are factory-installed to provide many years of trouble-free operation. If service is required, it is not necessary to unbrazed any joints.

PUMP-OUT Evaporator blowers include a solenoid valve for non-recycling pump-out. When a cooling requirement in the conditioned space is needed, the refrigerant is pumped into the high side of the system before unit start-up.

ACCESSORIES

BASE SECTIONS (25, 30 and 40 ton only): Base sections can be used to elevate units above the floor. If desired, outdoor air may be introduced through these sections by cutting an access opening to accommodate the outdoor air duct connection. These bases have a durable finish to match the evaporator blower unit. They may have to be insulated for certain applications.

SUSPENSION PACKAGES: These accessories can be used to suspend horizontal units from above without interfering with access to the unit. They can also be used for elevating a floor-mounted unit (either horizontal or vertical) to provide additional height for the installation of a trap at the condensate drain connection. All suspension packages can be used with vibration isolators.

HOT WATER COILS: Drainable water coils are available for field installation between the blower and the coil modules of both horizontal and vertical units. Since their casings match the dimensions and the finish of the basic units, they become an integral part of the unit after installation. The coils slide out of their casings for easy installation. Coils have copper tubes that have been mechanically expanded into aluminum fins. Both headers are located on the same end of the coil. Coils are leak-tested at 325 psig under water and dried before their connections are capped for storage and shipping.

STEAM COILS (LA300 & LB360 only): A steam coil is available on the 25 & 30 Ton for installation between the blower and coil modules of both horizontal and vertical units. Since the casing matches the dimensions and the finish of the basic unit, it becomes an integral part of the unit after installation. The coil slides out of the casings for easy installation and is pitched in the casings to facilitate condensate drainage. The coil has copper tubes that have been mechanically expanded into aluminum fins. Both headers are located on the same end of the coil. The coil is leak-tested at 325 psig and dried before the connections are capped for storage and shipping.

BLOWER MOTORS: Different HP motors are available for each unit to meet almost any air delivery requirement. All motors are UL approved, have permanently lubricated ball bearings and are field-mounted within the insulated cabinet of the units to minimize the transmission of sound to the sur-

rounding space. 5 HP motors are inherently protected. 7.5 HP - 15 HP require motor overload protection. **Power wiring for blower motor is field supplied.**

DRIVE PACKAGES: Different size pulleys and belts are available for each unit to provide a blower RPM range to meet almost any air delivery requirement. Variable pitch motor pulleys can be adjusted to provide the proper blower RPM. All drive packages are rated at least 25% above the nominal HP rating of the blower motor. Two-groove pulleys and two belts are provided on every drive package rated at 5 HP and above.

STARTERS AND HEATER ELEMENTS (7.5 - 15 HP): The blower motors that are available for the units do not have inherent protection and require external motor overload protection. See details in Table 7.

TABLE 1: STATIC RESISTANCES FOR UNIT ACCESSORIES

UNIT MODEL	ACCESSORY	CFM				
		8,000	9,000	10,000	11,000	12,000
LA300	Hot Water Coil	0.06	0.07	0.08	0.09	0.10
	Steam Coil	0.11	0.14	0.17	0.20	0.23
LB360	Hot Water Coil	0.08	0.09	0.10	0.12	0.14
	Steam Coil	0.17	0.20	0.23	0.27	0.31
LB480	Hot Water Coil	0.11	0.13	0.15	0.17	0.20
	Hot Water Coil	0.15	0.18	0.21	0.24	0.28

TABLE 2: UNIT MOUNTING DIMENSIONS¹

LA/LB UNIT	DIMENSIONS, INCHES		
	AX	BX	CX
300	69-1/4	49-1/16	26-5/8
360	69-1/4	49-1/16	26-5/8
480	84	50-9/16	34

¹ See Figure 4 for dimensions AX, BX and CX.

TABLE 3: CORNER WEIGHTS

UNIT-MODEL	Unit Weight		Configuration	A	B	C	D
	Shipping	Operation					
LA300	1180	1125	HORIZONTAL	276	317	285	247
			VERTICAL	262	301	301	262
LB360	1180	1146	HORIZONTAL	281	323	290	252
			VERTICAL	266	307	307	266
LB480	1510	1426	HORIZONTAL	348	414	361	303
			VERTICAL	292	348	427	359
LB600	1572	1640	HORIZONTAL	451	386	370	433
			VERTICAL	484	414	342	400

TABLE 4: ACCESSORY OPERATING WEIGHT DISTRIBUTION (LBS)¹

ACCESSORY	LA300	LB360	LB480	LB600
BASE ²	25	25	30	45
HOT WATER COIL	35	35	45	35
STEAM COIL 1 ROW	30	30	35	50

1. These weights should be added to each point load in table 3.

2. This accessory can only be applied on units installed in the vertical position.

TABLE 5: UNIT BLOWER MOTOR DATA

UNIT MODEL	HP	MOTOR KIT MODEL NUMBER	FRAMESIZE	VOLTAGE (3PH-60HZ)
LA300	5	2LR04605032	184	230/460
		2LR04605023		208
		2LP04605158		575
	7.5	2LP04607133	213	230/460
		2LP04607158		575
	LB360	5	2LR04605032	184
2LR04605023			208	
2LR04605158			575	
7.5		2LP04607133	213	208/230/460
		2LP04607158		575
10		2LP04610133	215	208/230/460
		2LP04610158		575
LB480		7.5	2LP04607133	213
	2LP04607158		575	
	10	2LP04610133	215	208/230/460
		2LP04610158		575
LB600	10	2LP04610133	215	208/230/460
		2LP04610158		575
	15	2LP04615133	254	208/230/460
		2LP04615158		575

TABLE 6: UNIT DRIVE DATA

UNIT MODEL	DRIVE KIT MODEL NUMBER	BLOWER RPM RANGE	ADJUSTABLE MOTOR PULLEY		FIXED BLOWER PULLEY		BELTS		
			PITCH DIA. (IN.)	BORE (IN.)	PITCH DIA. (IN.)	BORE (IN.)	QTY.	PITCH LENGTH (IN.)	DESIGNATION
LA300	1LD0440	600 - 750	4.0 - 5.0	1 1/8	12.0	1 3/16	2	63.3	A62
	1LD0407	700 - 850	4.2 - 5.2	1 3/8	11.0	1 3/16	2	63.3	A62
	1LD0442	780 - 940	5.3 - 6.3	1 3/8	12.0	1 3/16	2	63.3	A62
LB360	1LD0415	636 - 795	4.0 - 5.0	1 1/8	11.0	1 3/16	2	63.3	A62
	1LD0407	668 - 827	4.2 - 5.2	1 3/8	11.0	1 3/16	2	63.3	A62
	1LD0408	827 - 986	5.3 - 6.3	1 3/8	11.0	1 3/16	2	59.7	A59
LB480	1LD0409	607 - 776	4.3 - 5.5	1 3/8	12.4	1 3/16	2	85.1	B84
	1LD0410	776 - 917	5.4 - 6.6	1 3/8	12.4	1 3/16	2	86.8	B85
LB600	1LD0411	692 - 833	4.8 - 6.0	1 3/8	12.4	1 3/16	2	78.6	B78
	1LD0412	762 - 931	5.4 - 6.6	1 5/8	12.4	1 3/16	2	76.8	B75

TABLE 7: MOTOR OVERLOAD ELEMENTS¹

MOTOR HP	VOLTAGE	MODEL NUMBER
5	208	2MP04704600
	230	2MP04704600
	460	2MP04704900
	575	2MP04705000
7.5	208	2MP04703700
	230	2MP04704500
	460	2MP04704300
	575	2MP04704000
10	208	2MP04701600
	230	2MP04704100
	460	2MP04704200
	575	2MP04704300
15	208	2MP04704400
	230	2MP04701700
	460	2MP04704500
	575	2MP04704600

¹ These units are equipped from the factory with a correctly sized motor starter; overload elements are not factory supplied.

Note: Three elements required per unit.

CAUTION

Do not operate the supply air blower motor above its nominal HP rating when a unit is equipped with a hot water coil accessory. Do not use steam in hot water coils.

CAUTION

Do not operate the supply air blower above its nominal HP rating when a unit is equipped with a steam coil accessory.

Although these coils are suitable for a much higher pressure, steam above 25 psig provides too much heat that could damage the blower motor.

TABLE 8: HOT WATER COIL CAPACITIES¹

UNIT MODEL	HOT WATER COIL MODEL	GPM	CFM	ENTERING WATER TEMPERATURE MINUS ENTRY AIR TEMPERATURE °F.				
				70	90	110	130	150
LA300	1HW0406	50	6,000	204	263	325	384	443
			8,000	236	304	372	440	508
			10,000	265	341	416	492	568
			12,000	291	374	457	540	623
LB360		50	8,000	236	304	372	440	508
			10,000	265	341	416	492	568
			12,000	291	374	457	540	623
			14,000	315	405	495	585	675
LB480	1HW0407	75	12,800	348	447	547	646	746
			16,000	389	500	611	722	833
			19,200	425	547	668	790	911
LB600		75	16,000	389	500	611	722	833
			20,000	436	561	686	810	935
			24,000	473	610	746	882	1,019

¹. These capacities do not include any blower motor heat.
NOTE: Temperature Water Drop (°F) = (2 X MBH) / GPM.

TABLE 9: HOT WATER COIL CAPACITY CORRECTION AND PRESSURE DROP VS GPM¹

HOT WATER COIL MODEL	GPM	PRESSURE DROP PSI	CAPACITY CORRECTION FACTOR
1HW0406	25	0.4	0.79
	50	1.0	1.00
	75	1.8	1.04
	100	3.4	1.07
1HW0407	50	1.0	0.95
	75	1.5	1.00
	100	2.4	1.03
	125	3.5	1.05

¹. For pressure drop in feet (water), multiply these values by 2.31.

TABLE 10: STEAM COIL CAPACITIES¹, MBH @ 2 PSIG²

UNIT MODEL	STEAM COIL MODEL	CFM	DRY BULB TEMPERATURE OF AIR ENTERING COIL (°F)			
			10	30	50	70
LA300	1NF0454	6,000	471	424	380	330
		8,000	535	483	432	380
		10,000	592	535	478	422
		12,000	642	580	518	456
LB360		8,000	535	483	432	380
		10,000	592	535	478	422
		12,000	642	580	518	456
		14,000	687	621	555	489

1. These capacities do not include any blower motor heat.

2. Multiply these capacities by the factors in Table 11 to correct for higher steam pressure.

TABLE 11: CORRECTION FACTORS FOR HIGH STEAM

STEAM PRESSURE (PSIG)	5	10	15	20	25
CAPACITY CORRECTION FACTOR	1.05	1.12	1.19	1.25	1.30

NOTE: Steam Rate = (lbs/Hr.) = 1.025 x MBH

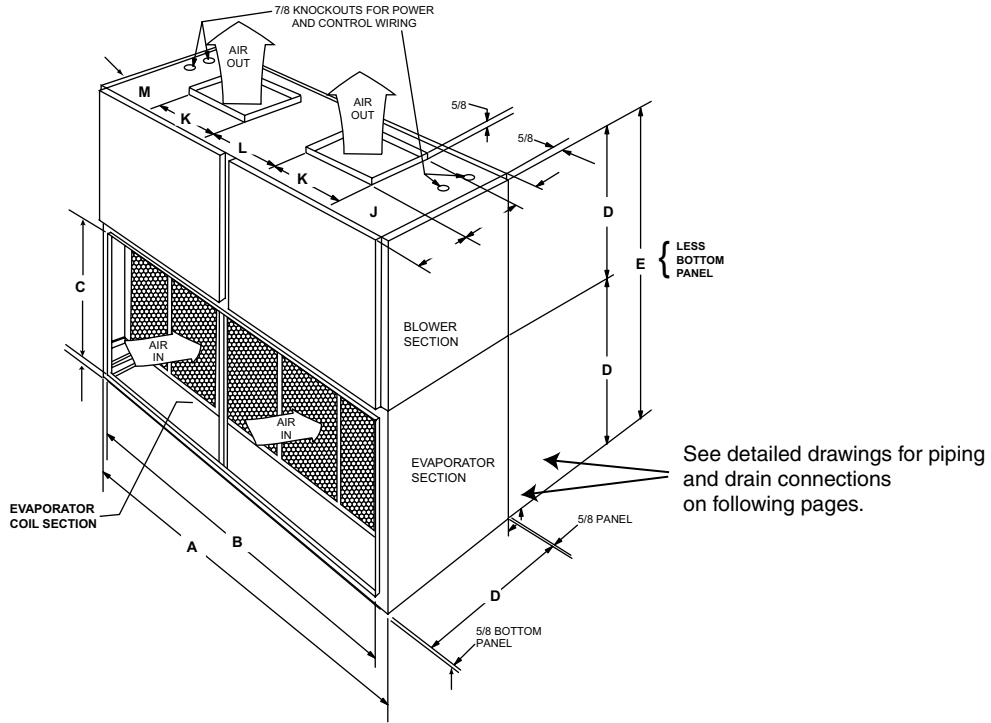

FIGURE 5 - UNIT DIMENSIONS - LA300, LB360 & LB480

TABLE 12: UNIT DIMENSIONS - LA300, LB360, LB480

MODEL	A	B	C	D	E	F	G	H	J	K	L	M
LA300	100-1/8	95-5/8	33-1/4	36-5/8	74	2-1/2	18-7/8	16-1/2	15-13/16	21-7/8	18	22-9/16
LB360	100-1/8	95-5/8	33-1/4	36-5/8	74	2-1/2	18-7/8	16-1/2	15-13/16	21-7/8	18	22-9/16
LB480	103-1/8	95-5/8	40-5/8	44	88-5/8	2-1/2	18-7/8	23-7/8	20-11/16	21-7/8	18	22-11/16

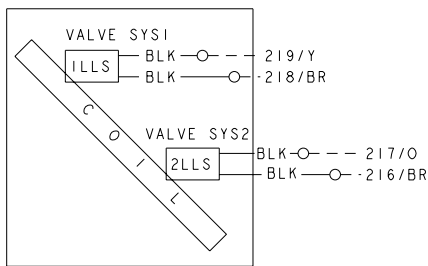

FIGURE 6 - 25 TON LIQUID LINE SOLENOID WIRING

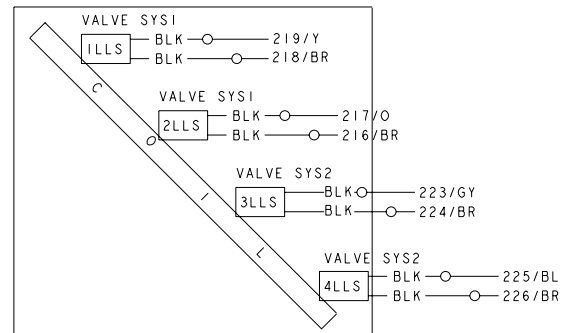

FIGURE 7 - 30, 40 & 50 TON LIQUID LINE SOLENOID WIRING

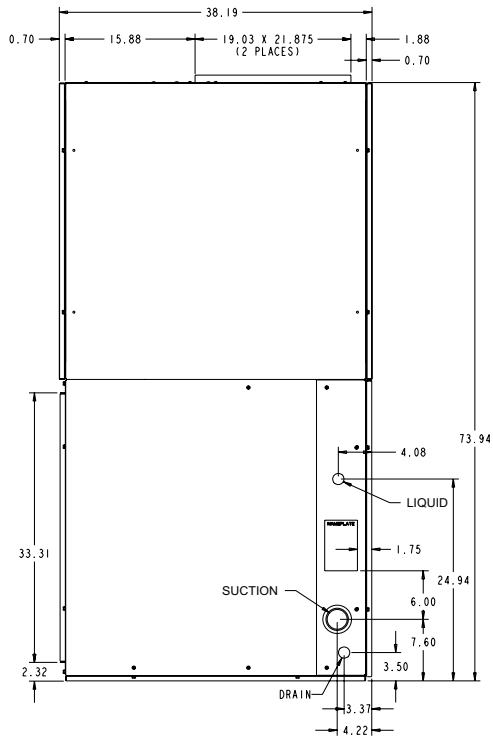

FIGURE 8 - LA300 PIPING CONNECTIONS

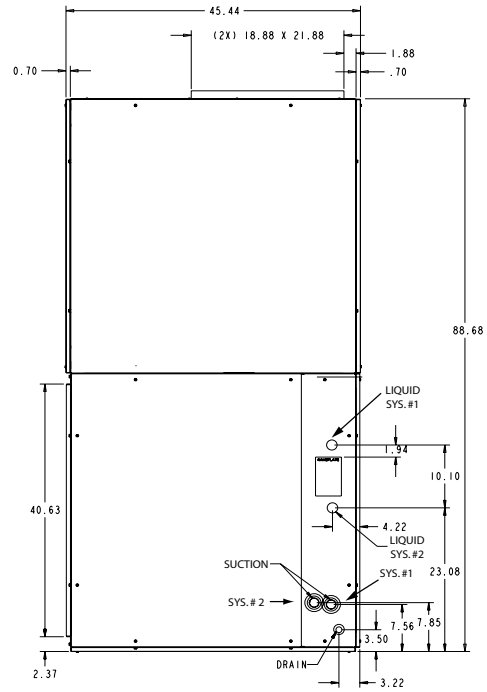

FIGURE 10 - LB480 PIPING CONNECTIONS

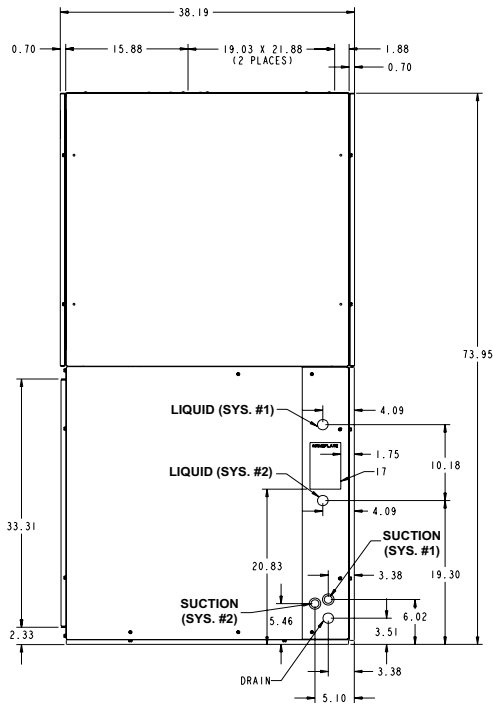

FIGURE 9 - LB360 PIPING CONNECTIONS

TABLE 13: UNIT CONNECTION SIZES

Connection Entry	Connection Size			
	LA300	LB360	LB480	LB600 + M2CX600
Suction Line Sys # 1	2 1/8	1-1/8	1-3/8	2-1/8
Suction Line Sys # 2	N/A	1-1/8	1-3/8	2-1/8
Liquid Line Sys # 1	7/8	7/8	7/8	7/8
Liquid Line Sys # 2	N/A	7/8	7/8	7/8
Power Wiring	7/8 (2)	7/8 (2)	7/8 (2)	1-3/8
Control Wiring	7/8 (2)	7/8 (2)	7/8 (2)	7/8 (2)

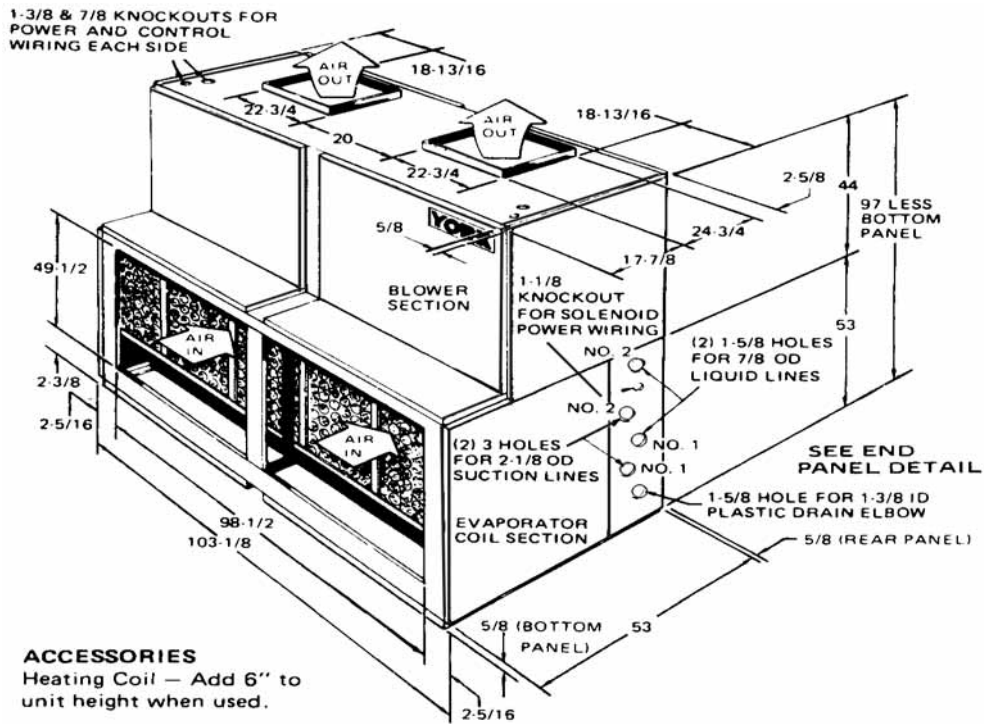

FIGURE 11 - UNIT DIMENSIONS - LB600

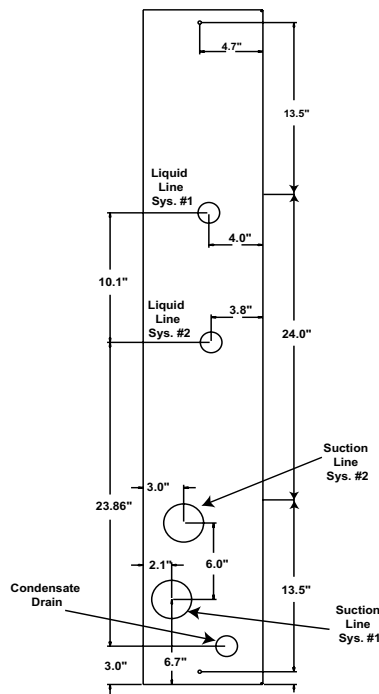

FIGURE 12 - LB600 PIPING CONNECTIONS - END PANEL DETAIL

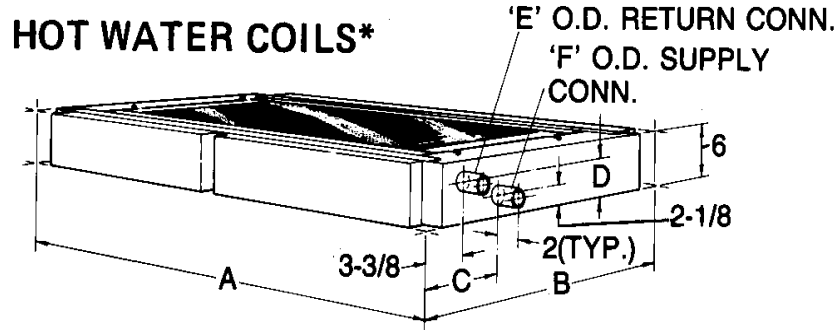

FIGURE 13 - HOT WATER COIL DIMENSIONS

TABLE 14: HOT WATER COIL DIMENSIONS

COIL MODEL	UNIT MODEL	DIMENSIONS					
		A	B	C	D	E	F
1HW0406	LA300 LB360	100-1/8	37-7/8	6-3/4	3-7/8	1-3/8	1-3/8
1HW0407	LB480 LB600	103-1/8	45-1/4	6-1/2	4	1-5/8	1-5/8

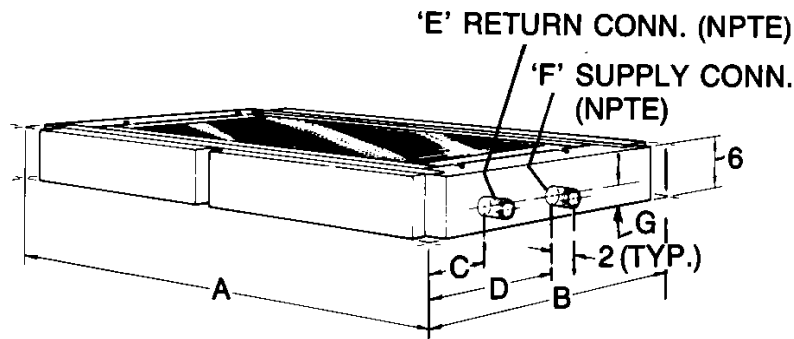

FIGURE 14 - STEAM COIL DIMENSIONS

TABLE 15: STEAM COIL DIMENSIONS¹

COIL MODEL	UNIT MODEL	DIMENSIONS						
		A	B	C	D	E	F	G
1NF0454	LA300 LB360	100-1/8	37-7/8	4-3/8	18-3/8	1-1/2	2	2-1/2

¹. Coils are field-installed between the evaporator coil and the blower section of the unit.

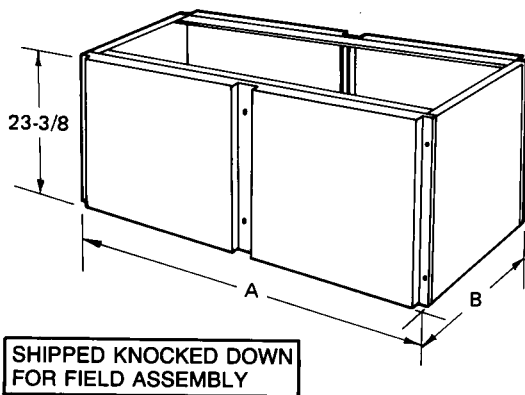

FIGURE 15 - BASE SECTION DIMENSIONS

TABLE 16: BASE SECTIONS DIMENSIONS¹

BASE MODEL	UNIT MODEL	DIMENSIONS	
		A	B
1BS0406	LA300 LB360	100-1/8	37-7/8
1BS0407	LB480	103-1/8	45-1/4

¹. Ventilation air can be brought into the unit through the base section providing the base section is fully insulated in the field.

TABLE 17: PHYSICAL DATA

DESCRIPTION			MODEL			
			LA300	LB360	LB480	LB600
EVAPORATOR COIL	Rows Deep X Rows High		4 x 40	4 x 40	4 x 50	4 x 62
	Finned Length, Inches		93	93	96	96
	Face Area, Feet ²		25.8	25.8	33.3	41.3
	Tube (copper) OD, Inches		3/8	3/8	3/8	3/8
	Fins (Aluminum) per 1 inch		16	16	16	16
	Piping Connections, Inches	Liquid, Inches	7/8	7/8	7/8	7/8
	Suction, Inches	2 1/8	1 1/8	1 3/8	2 1/8	
CENTRIFUGAL BLOWERS (2 PER UNIT)	Diameter X Width, Inches (Forward Curved)		18 x 18			20 x 18
FILTERS (THROWAWAY)	16 x 20 x 2		-	-	6	-
	20 x 20 x 2		-	-	3	-
	20 x 22 x 2		-	-	-	-
	16 x 25 x 2		-	-	-	6
	20 x 25 x 2		10	-	6	3
	25 x 25 x 2		-	-	-	6
Total Face Area / feet ²		34.7			42.6	53.1
OPERATING CHARGE (LBS R-22)	System 1		49.65	30.08	37.83	46.59
	System 2		-	30.08	37.83	46.59
DRAINABLE HOT WATER COIL ACCESSORY	Tube (copper) OD, Inches		1/2		1/2	1/2
	Rows Deep		2		2	2
	Fins (Aluminum) per 1 inch		12		12	8
	Face Area, Feet ²		21.2		27.2	27.2
	Connections (Supply & Return), Inches		1 3/8 OD (Copper)		1 5/8 OD (Copper)	
	NON-FREEZE, STEAM DISTRIBUTING COIL ACCESSORY	Tube (copper) OD, inches		1 (Outside) 5/8 (Inside)		
Rows Deep		1				
Fins (Aluminum) per 1 inch		8				
Face Area, feet ²		18.2				
Connection, (Brass) Inches (NPTE)		Inlet	2			
	Outlet	1-1/2				

TABLE 17: PHYSICAL DATA

DESCRIPTION		MODEL				
		LA300	LB360	LB480	LB600	
COMPONENT WEIGHT	Basic Unit (Less Motor & Drive)		980	980	1260	1474
	Shipping Weight (lbs)		1180	1180	1510	1572
	Operating Weight (lbs)		1125	1146	1426	1640
	Accessories	Hot Water Coil	150	150	190	190
		Steam Coil	160	160	-	-
	Blower Motor (1750 RPM)		117 (5hp)	117 (5hp)	-	-
120 (7.5hp)			120 (7.5hp)	120 (7.5hp)	141 (10hp)	
		-	141 (10hp)	141 (10hp)	217 (15hp)	

TABLE 18: ELECTRICAL DATA

UNIT MODEL	HP	FLA	VOLTAGE (3PH-60HZ)	MIN. CIRCUIT AMPACITY	MAX. FUSE SIZE (Amps)
LA300	5	16.7	208	21	35
		15.2	230	19	30
		7.6	460	10	15
		6.1	575	8	15
	7.5	24.2	208	30	50
		22	230	28	45
		11	460	14	20
		9	575	11	20
LB360	5.0	16.7	208	21	35
		15.2	230	19	30
		7.6	460	10	15
		6.1	575	8	15
	7.5	24.2	208	30	50
		22	230	28	45
		11	460	14	20
		9	575	11	20
	10	30.8	208	39	60
		28	230	35	60
		14	460	18	30
		11	575	14	20
LB480	7.5	24.2	208	30	50
		22	230	28	45
		11	460	14	20
		9	575	11	20
	10	30.8	208	39	60
		28	230	35	60
		14	460	18	30
		11	575	14	20
LB600	10	30.8	208	39	60
		28	230	35	60
		14	460	18	30
		11	575	14	20
	15	46.2	208	58	100
		42	230	53	90
		21	460	26	45
		17	575	21	35

TABLE 19: FAN PERFORMANCE DATA - 25 TON¹

RPM	CFM														
	8,000			9,000			10,000			11,000			12,000		
	SP ²	BHP ³	κW	SP ²	BHP ³	κW	SP ²	BHP ³	κW	SP ²	BHP ³	κW	SP ²	BHP ³	κW
600	-	-	-	0.30	2.5	2.3	0.20	3.1	2.9	0.02	3.6	3.4	-	-	-
635	0.56	2.4	2.3	0.43	2.7	2.6	0.31	3.3	3.1	0.13	3.8	3.5	-	-	-
700	0.80	3.0	2.8	0.68	3.3	3.1	0.54	3.7	3.5	0.38	4.2	3.9	0.20	4.8	4.5
775	1.12	3.7	3.4	1.00	4.0	3.7	0.85	4.4	4.1	0.70	4.8	4.5	0.54	5.3	5.0
800	1.23	3.9	3.7	1.11	4.3	4.0	0.97	4.7	4.4	0.82	5.1	4.8	0.66	5.6	5.2
875	1.60	4.8	4.5	1.48	5.1	4.8	1.34	5.6	5.2	1.19	6.0	5.7	1.04	6.6	6.2
900	1.73	5.1	4.8	1.61	5.5	5.1	1.47	5.9	5.5	1.33	6.4	6.0	1.17	7.0	6.5
940	1.95	5.6	5.2	1.82	6.0	5.6	1.70	6.5	6.1	-	-	-	-	-	-

1. Unit resistance is based on a dry evaporator coil and clean filters.
2. Available static pressure in IWG to overcome the resistance of the duct system and any accessories added to the unit. Refer to the blower motor and drive table and the accessory static resistance table for additional information.
3. Motors can be selected to operate into the service factor because they are located in the moving air stream, upstream of any heating device. units with steam or hot water coils are the only exception. On these units, the BHP must not exceed the nominal HP rating of the motor.

TABLE 20: FAN PERFORMANCE DATA - 30 TON¹

RPM	CFM														
	10,000			11,000			12,000			13,000			14,000		
	SP ²	BHP ³	κW	SP ²	BHP ³	κW	SP ²	BHP ³	κW	SP ²	BHP ³	κW	SP ²	BHP ³	κW
600	0.20	3.1	2.9	0.02	3.6	3.4	-	-	-	-	-	-	-	-	-
635	0.31	3.3	3.1	0.13	3.8	3.5	-	-	-	-	-	-	-	-	-
700	0.54	3.7	3.5	0.38	4.2	3.9	0.20	4.8	4.5	0.03	5.3	5.0	-	-	-
775	0.85	4.4	4.1	0.70	4.8	4.5	0.54	5.3	5.0	0.39	5.8	5.5	0.20	6.4	6.0
800	0.97	4.7	4.4	0.82	5.1	4.8	0.66	5.6	5.2	0.52	6.1	5.7	0.35	6.7	6.3
875	1.34	5.6	5.2	1.19	6.0	5.7	1.04	6.6	6.2	0.93	7.1	6.6	0.77	7.7	7.2
900	1.47	5.9	5.5	1.33	6.4	6.0	1.17	7.0	6.5	1.07	7.5	7.0	0.90	8.2	7.6
940	1.70	6.5	6.1	1.55	7.0	6.6	1.40	7.7	7.2	1.31	8.3	7.8	1.09	9.0	8.4

1. Unit resistance is based on a dry evaporator coil and clean filters.
2. Available static pressure in IWG to overcome the resistance of the duct system and any accessories added to the unit. Refer to the blower motor and drive table and the accessory static resistance table for additional information.
3. Motors can be selected to operate into the service factor because they are located in the moving air stream, upstream of any heating device. units with steam or hot water coils are the only exception. On these units, the BHP must not exceed the nominal HP rating of the motor.

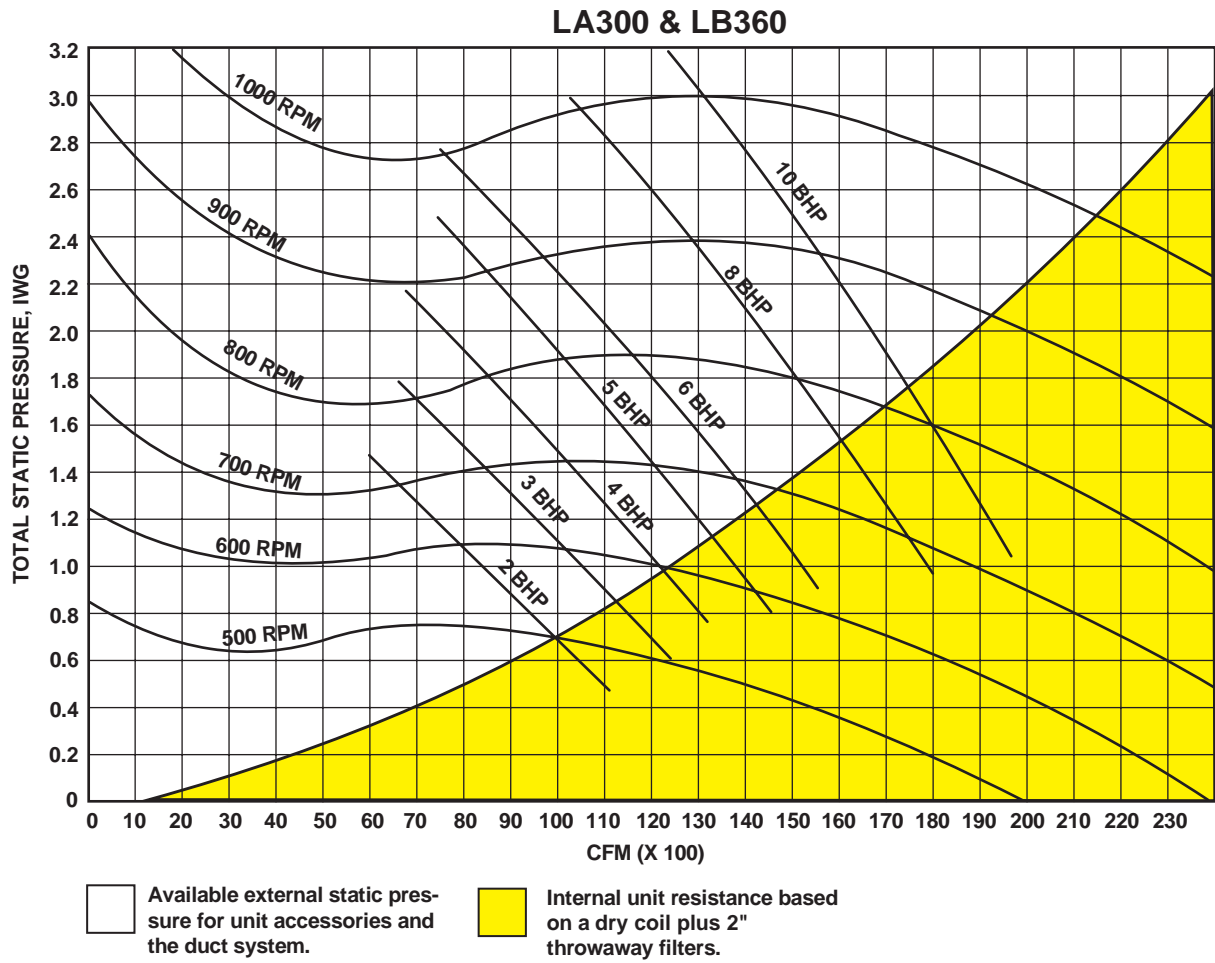

FIGURE 16 - BLOWER CURVE LA300 & LB360

TABLE 21: FAN PERFORMANCE DATA - 40 TON¹

RPM	CFM														
	12,800			14,400			16,000			17,600			19,200		
	SP ²	BHP	κW	SP ²	BHP	κW	SP ²	BHP	κW	SP ²	BHP	κW	SP ²	BHP	κW
600	0.20	4.3	3.7	-	-	-	-	-	-	-	-	-	-	-	-
640	0.38	4.8	4.1	0.19	5.6	4.8	-	-	-	-	-	-	-	-	-
700	0.65	5.5	4.7	0.47	6.4	5.5	0.28	7.2	6.2	-	-	-	-	-	-
775	0.99	6.5	5.6	0.84	7.4	6.4	0.66	8.4	7.2	0.46	9.4	8.1	0.23	10.4	9.0
800	1.11	6.8	5.9	0.96	7.8	6.7	0.79	8.8	7.6	0.59	9.8	8.4	0.36	10.8	9.3
900	1.65	8.1	7.0	1.52	9.3	8.0	1.36	10.5	9.0	-	-	-	-	-	-
915	1.73	8.3	7.2	1.60	9.5	8.2	1.44	10.7	9.2	-	-	-	-	-	-

1. Unit resistance is based on a dry evaporator coil and clean filters.
2. Available static pressure in IWG to overcome the resistance of the duct system and any accessories added to the unit. Refer to the blower motor and drive table and the accessory static resistance table for additional information.

TABLE 22: FAN PERFORMANCE DATA - 50 TON¹

RPM	CFM														
	16,000			18,000			20,000			22,000			24,000		
	SP ²	BHP	κW	SP ²	BHP	κW	SP ²	BHP	κW	SP ²	BHP	κW	SP ²	BHP	κW
600	0.82	6.0	5.2	0.59	7.2	6.2	0.35	8.4	7.2	0.08	9.7	8.4	-	-	-
660	1.17	7.3	6.3	0.96	8.5	7.3	0.73	9.8	8.5	0.45	11.2	9.7	0.14	12.7	11.0
700	1.40	8.2	7.1	1.21	9.4	8.1	0.98	10.7	9.2	0.70	12.2	10.5	0.40	13.7	11.8
760	1.76	9.5	8.2	1.59	10.8	9.3	1.38	12.3	10.6	1.11	13.8	11.9	0.81	15.6	13.5
800	2.00	10.4	9.0	1.85	11.8	10.2	1.64	13.3	11.5	1.38	14.9	12.9	1.09	16.9	14.6
900	2.60	12.8	11.0	2.49	14.5	12.5	2.35	16.0	13.8	-	-	-	-	-	-
930	2.78	13.5	11.6	2.68	15.3	13.2	-	-	-	-	-	-	-	-	-

1. Unit resistance is based on a dry evaporator coil and clean filters.
2. Available static pressure in IWG to overcome the resistance of the duct system and any accessories added to the unit. Refer to the blower motor and drive table and the accessory static resistance table for additional information.

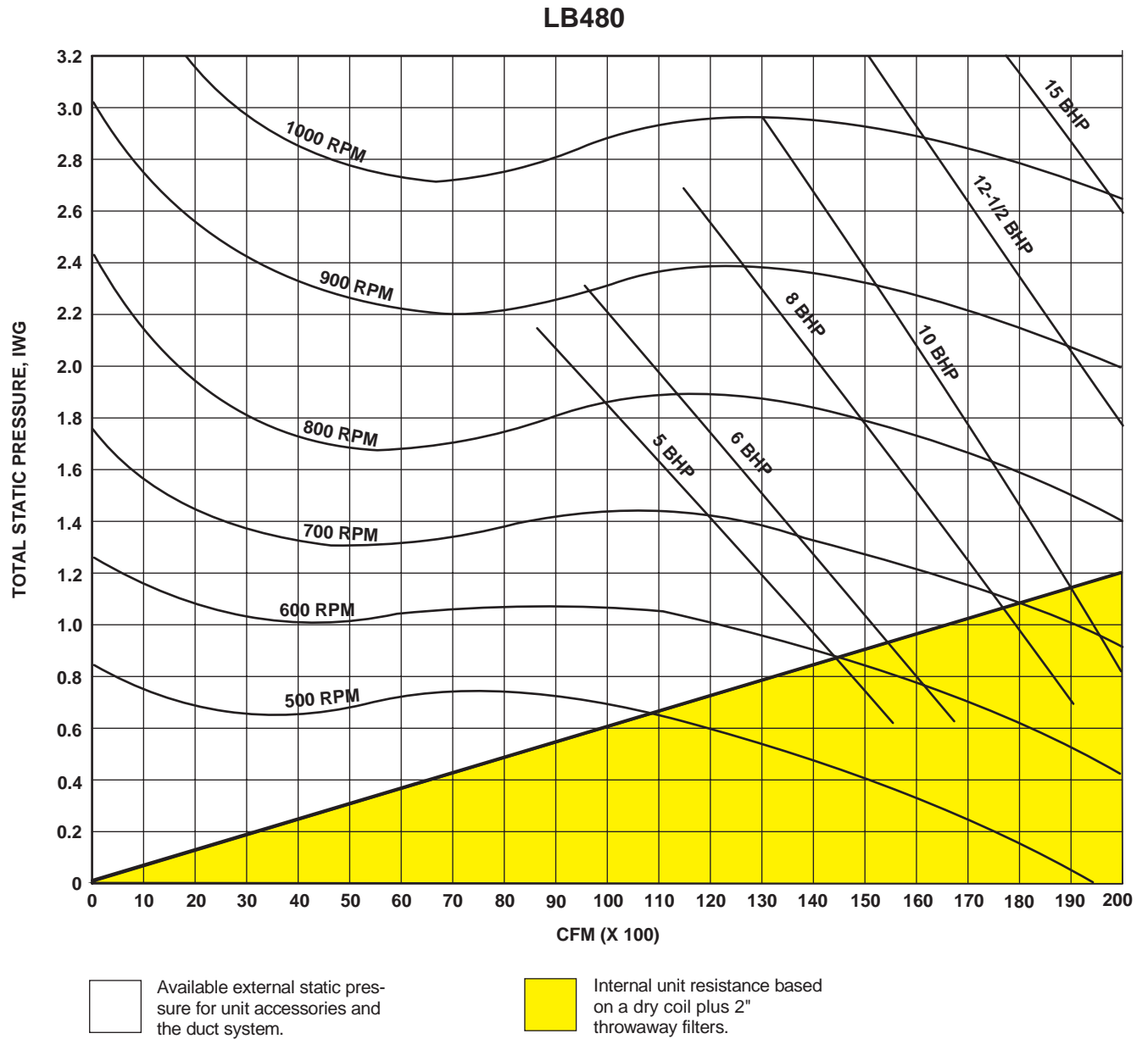

FIGURE 17 - BLOWER CURVE LB480

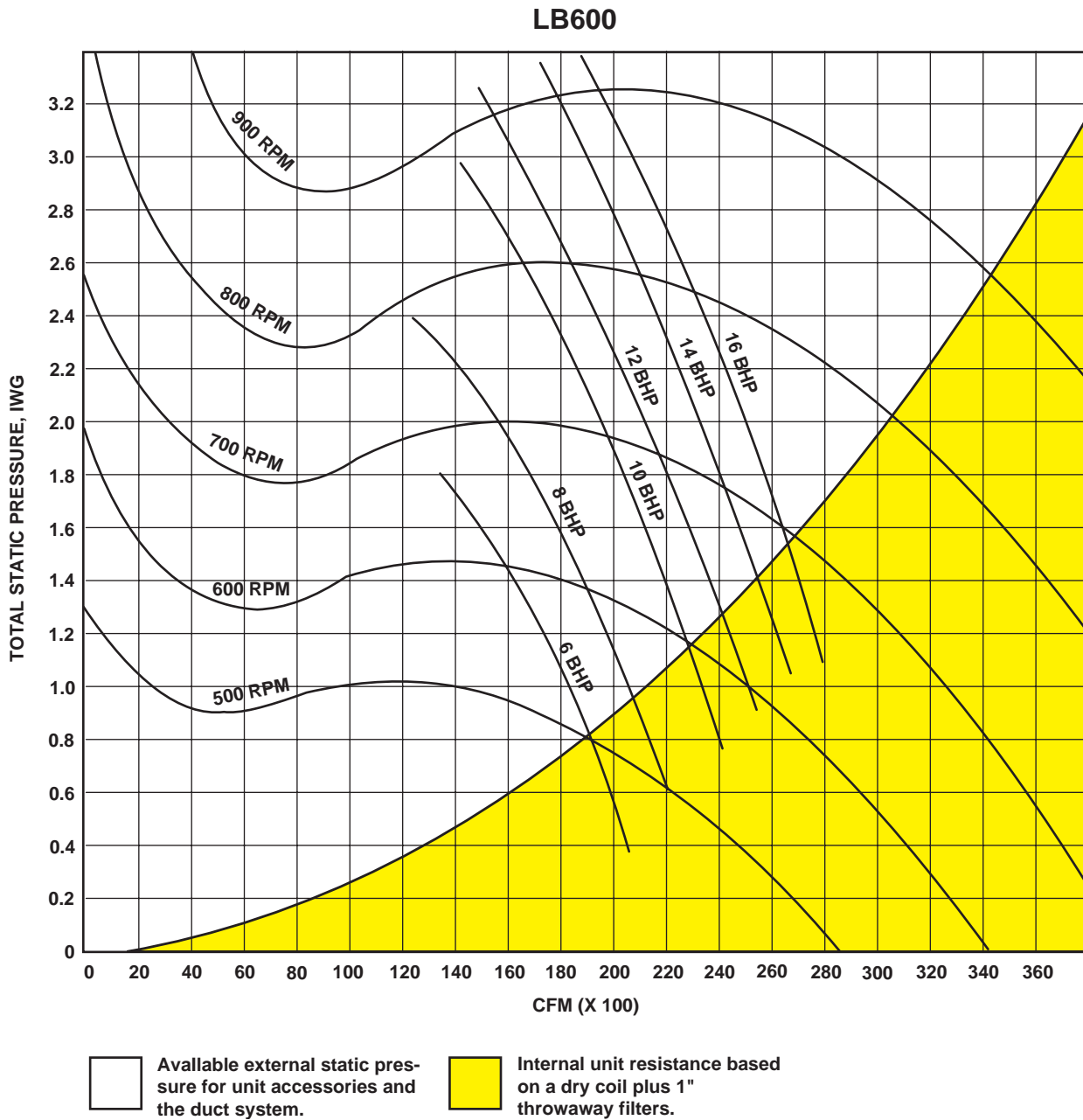

FIGURE 18 - BLOWER CURVE LB600

GUIDE SPECIFICATIONS

EACH UNIT SHALL BE:

- Covered by a 1-year limited parts warranty on the complete unit.
- In current production with published literature available to check performance, limitations, specifications, power requirements, dimensions, operation and appearance; also equipped with a V-belt drive option that:
 - a. Will permit the blower RPM to be adjusted to meet the exact CFM requirement of the system.

EACH UNIT ENCLOSURE SHALL HAVE:

- A steel angle frame to provide the rigid support required for shipping, rigging and years of dependable operation.
- Exterior panels of 18 gauge steel, finished with baked enamel to provide a long lasting quality appearance
- Removable panels to provide easy access to the internal components for maintenance and service, and,
- A filter rack with 2" filters.

THE DIMENSIONS OF EACH UNIT SHALL NOT EXCEED THOSE SPECIFIED.

THE BLOWER MOTOR SHALL:

- Be mounted within the insulated cabinet to minimize the transmission of sound to the surrounding space, and
- Have a service factor of 1.15.

THE EVAPORATOR COIL SHALL:

- Consist of copper tubes arranged in staggered rows, mechanically expanded into aluminum fins,
- Be draw-through, and
- Include factory-mounted distributors, expansion valves and solenoid valves for both capacity reduction and pumpdown.

THE BLOWER WHEELS SHALL:

- Be dynamically balanced to minimize the levels of sound and vibration generated by the unit.

Subject to change without notice. Printed in U.S.A.
Copyright © 2006 by Unitary Products Group. All rights reserved.

036-21335-003-B-0206
Supersedes: 036-21335-003-A-0204

**Unitary
Products
Group**

**5005
York
Drive**

**Norman
OK
73069**